



**CALL NO. 107**

**CONTRACT ID. 204410**

**UNION COUNTY**

**FED/STATE PROJECT NUMBER HSIP 5049(006)**

**DESCRIPTION AIRLINE ROAD (KY 130)**

**WORK TYPE ASPHALT PAVEMENT & ROADWAY REHAB**

**PRIMARY COMPLETION DATE 8/31/2021**

**LETTING DATE: November 20,2020**

Sealed Bids will be received electronically through the Bid Express bidding service until 10:00 am EASTERN STANDARD TIME November 20,2020. Bids will be publicly announced at 10:00 am EASTERN STANDARD TIME.

**NO PLANS ASSOCIATED WITH THIS PROJECT.**

**DBE CERTIFICATION REQUIRED - 16%**

**REQUIRED BID PROPOSAL GUARANTY:** Not less than 5% of the total bid.

## TABLE OF CONTENTS

PART I	SCOPE OF WORK
	<ul style="list-style-type: none"><li>• PROJECT(S), COMPLETION DATE(S), &amp; LIQUIDATED DAMAGES</li><li>• CONTRACT NOTES</li><li>• FEDERAL CONTRACT NOTES</li><li>• ASPHALT MIXTURE</li><li>• DGA BASE</li><li>• FUEL AND ASPHALT PAY ADJUSTMENT</li><li>• COMPACTION OPTION A</li><li>• SPECIAL NOTE(S) APPLICABLE TO PROJECT</li><li>• LIQUIDATED DAMAGES</li><li>• WASTE AND BORROW SITES</li><li>• COORDINATION OF WORK WITH OTHER CONTRACTS</li><li>• DOUBLE ASPHALT SEAL COAT</li><li>• EDGE KEY (BY TON)</li><li>• GUARDRAIL</li><li>• ASPHALT MILLING AND TEXTURING</li><li>• BASE FAILURE REPAIR 23STONE-12IN-PAY SY</li><li>• TYPICAL SECTION DIMENSIONS</li><li>• TRAFFIC CONTROL PLAN</li><li>• DURABLE PAVEMENT EDGE DETAILS</li><li>• RIGHT OF WAY CERTIFICATION</li><li>• UTILITY IMPACT &amp; RAIL CERTIFICATION NOTES</li><li>• KPDES STORM WATER PERMIT, BMP AND ENOI</li><li>• SKETCH MAP(S)</li><li>• SUMMARY SHEET(S)</li><li>• TYPICAL SECTION(S)</li><li>• DETAIL SHEET(S)</li><li>• GUARDRAIL DELIVERY VERIFICATION SHEET</li><li>• BRIDGE DETAIL FOR PAVING PROJECT</li></ul>
PART II	SPECIFICATIONS AND STANDARD DRAWINGS
	<ul style="list-style-type: none"><li>• SPECIFICATIONS REFERENCE</li><li>• SUPPLEMENTAL SPECIFICATION</li><li>• [SN-11M] BARCODE LABEL ON PERMANENT SIGNS</li><li>• 2020 STANDARD DRAWINGS THAT APPLY</li></ul>
PART III	EMPLOYMENT, WAGE AND RECORD REQUIREMENTS
	<ul style="list-style-type: none"><li>• FEDERAL-AID CONSTRUCTION CONTRACTS - FHWA 1273</li><li>• NONDISCRIMINATION OF EMPLOYEES</li><li>• EXECUTIVE BRANCH CODE OF ETHICS</li><li>• PROJECT WAGE RATES LOCALITY 1 / FEDERAL</li><li>• NOTICE OF REQUIREMENT FOR AFFIRMATIVE ACTION TO ENSURE EEO UNION</li></ul>
PART IV	INSURANCE
PART V	BID ITEMS

**PART I**  
**SCOPE OF WORK**

## ADMINISTRATIVE DISTRICT - 02

**CONTRACT ID - 204410**

**HSIP 5049(006)**

**COUNTY - UNION**

**PCN - 0211301302001**

**HSIP 5049(006)**

AIRLINE ROAD (KY 130) (MP 9.584) FROM 0.019 MILE NORTH OF US 60 TO THE INTERSECTION WITH KY 360 (MP 15.657), A DISTANCE OF 06.07 MILES.ASPHALT PAVEMENT & ROADWAY REHAB SYP NO. 02-09009.00.  
GEOGRAPHIC COORDINATES LATITUDE 37:43:42.60 LONGITUDE -87:55:15.50

**COMPLETION DATE(S):**

COMPLETED BY 08/31/2021

APPLIES TO ENTIRE PROJECT

## **CONTRACT NOTES**

### **PROPOSAL ADDENDA**

All addenda to this proposal must be applied when calculating bid and certified in the bid packet submitted to the Kentucky Department of Highways. Failure to use the correct and most recent addenda may result in the bid being rejected.

### **BID SUBMITTAL**

Bidder must use the Department's electronic bidding software. The Bidder must download the bid file located on the Bid Express website ([www.bidx.com](http://www.bidx.com)) to prepare a bid packet for submission to the Department. The bidder must submit electronically using Bid Express.

### **JOINT VENTURE BIDDING**

Joint venture bidding is permissible. All companies in the joint venture must be prequalified in one of the work types in the Qualifications for Bidders for the project. The bidders must get a vendor ID for the joint venture from the Division of Construction Procurement and register the joint venture as a bidder on the project. Also, the joint venture must obtain a digital ID from Bid Express to submit a bid. A joint bid bond of 5% may be submitted for both companies or each company may submit a separate bond of 5%.

### **UNDERGROUND FACILITY DAMAGE PROTECTION**

The contractor shall make every effort to protect underground facilities from damage as prescribed in the Underground Facility Damage Protection Act of 1994, Kentucky Revised Statute KRS 367.4901 to 367.4917. It is the contractor's responsibility to determine and take steps necessary to be in compliance with federal and state damage prevention directives. When prescribed in said directives, the contractor shall submit Excavation Locate Requests to the Kentucky Contact Center (KY811) via web ticket entry. The submission of this request does not relieve the contractor from the responsibility of contacting non-member facility owners, whom shall be contacted through their individual Protection Notification Center. Non-compliance with these directives can result in the enforcement of penalties.

### **REGISTRATION WITH THE SECRETARY OF STATE BY A FOREIGN ENTITY**

Pursuant to KRS 176.085(1)(b), an agency, department, office, or political subdivision of the Commonwealth of Kentucky shall not award a state contract to a person that is a foreign entity required by [KRS 14A.9-010](#) to obtain a certificate of authority to transact business in the Commonwealth ("certificate") from the Secretary of State under [KRS 14A.9-030](#) unless the person produces the certificate within fourteen (14) days of the bid or proposal opening. If the foreign entity is not required to obtain a certificate as provided in [KRS 14A.9-010](#), the foreign entity should identify the applicable exception. Foreign entity is defined within [KRS 14A.1-070](#).

**For all foreign entities required to obtain a certificate of authority to transact business in the Commonwealth, if a copy of the certificate is not received by the contracting agency within the time frame identified above, the foreign entity's solicitation response shall be deemed non-responsive or the awarded contract shall be cancelled.**

Businesses can register with the Secretary of State at <https://secure.kentucky.gov/sos/ftbr/welcome.aspx>.

#### **SPECIAL NOTE FOR PROJECT QUESTIONS DURING ADVERTISEMENT**

Questions about projects during the advertisement should be submitted in writing to the Division of Construction Procurement. This may be done by fax (502) 564-7299 or email to [kytc.projectquestions@ky.gov](mailto:kytc.projectquestions@ky.gov). The Department will attempt to answer all submitted questions. The Department reserves the right not to answer if the question is not pertinent or does not aid in clarifying the project intent.

The deadline for posting answers will be 3:00 pm Eastern Daylight Time, the day preceding the Letting. Questions may be submitted until this deadline with the understanding that the later a question is submitted, the less likely an answer will be able to be provided.

The questions and answers will be posted for each Letting under the heading "Questions & Answers" on the Construction Procurement website ([www.transportation.ky.gov/contract](http://www.transportation.ky.gov/contract)). The answers provided shall be considered part of this Special Note and, in case of a discrepancy, will govern over all other bidding documents.

#### **HARDWOOD REMOVAL RESTRICTIONS**

The US Department of Agriculture has imposed a quarantine in Kentucky and several surrounding states, to prevent the spread of an invasive insect, the emerald ash borer. Hardwood cut in conjunction with the project may not be removed from the state. Chipping or burning on site is the preferred method of disposal.

#### **INSTRUCTIONS FOR EXCESS MATERIAL SITES AND BORROW SITES**

Identification of excess material sites and borrow sites shall be the responsibility of the Contractor. The Contractor shall be responsible for compliance with all applicable state and federal laws and may wish to consult with the US Fish and Wildlife Service to seek protection under Section 10 of the Endangered Species Act for these activities.

#### **ACCESS TO RECORDS**

The contractor, as defined in KRS 45A.030 (9) agrees that the contracting agency, the Finance and Administration Cabinet, the Auditor of Public Accounts, and the Legislative Research Commission, or their duly authorized representatives, shall have access to any books, documents, papers, records, or other evidence, which are directly pertinent to this contract for the purpose of financial audit or program review. Records and other prequalification information confidentially

disclosed as part of the bid process shall not be deemed as directly pertinent to the contract and shall be exempt from disclosure as provided in KRS 61.878(1)(c). The contractor also recognizes that any books, documents, papers, records, or other evidence, received during a financial audit or program review shall be subject to the Kentucky Open Records Act, KRS 61.870 to 61.884.

In the event of a dispute between the contractor and the contracting agency, Attorney General, or the Auditor of Public Accounts over documents that are eligible for production and review, the Finance and Administration Cabinet shall review the dispute and issue a determination, in accordance with Secretary's Order 11-004.

April 30, 2018

### **FEDERAL CONTRACT NOTES**

The Kentucky Department of Highways, in accordance with the Regulations of the United States Department of Transportation 23 CFR 635.112 (h), hereby notifies all bidders that failure by a bidder to comply with all applicable sections of the current Kentucky Standard Specifications, including, but not limited to the following, may result in a bid not being considered responsive and thus not eligible to be considered for award:

- |                                |  |
|--------------------------------|--|
| 102.02 Current Rating          | 102.08 Preparation and Delivery of Proposals |
| 102.13 Irregular Bid Proposals | 102.14 Disqualification of Bidders           |
| 102.09 Proposal Guaranty       |  |

### **CIVIL RIGHTS ACT OF 1964**

The Kentucky Department of Highways, in accordance with the provisions of Title VI of the Civil Rights Act of 1964 (78 Stat. 252) and the Regulations of the Federal Department of Transportation (49 C.F.R., Part 21), issued pursuant to such Act, hereby notifies all bidders that it will affirmatively insure that the contract entered into pursuant to this advertisement will be awarded to the lowest responsible bidder without discrimination on the ground of race, color, or national origin.

### **NOTICE TO ALL BIDDERS**

To report bid rigging activities call: 1-800-424-9071.

The U.S. Department of Transportation (DOT) operates the above toll-free "hotline" Monday through Friday, 8:00 a.m. to 5:00 p.m. eastern time. Anyone with knowledge of possible bid rigging, bidder collusion, or other fraudulent activities should use the "hotline" to report such activities.

The "hotline" is part of the DOT's continuing effort to identify and investigate highway construction contract fraud and abuse and is operated under the direction of the DOT Inspector General. All information will be treated confidentially and caller anonymity will be respected.

### **SECOND TIER SUBCONTRACTS**

Second Tier subcontracts on federally assisted projects shall be permitted. However, in the case of DBE's, second tier subcontracts will only be permitted where the other subcontractor is also a DBE. All second tier subcontracts shall have the consent of both the Contractor and the Engineer.

### **DISADVANTAGED BUSINESS ENTERPRISE PROGRAM**

It is the policy of the Kentucky Transportation Cabinet (“the Cabinet”) that Disadvantaged Business Enterprises (“DBE”) shall have the opportunity to participate in the performance of highway construction projects financed in whole or in part by Federal Funds in order to create a level playing field for all businesses who wish to contract with the Cabinet. To that end, the Cabinet will comply with the regulations found in 49 CFR Part 26, and the definitions and requirements contained therein shall be adopted as if set out verbatim herein.

The Cabinet, contractors, subcontractors, and sub-recipients shall not discriminate on the basis of race, color, national origin, or sex in the performance of work performed pursuant to Cabinet contracts. The contractor shall carry out applicable requirements of 49 CFR 26 in the award and administration of federally assisted highway construction projects. The contractor will include this provision in all its subcontracts and supply agreements pertaining to contracts with the Cabinet.

Failure by the contractor to carry out these requirements is a material breach of its contract with the Cabinet, which may result in the termination of the contract or such other remedy as the Cabinet deems necessary.

### **DBE GOAL**

The Disadvantaged Business Enterprise (DBE) goal established for this contract, as listed on the front page of the proposal, is the percentage of the total value of the contract.

The contractor shall exercise all necessary and reasonable steps to ensure that Disadvantaged Business Enterprises participate in a least the percent of the contract as set forth above as goals for this contract.

### **OBLIGATION OF CONTRACTORS**

Each contractor prequalified to perform work on Cabinet projects shall designate and make known to the Cabinet a liaison officer who is assigned the responsibility of effectively administering and promoting an active program for utilization of DBEs.

If a formal goal has not been designated for the contract, all contractors are encouraged to consider DBEs for subcontract work as well as for the supply of material and services needed to perform this work.

Contractors are encouraged to use the services of banks owned and controlled by minorities and women.

### **CERTIFICATION OF CONTRACT GOAL**

Contractors shall include the following certification in bids for projects for which a DBE goal has been established. BIDS SUBMITTED WHICH DO NOT INCLUDE CERTIFICATION OF DBE PARTICIPATION WILL NOT BE ACCEPTED. These bids will not be considered for award by the Cabinet and they will be returned to the bidder.

“The bidder certifies that it has secured participation by Disadvantaged Business Enterprises (“DBE”) in the amount of \_\_\_\_\_ percent of the total value of this contract and that the DBE participation is in compliance with the requirements of 49 CFR 26 and the policies of the Kentucky Transportation Cabinet pertaining to the DBE Program.”

**The certification statement is located in the electronic bid file. All contractors must certify their DBE participation on that page. DBEs utilized in achieving the DBE goal must be certified and prequalified for the work items at the time the bid is submitted.**

### **DBE PARTICIPATION PLAN**

Lowest responsive bidders must submit the *DBE Plan/ Subcontractor Request*, form TC 14-35 DBE, within **5** days of the letting. This is necessary before the Awards Committee will review and make a recommendation. **The project will not be considered for award prior to submission and approval of the apparent low bidder’s DBE Plan/Subcontractor Request.**

The DBE Participation Plan shall include the following:

1. Name and address of DBE Subcontractor(s) and/or supplier(s) intended to be used in the proposed project;
2. Description of the work each is to perform including the work item, unit, quantity, unit price and total amount of the work to be performed by the individual DBE. The Proposal Line Number, Category Number, and the Project Line Number can be found in the “material listing” on the Construction Procurement website under the specific letting;
3. The dollar value of each proposed DBE subcontract and the percentage of total project contract value this represents. DBE participation may be counted as follows:
  - a. If DBE suppliers and manufactures assume actual and contractual responsibility, the dollar value of materials to be furnished will be counted toward the goal as follows:
    - The entire expenditure paid to a DBE manufacturer;
    - 60 percent of expenditures to DBE suppliers that are not manufacturers provided the supplier is a regular dealer in the product involved. A regular dealer must be engaged in, as its principal business and in its own name, the sale of products to the public, maintain an inventory and own and operate distribution equipment; and
    - The amount of fees or commissions charged by the DBE firms for a bona fide service, such as professional, technical, consultant, or managerial services and assistance in the procurement of essential personnel, facilities, equipment, materials, supplies, delivery of materials and supplies or for furnishing bonds, or insurance, providing such fees or commissions are determined to be reasonable and customary.

- b) The dollar value of services provided by DBEs such as quality control testing, equipment repair and maintenance, engineering, staking, etc.;
  - c) The dollar value of joint ventures. DBE credit for joint ventures will be limited to the dollar amount of the work actually performed by the DBE in the joint venture;
4. Written and signed documentation of the bidder's commitment to use a DBE contractor whose participation is being utilized to meet the DBE goal; and
  5. Written and signed confirmation from the DBE that it is participating in the contract as provided in the prime contractor's commitment.

#### **UPON AWARD AND BEFORE A WORK ORDER WILL BE ISSUED**

Contractors must submit the signed subcontract between the contractor and the DBE contractor, along with the DBE's certificate of insurance. If the DBE is a supplier of materials for the project, a signed purchase order must be submitted to the Division of Construction Procurement.

Changes to DBE Participation Plans must be approved by the Cabinet. The Cabinet may consider extenuating circumstances including, but not limited to, changes in the nature or scope of the project, the inability or unwillingness of a DBE to perform the work in accordance with the bid, and/or other circumstances beyond the control of the prime contractor.

#### **CONSIDERATION OF GOOD FAITH EFFORTS REQUESTS**

If the DBE participation submitted in the bid by the apparent lowest responsive bidder does not meet or exceed the DBE contract goal, the apparent lowest responsive bidder must submit a Good Faith Effort Package to satisfy the Cabinet that sufficient good faith efforts were made to meet the contract goals prior to submission of the bid. Efforts to increase the goal after bid submission will not be considered in justifying the good faith effort, unless the contractor can show that the proposed DBE was solicited prior to the letting date. DBEs utilized in achieving the DBE goal must be certified and prequalified for the work items at the time the bid is submitted. One complete set (hard copy along with an electronic copy) of this information must be received in the Division of Contract Procurement no later than 12:00 noon of the tenth calendar day after receipt of notification that they are the apparent low bidder.

Where the information submitted includes repetitious solicitation letters it will be acceptable to submit a sample representative letter along with a distribution list of the firms solicited. Documentation of DBE quotations shall be a part of the good faith effort submittal as necessary to demonstrate compliance with the factors listed below which the Cabinet considers in judging good faith efforts. This documentation may include written subcontractors' quotations, telephone log notations of verbal quotations, or other types of quotation documentation.

The Good Faith Effort Package shall include, but may not be limited to information showing evidence of the following:

1. Whether the bidder attended any pre-bid meetings that were scheduled by the Cabinet to inform DBEs of subcontracting opportunities;
2. Whether the bidder provided solicitations through all reasonable and available means;
3. Whether the bidder provided written notice to all DBEs listed in the DBE directory at the time of the letting who are prequalified in the areas of work that the bidder will be subcontracting;
4. Whether the bidder followed up initial solicitations of interest by contacting DBEs to determine with certainty whether they were interested. If a reasonable amount of DBEs within the targeted districts do not provide an intent to quote or no DBEs are prequalified in the subcontracted areas, the bidder must notify the Disadvantaged Enterprise Business Liaison Officer (DEBLO) in the Office of Civil Rights and Small Business Development to give notification of the bidder's inability to get DBE quotes;
5. Whether the bidder selected portions of the work to be performed by DBEs in order to increase the likelihood of meeting the contract goals. This includes, where appropriate, breaking out contract work items into economically feasible units to facilitate DBE participation, even when the prime contractor might otherwise perform these work items with its own forces;
6. Whether the bidder provided interested DBEs with adequate and timely information about the plans, specifications, and requirements of the contract;
7. Whether the bidder negotiated in good faith with interested DBEs not rejecting them as unqualified without sound reasons based on a thorough investigation of their capabilities. Any rejection should be so noted in writing with a description as to why an agreement could not be reached;
8. Whether quotations were received from interested DBE firms but were rejected as unacceptable without sound reasons why the quotations were considered unacceptable. The fact that the DBE firm's quotation for the work is not the lowest quotation received will not in itself be considered as a sound reason for rejecting the quotation as unacceptable. The fact that the bidder has the ability and/or desire to perform the contract work with its own forces will not be considered a sound reason for rejecting a DBE quote. Nothing in this provision shall be construed to require the bidder to accept unreasonable quotes in order to satisfy DBE goals;
9. Whether the bidder specifically negotiated with subcontractors to assume part of the responsibility to meet the contract DBE goal when the work to be subcontracted includes potential DBE participation;
10. Whether the bidder made any efforts and/or offered assistance to interested DBEs in obtaining the necessary equipment, supplies, materials, insurance and/or bonding to satisfy the work requirements of the bid proposal; and
11. Any other evidence that the bidder submits which may show that the bidder has made reasonable good faith efforts to include DBE participation.

### **FAILURE TO MEET GOOD FAITH REQUIREMENT**

Where the apparent lowest responsive bidder fails to submit sufficient participation by DBE firms to meet the contract goal and upon a determination by the Good Faith Committee based upon the information submitted that the apparent lowest responsive bidder failed to make sufficient reasonable efforts to meet the contract goal, the bidder will be offered the opportunity to meet in person for administrative reconsideration. The bidder will be notified of the Committee's decision within 24 hours of its decision. The bidder will have 24 hours to request reconsideration of the Committee's decision. The reconsideration meeting will be held within two days of the receipt of a request by the bidder for reconsideration.

The request for reconsideration will be heard by the Office of the Secretary. The bidder will have the opportunity to present written documentation or argument concerning the issue of whether it met the goal or made an adequate good faith effort. The bidder will receive a written decision on the reconsideration explaining the basis for the finding that the bidder did or did not meet the goal or made adequate Good Faith efforts to do so.

The result of the reconsideration process is not administratively appealable to the Cabinet or to the United States Department of Transportation.

The Cabinet reserves the right to award the contract to the next lowest responsive bidder or to rebid the contract in the event that the contract is not awarded to the low bidder as the result of a failure to meet the good faith requirement.

### **SANCTIONS FOR FAILURE TO MEET DBE REQUIREMENTS OF THE PROJECT**

Failure by the prime contractor to fulfill the DBE requirements of a project under contract or to demonstrate good faith efforts to meet the goal constitutes a breach of contract. When this occurs, the Cabinet will hold the prime contractor accountable, as would be the case with all other contract provisions. Therefore, the contractor's failure to carry out the DBE contract requirements shall constitute a breach of contract and as such the Cabinet reserves the right to exercise all administrative remedies at its disposal including, but not limited to the following:

- Disallow credit toward the DBE goal;
- Withholding progress payments;
- Withholding payment to the prime in an amount equal to the unmet portion of the contract goal; and/or
- Termination of the contract.

### **PROMPT PAYMENT**

The prime contractor will be required to pay the DBE within seven (7) working days after he or she has received payment from the Kentucky Transportation Cabinet for work performed or materials furnished.

### **CONTRACTOR REPORTING**

All contractors must keep detailed records and provide reports to the Cabinet on their progress in meeting the DBE requirement on any highway contract. These records may include, but shall not be limited to payroll, lease agreements, cancelled payroll checks, executed subcontracting agreements, etc. Prime contractors will be required to complete and submit a **signed and notarized** Affidavit of Subcontractor Payment (TC 18-7) and copies of checks for any monies paid to each DBE subcontractor or supplier utilized to meet a DBE goal. These documents must be completed and signed within 7 days of being paid by the Cabinet.

Payment information that needs to be reported includes date the payment is sent to the DBE, check number, Contract ID, amount of payment and the check date. Before Final Payment is made on this contract, the Prime Contractor will certify that all payments were made to the DBE subcontractor and/or DBE suppliers.

**\*\*\*\*\* IMPORTANT \*\*\*\*\***

**Please mail the original, signed and completed TC (18-7) Affidavit of Subcontractor Payment form and all copies of checks for payments listed above to the following address:**

Office of Civil Rights and Small Business Development  
6<sup>th</sup> Floor West 200 Mero Street  
Frankfort, KY 40622

The prime contractor should notify the KYTC Office of Civil Rights and Small Business Development seven (7) days prior to DBE contractors commencing work on the project. The contact in this office is Mr. Melvin Bynes. Mr. Bynes' current contact information is email address – [melvin.bynes2@ky.gov](mailto:melvin.bynes2@ky.gov) and the telephone number is (502) 564-3601.

### **DEFAULT OR DECERTIFICATION OF THE DBE**

If the DBE subcontractor or supplier is decertified or defaults in the performance of its work, and the overall goal cannot be credited for the uncompleted work, the prime contractor may utilize a substitute DBE or elect to fulfill the DBE goal with another DBE on a different work item. If after exerting good faith effort in accordance with the Cabinet's Good Faith Effort policies and procedures, the prime contractor is unable to replace the DBE, then the unmet portion of the goal may be waived at the discretion of the Cabinet.

### **PROHIBITION ON TELECOMMUNICATIONS EQUIPMENT OR SERVICES**

In accordance with the FY 2019 National Defense Authorization Act (NDAA), 2 CFR 200.216, and 2 CFR 200.471, Federal agencies are prohibited, after August 13, 2020, from obligating or expending financial assistance to obtain certain telecommunications and video surveillance services and equipment from specific producers. As a result of these regulations, contractors and subcontractors are prohibited, on projects with federal funding participation, from providing telecommunication or video surveillance equipment, services, or systems produced by:

- Huawei Technologies Company or ZTE Corporation (or any subsidiary or affiliate of such entities)
- Hytera Communications Corporation, Hangzhou Hikvision Digital Technology Company, or Dahua Technology Company (or any subsidiary or affiliate of such entities)

**LEGAL REQUIREMENTS AND RESPONSIBILITY TO THE PUBLIC – CARGO PREFERENCE ACT (CPA).**

**(REV 12-17-15) (1-16)**

SECTION 7 is expanded by the following new Article:

102.10 **Cargo Preference Act – Use of United States-flag vessels.**

Pursuant to Title 46CFR Part 381, the Contractor agrees

- To utilize privately owned United States-flag commercial vessels to ship at least 50 percent of the gross tonnage (computed separately for dry bulk carriers, dry cargo liners, and tankers) involved, whenever shipping any equipment, material, or commodities pursuant to this contract, to the extent such vessels are available at fair and reasonable rates for United States-flag commercial vessels.

- To furnish within 20 days following the date of loading for shipments originating within the United States or within 30 working days following the date of loading for shipments originating outside the United States, a legible copy of a rated, 'on-board' commercial ocean bill-of-lading in English for each shipment of cargo described in paragraph 1 of this section to both the Contracting Officer (through the prime contractor in the case of subcontractor bills-of-lading) and to the Division of National Cargo, Office of Market Development, Maritime Administration, Washington, DC 20590.

- To insert the substance of the provisions of this clause in all subcontracts issued pursuant to this contract.

**ASPHALT MIXTURE**

Unless otherwise noted, the Department estimates the rate of application for all asphalt mixtures to be 110 lbs/sy per inch of depth.

**DGA BASE**

Unless otherwise noted, the Department estimates the rate of application for DGA Base to be 115 lbs/sy per inch of depth.

**FUEL AND ASPHALT PAY ADJUSTMENT**

The Department has included the Contract items Asphalt Adjustment and Fuel Adjustment for possible future payments at an established Contract unit price of \$1.00. The Department will calculate actual adjustment quantities after work is completed. If existing Contract amount is insufficient to pay all items on the contract with the adjustments, the Department will establish additional monies with a change order.

**OPTION A**

Be advised that the Department will accept compaction of asphalt mixtures furnished for driving lanes and ramps, at 1 inch (25mm) or greater, on this project according to OPTION A in accordance with Section 402 and Section 403 of the current Standard Specifications. The Department will require joint cores as described in Section 402.03.02 for surface mixtures only. The Department will accept compaction of all other asphalt mixtures according to OPTION B.

## **Special Notes Applicable to Project – General Notes & Description of Work**

---

### **CAUTION**

The information in this proposal and the type of work listed herein are approximate only and are not to be taken as an exact evaluation of the materials and conditions to be encountered during construction; the bidder must draw his/her own conclusions when developing the Unit Bid Prices for each bid item. As such, if the conditions encountered are not in accordance with the information shown, the Department does not guarantee any changes to the Unit Bid Prices nor extension of the contract will be considered. The Department will pay for bid item quantity overruns, but only if pre-approved by the Engineer.

### **STATIONING**

The Contractor is advised that the planned locations of work were established from a beginning station number which is STA 506+04 at Milepoint 9.584 (the asphalt pavement joint in the northern leg of the intersection of KY 130 and US 60). The existing mile marker signs may not correspond to the proposed work locations.

### **LIDAR**

All survey information was obtained from available KYTC Aerial LIDAR data and should be field verified as appropriate during construction and prior to incorporating the various project work items. Refer to the Special Note for Staking concerning staking operations required to control and construct the work.

### **ON-SITE INSPECTION**

Before submitting a bid for the work, make a thorough inspection of the site and determine existing conditions so that the work can be expeditiously performed after a contract is awarded. The Department will consider submission of a bid to be evidence of this inspection having been made. The Department will not honor any claims for money or time extension resulting from site conditions.

### **RIGHT OF WAY LIMITS**

The Department has not established the exact limits of the Right-of-Way. Unless a consent and release form is obtained from the adjoining property owner, limit work activities to the obvious Right-of-Way and staging areas secured by the Contractor at no additional cost to the Department. In the event that private improvements (i.e. fences, buildings, etc.) encroach upon the Right-of-Way, the Contractor shall notify the Engineer and limit work activities in order to NOT disturb the improvements. If they become necessary, the Department will secure consent and releases from property owners through the Engineer. Be responsible for all encroachments onto private lands.

### **CONTROL**

Perform all work under the absolute control of the Department of Highways. Obtain the Engineer's approval of all designs required to be furnished by the Contractor prior to incorporation into the work. The Department reserves the right to have other work performed by other contractors and its own forces and to permit public utility companies and others to do work during the construction within the limits of, or adjacent to, the project. Conduct operations and cooperate with such other parties so that interference with such other work will be reduced to a minimum. The Department will not honor any claims for money or time extension created by the operations of such other parties. Should a difference of opinion arise as to the rights of the Contractor and others working within the limits of, or adjacent to, the project, the Engineer will decide as to the respective rights of the various parties involved in order to assure the completion of the Department's work in general harmony and in a satisfactory manner, and his/her decision shall be final and binding upon the Contractor.

General Notes & Description of Work  
Page 2 of 5

**DESCRIPTION OF WORK**

Except as specified herein, perform all work in accordance with the Department's Standard Specifications, Supplemental Specifications, applicable Special Notes and Special Provisions, and applicable Standard and Sepia Drawings, current editions. Furnish all materials, labor, equipment, and incidentals for the following work:

**Resurfacing.** Between MP 9.584 (the asphalt pavement joint in the northern KY 130 approach to US 60) and MP 15.657 (the intersection with KY 360) a 1.00" layer of Asphalt Surface is to be constructed. The majority of the corridor is specified to be resurfaced with the CL2 ASPH SURF 0.38D PG64-22 mix while an area that also includes Superelevation Improvements is to receive a 1.5" layer of polish-resistant CL2 ASPH SURF 0.5B PG64-22 mix. Refer to the Resurfacing Summary for location information and application details.

**Base Failure Repair.** A quantity of Base Failure Repair has been included in the Base Failure Repair Summary for use at the locations indicated. Refer to the Special Note for Base Failure Repair for more information.

**Superelevation Improvements.** There are multiple curves where Superelevation Improvements are being proposed. The intent of this work is to provide a consistent pavement cross slope through the identified curves. Refer to the Superelevation Improvement Summary for locations and approximate quantities. The Contractor will utilize Leveling & Wedging to achieve the desired superelevation improvements at the identified locations. The Leveling & Wedging mix design will be based on the lift thickness being constructed in each curve. The Superelevation Improvement Summary lists the estimated quantities of Leveling & Wedging for each curve; however, the Engineer will make the final determination as to which bid items will be required at each superelevation improvement area, as well as the appropriate lift thicknesses and number of lifts based on the existing conditions encountered at the time of construction. As a result of the superelevation improvements, the roadside shoulders, fill slopes, and/or ditches will have to be modified to match the final paved surface elevations and tie in with the existing ground lines. The bid item 'Ditching & Shouldering' has been included for these roadside modifications. Refer to the detail sheet titled: DITCHING & SHOULDERING AND EMBANKMENT BENCHING DETAILS for more information.

NOTE: Some field adjustments of the proposed shoulder width, fill slope, ditch, and/or superelevation improvement may be required. The proposed shoulder and fill slope grading is intended to occur within Right-of-Way and NOT disturb any sensitive obstructions (i.e. fences, buildings, utility poles, etc.). Superelevation improvements with sensitive obstructions along the roadside shall still require the roadside shoulder and fill slope to be modified, but the slope may have to be constructed steeper than what is shown on the Superelevation Improvement Detail. The desire of the Department is to construct the new fill slopes at 3:1 or flatter. When a fill slope needs to be constructed steeper than 3:1 to remain within Right-of-Way or not impact a sensitive obstruction, and the existing fill slope is steeper than 3:1, then the new fill slope can be constructed steeper than 3:1, but the new fill slope shall not be constructed steeper than the existing fill slope. If a desired superelevation improvement will result in the new fill slope having to be graded steeper than the existing fill slope in order to remain within Right-of-Way or not impact a sensitive obstruction, then the superelevation rate should be modified (reduced) in order to reduce the final change in pavement edge elevation, thereby reducing the height of the new fill slope grading, and allowing for a flatter fill slope.

## General Notes & Description of Work

Page 3 of 5

**Widening of Paved Shoulder.** Areas have been identified along the route for widening the paved shoulder. Work will include milling/trenching three feet in width from the existing edgeline. This includes milling four inches in depth within existing asphalt pavement and eight inches in depth outside the existing asphalt pavement. Also included will be placing and compacting DGA Base and Asphalt Base, and regrading the roadside, as shown on the Shoulder Widening Detail and Superelevation Improvement Detail. Perform this work at the locations identified in the Proposal, or the locations as directed by the Engineer. Refer to the Special Note for Shoulder Milling/Trenching for more information.

**Ditching & Shouldering.** Several areas throughout the project are set up for Ditching & Shouldering. Perform Ditching & Shouldering at the locations identified in the Proposal, or the locations as directed by the Engineer. The proposed shoulder, ditch, and/or roadside dimensions are detailed on the Shoulder Widening Detail and Superelevation Improvement Detail. Perform Ditching & Shouldering according to the Special Note for Ditching & Shouldering. For details of the conditions and situations commonly encountered when performing Ditching & Shouldering, refer to the detail sheets titled: DITCHING & SHOULDERING AND EMBANKMENT BENCHING DETAILS.

**DGA Wedge & Chip Seal.** Some sections of "Ditching & Shouldering" are set up to receive a 4" thick DGA Wedge & Chip Seal after the Ditching & Shouldering operations are complete. Other areas of "Ditching & Shouldering" are NOT to receive the DGA Wedge & Chip Seal. See the Ditching & Shouldering Summary for the approximate locations to receive the DGA Wedge & Chip Seal. Generally, the areas that are NOT routinely mowed are the areas to receive the DGA Wedge & Chip Seal. Areas that are routinely mowed by the adjoining property owner have NOT been set up for the DGA Wedge & Chip Seal. Unless otherwise directed by the Engineer, DO NOT place any DGA Wedge & Chip Seal where it appears the adjoining property owner is routinely mowing up to the edge of pavement. The Engineer will determine the exact limits of the DGA Wedge & Chip Seal at the time of construction. Refer to the Special Note for Ditching & Shouldering and the Special Note for Double Asphalt Seal Coat for more information.

**Entrance Pipe Replacement & Driveway Surfacing.** Due to areas of existing ditch line being re-shaped and relocated further from the edge of pavement, there are areas throughout the project where the existing entrance pipe will have to be removed and relocated to line up with the new ditch line. See the Entrance Pipe Summary for the locations and bid items/quantities associated with the entrance pipe replacements. The existing driveway surface is noted on the summary sheet and is to be replaced with in-kind surfacing. The Engineer will make the final determination as to the locations and quantities required to complete the work based on the existing conditions encountered during construction. Refer to the Special Note for Pipe Replacements / Extensions for more information on this item of work.

**Pipe Replacements & Extensions.** There are locations throughout the project where culvert pipes are being replaced and/or extended. Locations are noted on the Pipe Replacement & Extension Summary. Other items that may be associated with the pipe replacements and/or extensions include: Sloped & Mitered Concrete Headwalls, Pipe Culvert Headwalls, Intermediate Anchor/Collar, Ditching & Shouldering, Channel Lining, Erosion Control Blanket, etc. Refer to the Special Note for Pipe Replacements / Extensions for more information on this item of work.

**Sloped & Mitered Concrete Headwalls.** Sloped & Mitered Concrete Headwalls shall be constructed as shown on the detail sheets titled: SLOPED & MITERED CONCRETE HEADWALL DETAILS. This headwall is

## General Notes &amp; Description of Work

Page 4 of 5

intended to combine the benefits of a pipe headwall with the advantages of safety and adaptability by allowing the headwall to be custom fit with the surrounding embankment. The Pipe Replacement & Extension Summary identifies which pipe ends are to receive the Sloped & Mitered Concrete Headwalls. The identified pipe ends shall have the headwall installed at an angle that matches the final embankment slopes at each location. If the pipe is on a skew, install the headwall and miter the pipe so that the concrete slope paving of the new headwall is perpendicular to the roadway. In other words, the headwall should be installed and the pipe should be mitered to match the final embankment slope, so that the roadside fill slope is fairly consistent prior to the pipe, at the pipe, and beyond the pipe. When completed, the edges of the Sloped & Mitered Concrete Headwall should be flush with the surrounding ground line. Payment at the contract unit price per Each shall be full compensation for furnishing all labor, materials, equipment, and incidentals necessary to install the headwall and miter the pipe.

NOTE: For pipes that receive the Sloped & Mitered Concrete Headwall, the pipe length will be measured to the furthest point along the mitered end of the pipe.

**Intermediate Anchor/Collar.** There are quantities of Class A Concrete included in the contract to construct an intermediate anchor, or collar, around the pipes at the pipe extension locations. This is so the new, in-kind pipe can be securely connected to the existing pipe. The intermediate anchors shall be constructed as shown on Standard Drawing RDX-060, current edition.

**Channel Lining.** A quantity of Channel Lining Class II has been included in the Ditching & Shouldering Summary for use at the locations indicated on the Ditching & Shouldering Summary. An additional quantity of Channel Lining Class II has been included on the Pipe Replacement & Extension Summary for use at one pipe inlet and one pipe outlet. The Contractor and Engineer should work together to determine the location and best use of Channel Lining throughout this project. The Engineer will make the final determination as to the needed quantities and placement of Channel Lining.

**Erosion Control Blanket.** A quantity of Erosion Control Blanket has been included in the contract for potential use along areas of regraded shoulders, ditch lines, fill and/or back slopes, inlets and outlets of pipes, and any other areas as directed by the Engineer. The Contractor and Engineer should work together to determine the location and best use of Erosion Control Blanket throughout this project. The Engineer will make the final determination as to the quantities and placement of Erosion Control Blanket.

**Guardrail.** There are locations throughout the project where new guardrail is to be installed, existing guardrail is to be removed and replaced, and existing End Treatments are to be removed and replaced. Refer to the Guardrail Summary for the approximate locations for guardrail replacement. See the Special Note for Guardrail for more information on this work.

NOTE: The Department is experimenting with a new guardrail delineation product. The Contractor is to utilize Luciol Systems Advanced Delineation (<http://www.luciolsystems.com/products.html>) to satisfy this experimental application. This item is quantified using Bid Item 01987 with a supplemental description specifying the Luciol Systems product. Contact information for a representative of Luciol Systems is:

Nicolas M Skrzypczak  
(248) 890-9454  
NSkrzypczak@LuciolSystems.com

## General Notes & Description of Work

Page 5 of 5

**Removal of Existing Signing and Installation of Proposed Signing.** A quantity of "Remove Sign" has been included in the Remove Sign Summary for removal of various signing along the corridor. An estimated quantity of new signing and sign posts is included on the Signing Summary. Once final surfacing operations are complete, the District Traffic Section will perform ball bank readings along the route to determine the curves requiring curve signing and the appropriate advisory speeds of those curves. Refer to the Special Note for Signing, Special Note for Staking, and Special Note for Signage for more details.

**Edgeline Rumble Strips and Permanent Striping/Markings.** Work involves constructing Edgeline Rumble Strips along with edgeline and various configurations of centerline striping throughout the resurfacing limits. All striping on asphalt is to be 6" thermoplastic while striping on the concrete bridge is to be 6" tape. All centerline striping is to match the existing configurations. The Engineer will make the final determination as to the quantities and placement of Edgeline Rumble Strips and Permanent Pavement Striping/Markings. Refer to the Rumble Strip Standard Drawings for specification details.

**Temporary Striping.** A quantity of Pave Striping – Temp Paint – 4 IN has been included in the contract for potential use in the Superelevation Improvement areas between STA. 605+71 – 610+65, STA. 665+29 – 670+44, and STA. 750+04 – 756+67, and any other areas as directed by the Engineer. The Contractor and Engineer should work together to determine any locations throughout the project requiring temporary pavement striping. The Engineer will make the final determination as to the quantities and placement of temporary pavement striping.

## SPECIAL NOTE FOR DITCHING & SHOULDERING

---

### I. DESCRIPTION

Except as provided herein, all work shall be performed in accordance with Department's Standard Specifications, Interim Supplemental Specifications, applicable Standard and Sepia Drawings, applicable Special Provisions and Special Notes, current editions. Article references are to the Standard Specifications. This project shall consist of furnishing all labor, equipment, materials, and incidentals for the following:

- (1) Maintaining and Controlling Traffic; (2) Site Preparation; (3) Ditching; (4) Shouldering; (5) Constructing Embankments, Embankment Benching, and/or Excavation; (6) Erosion Control; and (7) Any other work as specified in this Contract.

### II. MATERIALS

All materials shall be sampled and tested in accordance with the Department's Sampling Manual and the materials shall be available for sampling a sufficient time in advance of the use of the materials to allow for the necessary time for testing unless otherwise specified in these Notes.

- A. Maintain and Control Traffic.** See Traffic Control Plan.
- B. Erosion Control.** See Special Note for Erosion Control.
- C. DGA.** Furnish Dense Graded Aggregate as per Section 805.
- D. Asphalt Seal Coat.** See the Special Note for Double Asphalt Seal Coat.
- E. Asphalt Seal Aggregate.** See the Special Note for Double Asphalt Seal Coat.
- F. Channel Lining, Class II.** When listed as a bid item, furnish Channel Lining, Class II as per Section 805.
- G. Geotextile Fabric Class 1.** When listed as a bid item, furnish Geotextile Fabric Class 1 as per Section 843.
- H. Crushed Stone Base.** Furnish Crushed Stone Base as per Section 805.

### III. CONSTRUCTION METHODS

- A. Maintain and Control Traffic.** See the Traffic Control Plan.
- B. Erosion Control.** See the Special Note for Erosion Control.

Ditching & Shouldering  
Page 2 of 6

**C. Site Preparation.** Be responsible for all site preparation including, but not limited to: staking; clearing, grubbing, and removal of all obstructions or any other items; excavation, embankment benching, compacting embankment in place; temporary pollution and erosion control; disposal of excess, waste, and debris; and final dressing, cleanup, and seeding and protection. Perform all site preparation as approved or directed by the Engineer.

**D. Staking.** See the Special Note for Staking.

**E. Ditching & Shouldering.** Perform Ditching & Shouldering at the approximate locations listed on the Summary Sheets and/or Plan Sheets, or at locations as directed by the Engineer. All work shall be completed according to Section 209, or as specified in the DITCHING & SHOULDERING AND EMBANKMENT BENCHING DETAILS, the Typical Sections, the Plan Sheets, or as directed by the Engineer. Ditching & Shouldering shall consist of any necessary clearing, grubbing, grading, and/or reshaping of the existing shoulder, ditch, and/or roadside to achieve the proposed shoulder, ditch, and/or roadside dimensions detailed on the Typical Sections. Depending on the existing conditions encountered and to achieve the dimensions as detailed in the Typical Sections, Ditching & Shouldering may also include, but is not limited to: embankment benching, excavating and removing excess material, excavation of rock, providing additional earth material suitable for vegetation growth and grading, shaping, and compacting the earth material.

Provide positive drainage of ditches and slopes at all times during and upon completion of construction. When asphalt surfacing or resurfacing is included in the contract, perform all ditching and as much of the shouldering operations as is practical before beginning final surfacing operations.

**F. Embankment Benching.** Embankment Benching shall be required when the existing groundline has an incline greater than 15%. Any and all required embankment benching shall be incidental to the bid item DITCHING & SHOULERING. For more information refer to the DITCHING & SHOULDERING AND EMBANKMENT BENCHING DETAILS.

**G. DGA Wedge & Chip Seal.** Some, or possibly all, areas of Ditching & Shouldering may be set up to receive a DGA Wedge & Chip Seal after the ditching and shouldering operations are complete. Other areas of Ditching & Shouldering may NOT be set up to receive the DGA Wedge & Chip Seal. See the Summary Sheets and/or Plan Sheets for the approximate locations to receive the DGA Wedge & Chip Seal. The Engineer will determine the exact limits of the DGA Wedge & Chip Seal at the time of construction. Construct and compact the DGA as required by Section 302. Place Chip Seal over the entire width of the DGA Wedge. See the Special Note for Double Asphalt Seal Coat for the Chip Seal requirements.

Ditching & Shouldering  
Page 3 of 6

- H. Channel Lining.** Install Class II Channel Lining along any sections of ditches, fill slopes, or ditch backslopes identified in the Proposal, or any other locations the Engineer directs for slope protection or erosion control. When Channel Lining is proposed to be installed along a steep fill slope in order to establish a width of shoulder (as shown in Figure 5 of the DITCHING & SHOULDERING AND EMBANKMENT BENCHING DETAILS), the Channel Lining is to be capped with Geotextile Fabric Class 1 and 4" of Crushed Stone Base. In lieu of 4" of Crushed Stone Base, 4" of DGA and a Double Asphalt Seal Coat may be specified in the Proposal. Install whichever aggregate capping material the Proposal specifies, or as directed by the Engineer.
- I. Right-of-Way Limits.** The Department has not established exact limits of the Right-of-Way. Unless a consent and release form is obtained from the adjoining property owner, limit work activities to the obvious Right-of-Way and staging areas secured by the Contractor at no additional cost to the Department. In the event that private improvements (i.e. fences, buildings, etc.) encroach upon the Right-of-Way, the contractor shall notify the Engineer and limit work activities in order to NOT disturb the improvements. If they become necessary, the Department will secure consent and releases from property owners through the Engineer. Be responsible for all encroachments onto private lands.
- J. Property Damage.** The Contractor shall be responsible for all damage to public and/or private property resulting from the Contractor's activities. Repair or replace damaged roadway features in like kind materials and design as directed by the Engineer at no additional cost to the Department. Repair or replace damaged private property in like kind materials and design to the satisfaction of the owner and the Engineer at no additional cost to the Department.
- K. Coordination with Utility Companies.** Locate all underground, above ground, and overhead utilities prior to beginning construction. Be responsible for contacting and maintaining liaison with all utility companies that have utilities located within the project limits. Do not disturb existing overhead or underground utilities. It is not anticipated that any utility facilities will need to be relocated and/or adjusted; however, in the event that it is discovered that the work does require that utilities be relocated and/or adjusted, the utility companies will work concurrently with the Contractor while relocating their facilities. Be responsible for repairing all utility damage that occurs due to the Contractor's operations at no additional cost to the Department. NOTIFY THE ENGINEER AND THE UTILITY OWNER(S) IMMEDIATELY WHEN IT IS DISCOVERED OR ANTICIPATED THAT ANY UTILITY CONFLICT COULD DELAY THE CONTRACTOR'S OPERATIONS. If the total delay exceeds ten working days, an extension of the specified completion date will be negotiated with the Contractor for delay to the Contractor's work; however, no extension will be granted for any delay caused by the Contractor's failure to notify the Engineer and/or the utility company as specified above when a conflict is discovered or anticipated as specified.

Ditching & Shouldering  
Page 4 of 6

**L. Caution.** The information in this proposal and the type of work listed herein are approximate only and are not to be taken as an exact evaluation of the materials and conditions to be encountered during construction; the bidder must draw his/her own conclusions when developing the Unit Bid Prices for each bid item. As such, if the conditions encountered are not in accordance with the information shown, the Department does not guarantee any changes to the Unit Bid Prices nor extension of the contract will be considered. The Department will pay for bid item quantity overruns, but only if pre-approved by the Engineer.

**M. Control.** Perform all work under the absolute control of the Department. Obtain the Engineer's approval of all designs required to be furnished by the Contractor prior to incorporation into the work. The Department reserves the right to have other work performed by other contractors and its own forces, and to permit public utility companies and others to do work during the construction within the limits of, or adjacent to, the project. Conduct operations and cooperate with such other parties so that interference with such other work will be reduced to a minimum. The Department will not honor any claims for money or time extension created by the operations of such other parties.

Should a difference of opinion arise as to the rights of the Contractor and others working within the limits of, or adjacent to, the project, the Engineer will decide as to the respective rights of the various parties involved in order to assure the completion of the Department's work in general harmony and in a satisfactory manner, and the Engineer's decision shall be final and binding upon the Contractor.

**N. Clean Up, Disposal of Waste.** Clean up the project area as work progresses. Dispose of all removed excess material, debris, and other waste at approved sites off the Right of Way obtained by the Contractor at no additional cost to the Department. See the Special Provision for Waste and Borrow Sites.

**O. Final Dressing, Seeding and Protection.** Grade all disturbed areas to blend with the adjacent roadways features and to provide a suitable seed bed. Apply Class A Final Dressing to all disturbed areas, both on and off the Right-of-Way. Sow all disturbed earthen areas with the applicable seed mixture(s) according to Section 212.03.03.

#### IV. METHOD OF MEASUREMENT

**A. Maintain and Control Traffic.** See Traffic Control Plan.

**B. Erosion Control.** See Special Note for Erosion Control.

**C. Site Preparation.** Other than the bid items listed, the Department will NOT measure Site Preparation for payment, but shall be incidental to the project bid items.

Ditching & Shouldering  
Page 5 of 6

- D. Staking.** See Special Note for Staking.
  - E. Ditching & Shouldering.** Contrary to Section 209.04 the Department will measure the bid item DITCHING & SHOULERING in linear feet along the centerline of the roadway as the length of the actual ditching and/or shouldering work performed. Further, this measurement will only include one side of the roadway. Therefore, for areas where ditching and shouldering occurs on both sides of the road, the Department will measure each side independently. The Department will not measure cleaning pipe structures 36 inches or less in diameter or reshaping any deformed ends on metal entrance pipes that are to remain in place, as these operations are considered incidental to the bid item DITCHING & SHOULERING.
  - F. Embankment Benching.** The Department will not measure Embankment Benching for payment. Any and all required embankment benching shall be incidental to the bid item DITCHING & SHOULERING.
  - G. DGA, CSB.** When listed as bid items, DGA and Crushed Stone Base shall be measured according to Section 302.04.
  - H. Chip Seal.** When specified in the contract, the bid items associated with Chip Seal shall be measured according to the Special Note for Double Asphalt Seal Coat.
  - I. Channel Lining, Class II.** When listed as a bid item, Class II Channel Lining shall be measured according to Section 703.04.
  - J. Geotextile Fabric, Class 1.** When listed as bid items, Geotextile Fabric, Class 1 shall be measured according to Section 214.04.
  - K. Clean Up, Disposal of Waste, Final Dressing, Seeding and Protection.** The Department will NOT measure for payment the following activities: Clean Up, Disposal of Waste, and Final Dressing. These activities shall be incidental to the project bid items. Seeding and Protection shall be measured according to Section 212.
- V. BASIS OF PAYMENT**
- A. Maintain and Control Traffic.** See Traffic Control Plan.
  - B. Erosion Control.** See Special Note for Erosion Control.
  - C. Staking.** See Special Note for Staking.
  - D. Ditching & Shouldering.** The Department will make payment for the completed and accepted quantities under the bid item DITCHING & SHOULDERING. The Department

Ditching & Shouldering  
Page 6 of 6

will consider payment full compensation for furnishing all labor, materials, equipment, and incidentals necessary to perform Ditching & Shouldering as required by these notes, at the locations indicated on the summary sheets, plans, and/or as directed by the Engineer.

- E. DGA, CSB.** When listed as bid items, the Department will make payment for DGA and Crushed Stone Base according to Section 302.05.
- F. Chip Seal.** When specified in the contract, the Department will make payment for the bid items associated with Chip Seal according to the Special Note for Double Asphalt Seal Coat.
- G. Channel Lining, Class II.** When listed as a bid item, the Department will make payment for Class II Channel Lining according to Section 703.05.
- H. Geotextile Fabric, Class 1.** When listed as a bid item, the Department will make payment for Geotextile Fabric, Class 1 according to Section 214.05.

### SPECIAL NOTE FOR NON-TRACKING TACK COAT

1. DESCRIPTION AND USEAGE. This specification covers the requirements and practices for applying a non-tracking tack asphalt coating. Place this material on the existing pavement course, prior to placement of a new asphalt pavement layer. Use when expedited paving is necessary or when asphalt tracking would negatively impact the surrounding area. This material is not suitable for other uses. Ensure material can “break” within 15 minutes under conditions listed in 3.2.

2. MATERIALS, EQUIPMENT, AND PERSONNEL.

2.1 Non-Tracking Tack. Provide material conforming to Subsection 2.1.1.

2.1.1 Provide a tack conforming to the following material requirements:

Property	Specification	Test Procedure
Viscosity, SFS, 77 ° F	20 – 100	AASHTO T 72
Sieve, %	0.3 max.	AASHTO T 59
Asphalt Residue <sup>1</sup> , %	50 min.	AASHTO T 59
Oil Distillate, %	1.0 max.	AASHTO T 59
Residue Penetration, 77 ° F	20 max.	AASHTO T 49
Original Dynamic Shear (G*/sin δ), 82 ° C	1.0 min.	AASHTO T 315
Softening Point, ° F	149 min.	AASHTO T 53
Solubility, %	97.5 min.	AASHTO T 44

<sup>1</sup> Bring sample to 212 °F over a 10-15 minute period. Maintain 212 °F for 15-20 minutes or until 30-40 mL of water has distilled. Continue distillation as specified in T59.

2.2. Equipment. Provide a distributor truck capable of heating, circulating, and spraying the tack between 170 °F and 180 °F. Do not exceed 180 °F. Circulate the material while heating. As required by the manufacturer, ensure the spray bar is equipped with #1 or #2 ¼” V-slot Etnyre nozzles. Other nozzles are not acceptable. Arrange the nozzles in the following patterns from left to right:

Nozzle number(s)	Activity	Orientation
1	On	Vertical
2	Off	-
3	On	Horizontal
4 & 5	Off	-
6	On	Horizontal
Continue 2 off and 1 on pattern through rest of spray bar system.		

Ensure the bar can be raised to between 14 and 18” from the roadway.

2.3 Personnel. Ensure the tack supplier has provided training to the contractor on the installation procedures for this product. Make a technical representative from the supplier available at the request of the Engineer.

3. CONSTRUCTION.

3.1 Surface Preparation. Prior to the application of the non-tracking tack, ensure the pavement surface is thoroughly dry and free from dust or any other debris that would inhibit adhesion. Clean the surface by scraping, sweeping, and the use of compressed air. Ensure this preparation process occurs shortly before application to prevent the return of debris pavement. If rain is expected within one hour after application, do not apply material. Apply material only when the surface is dry, and no precipitation is expected.

3.2 Non-tracking Tack Application. Ensure the roadway temperature is a minimum of 40 °F and rising during the application of the tack. This material is not suitable for use in colder temperatures. Prior to applying the tack, demonstrate competence in applying the tack according to this note to the satisfaction of the Engineer. Heat the tack in the distributor to between 170 – 180 °F. After initial heating to between 170 – 180 °F, the material may be sprayed between 165 °F and 180 °F. Do not apply outside this temperature range. Apply material at a rate of 0.50 pounds (0.06 gallons) per square yard. Ensure full coverage of the material on the pavement surface. Full coverage of this material is critical. If full coverage is not achieved, material application rate may be increased to ensure full coverage. Do not heat material more than twice in one day.

3.3 Non-tracking Tack Certification. Furnish the tacks certification to the Engineer stating the material conforms to all requirements herein prior to use.

3.4 Sampling and Testing. The Department will require a sample of non-tracking tack be taken from the distributor at a rate of one sample per 15,000 tons of mix. Take two 1 gallon samples of the heated material and forward the sample to the Division of Materials for testing within 7 days. Ensure the product temperature is between 170 and 180 °F at the time of sampling.

4. MEASUREMENT. The Department will measure the quantity of non-tracking tack in tons. The Department will not measure for payment any extra materials, labor, methods, equipment, or construction techniques used to satisfy the requirements of this note. The Department will not measure for payment any trial applications of non-tracking tack, the cleaning of the pavement surface, or furnishing and placing the adhesive. The Department will consider all such items incidental to the non-tracking tack.

5. PAYMENT. The Department will pay for the non-tracking tack at the Contract unit bid price and apply an adjustment for each manufacturer's lot of material based on the degree of compliance as defined in the following schedule. When a sample fails on two or more tests, the Department may add the deductions, but the total deduction will not exceed 100 percent.

Non-Tracking Tack Price Adjustment Schedule						
Test	Specification	100% Pay	90% Pay	80% Pay	50% Pay	0% Pay
Viscosity, SFS, 77 ° F	20 – 100	19 - 102	17 - 18	15 - 16	14	≤13
			103 - 105	106 - 107	108 - 109	≥ 110
Sieve, %	0.30 max.	≤ 0.40	0.41 - 0.50	0.51 - 0.60	0.61 - 0.70	≥ 0.71
Asphalt Residue, %	50 min.	≥49.0	48.5 – 48.9	48.0 – 48.4	47.5-47.9	≤ 47.4
Oil Distillate, %	1.0 max.	≤1.0	1.1-1.5	1.6 - 1.7	1.8-1.9	>2.0
Residue Penetration, 77 ° F	20 max.	≤ 21	22 - 23	24 - 25	26 - 27	≥ 28
Original Dynamic Shear (G*/sin δ), 82 ° C	1.0 min.	≥0.95	0.92 – 0.94	0.90 – 0.91	0.85 - 0.89	≤ 0.84
Softening Point, ° F	149 min.	≥145	142 - 144	140 - 141	138 - 139	≤ 137
Solubility, %	97.5 min.	≥ 97.0	96.8 – 96.9	96.6 – 96.7	96.4 – 96.5	≤ 96.3

<u>Code</u>	<u>Pay Item</u>	<u>Pay Unit</u>
24970EC	Asphalt Material for Tack Non-Tracking	Ton

## SPECIAL NOTES FOR PIPE REPLACEMENTS / EXTENSIONS

---

### I. DESCRIPTION

Except as provided herein, perform all work in accordance with the Department's Standard Specifications, interim Supplemental Specifications, Standard and Sepia Drawings, and Special Notes and Special Provisions, current editions. Article references are to the Standard Specifications. This project shall consist of furnishing all labor, equipment, materials, and incidentals for the following:

- (1) Maintaining and Controlling Traffic; (2) Constructing pipe replacements and/or pipe extensions; (3) Embankment and/or Excavation; (4) Erosion Control; and (6) Any other work as specified by this contract.

### II. MATERIALS

Provide for sampling and testing of all materials in accordance with the Department's Sampling Manual. Make materials available for sampling a sufficient time in advance of the use of the materials to allow for the necessary time for testing unless otherwise specified in these notes.

- A. Maintain and Control Traffic.** See Traffic Control Plan.
- B. Culvert Pipe.** Furnish pipe meeting the requirements of Section 810. Select pipe for pH range Medium and minimum fill cover height according to the applicable Standard or Sepia Drawings, current editions. Verify maximum and minimum fill cover height required for new pipe prior to construction and obtain the Engineer's approval of the class or gauge of pipe and type of coating prior to delivering pipe to project. Furnish approved connecting bands or pipe anchors and toe walls.
- C. Flowable Fill.** Furnish Flowable Fill for Pipe Backfill per Section 601.03.03(B).
- D. Erosion Control.** See Special Note for Erosion Control.

### III. CONSTRUCTION METHODS

- A. Maintain and Control Traffic.** See Traffic Control Plan.
- B. Erosion Control.** See Special Note for Erosion Control.
- C. Site Preparation.** Be responsible for all site preparation including, but not limited to, saw cutting and removing pavement; clearing and grubbing; staking; incidental excavation and backfilling; common and solid rock excavation; embankment in place; removal of obstructions, or any other items; restoration of pavements, slopes, and all disturbed areas; final dressing and cleanup; and disposal of materials. Limit clearing and grubbing to the absolute minimum required to construct the drainage features. Perform all site preparation only as approved or directed by the Engineer.

Pipe Replacements/Extensions  
Page 2 of 5

- D. Removing Headwalls, Pipe, and Excavation.** Remove existing headwalls and lengths of culvert and/or entrance pipes at the approximate locations noted on the summary. The Engineer will determine the exact locations and lengths of pipe to be removed at the time of construction. When removing pipe, or any portion of pipe under the roadway, saw cut the existing asphalt pavement and base to a neat edge prior to excavation and removal of the existing pipe. NOTE: Saw cutting the pavement shall be incidental. Obtain the Engineer's approval of trench width and/or saw cutting limits prior to saw cutting the pavement. Excavate the trench and remove the pipe as directed, or approved, by the Engineer without disturbing existing underground utilities.
- E. Constructing Pipe, Headwalls, and Drainage Boxes.** Construct culvert and/or entrance pipes, pipe extensions, headwalls, drainage boxes, and other drainage structures at the locations shown in the proposal or as designated by the Engineer. The contractor will establish, with the approval of the Engineer, the final centerlines, flow lines, and skews to obtain the best fit with the existing and/or proposed ditches and other proposed improvements. (See the Special Note for Staking.) Construct pipe bedding according to Section 701 and the applicable Standard or Sepia Drawings, current editions. Use approved connecting bands or concrete anchors as required. Prior to backfilling pipe, obtain the Engineer's approval of the pipe installation. Provide Positive drainage upon completion of pipe installation.
- F. Pipe Backfill.** Backfill entrance pipes according to Section 701.03.06. Contrary to Section 701.03.06, backfill culvert pipes with flowable fill for the width of the roadway and as shown on the Pipe Replacement Detail. Steel plates will likely be required to maintain traffic while the flowable fill cures. Once the flowable fill has sufficiently cured, place the Asphalt Base in lifts with thicknesses of 3-4 inches, up to the surface of the existing pavement. Seal with Leveling & Wedging. Allow the asphalt base and leveling & wedging to be exposed to traffic for a minimum of 14 days to allow for settlement. During the waiting period, level & wedge any settlement as directed by the Engineer. After the waiting period has been met for the last pipe replacement constructed, the final milling and/or surfacing operations can begin, unless directed otherwise by the Engineer.
- G. Embankments.** Backfill pipe and culvert extensions, and construct shoulder embankments as directed by the Engineer. The contractor shall bench into the existing slope and apply proper compaction according to Section 206. For more information and details on benching, refer to Note 2 on the detail sheet titled: DITCHING & SHOULDERING AND EMBANKMENT BENCHING DETAILS, found elsewhere in the Proposal. Provide positive drainage of ditches, shoulders, and slopes at all times during, and upon completion of construction.
- H. Property Damage.** Be responsible for all damage to public and/or private property resulting from the work. Repair or replace damaged roadway features in like kind materials and design, as directed by the Engineer at no additional cost to the Department. Repair or replace damaged private property in like kind materials and design to the satisfaction of the owner and the Engineer at no additional cost to the Department.

Pipe Replacements/Extensions  
Page 3 of 5

- I. Coordination with Utility Companies.** Locate all underground, above ground, and overhead utilities prior to beginning construction. Be responsible for contacting and maintaining liaison with all utility companies that have utilities located within the project limits. Do not disturb existing overhead or underground utilities. It is not anticipated that any utility facilities will need to be relocated and/or adjusted; however, in the event that it is discovered that the work does require that utilities be relocated and/or adjusted, the utility companies will work concurrently with the Contractor while relocating their facilities. Be responsible for repairing all utility damage that occurs as a result of pipe replacement and pipe extension operations at no additional cost to the Department. NOTIFY THE ENGINEER AND THE UTILITY OWNER(S) IMMEDIATELY WHEN IT IS DISCOVERED OR ANTICIPATED THAT ANY UTILITY CONFLICT COULD DELAY THE CONTRACTOR'S OPERATIONS. If the total delay exceeds ten working days, an extension of the specified completion date will be negotiated with the Contractor for delay to the Contractor's work; however, no extension will be granted for any delay caused by the Contractor's failure to notify the Engineer and/or the utility company as specified above when a conflict is discovered or anticipated as specified.
- J. Right-of-Way Limits.** The Department has not established exact limits of the Right-of-Way. Unless a consent and release form is obtained from the adjoining property owner, limit work activities to the obvious Right-of-Way and staging areas secured by the Contractor at no additional cost to the Department. In the event that private improvements (i.e. fences, buildings, etc.) encroach upon the Right-of-Way, the contractor shall notify the Engineer and limit work activities in order to NOT disturb the improvements. If they become necessary, the Department will secure consent and releases from property owners through the Engineer. Be responsible for all encroachments onto private lands.
- K. Clean Up, Disposal of Waste.** Clean up the project area as work progresses. Dispose of all removed concrete, pipe, pavement, debris, excess and unsuitable excavation, and all other waste at approved sites off the Right of Way obtained by the Contractor at no additional cost to the Department. See the Special Provision for Waste and Borrow Sites.
- L. Final Dressing, Seeding and Protection.** Grade all disturbed areas to blend with the adjacent roadways features and to provide a suitable seed bed. Apply Class A Final Dressing to all disturbed areas, both on and off the Right-of-Way. Sow all disturbed earthen areas with the applicable seed mixture(s) according to Section 212.03.03.
- M. Erosion Control.** See the Special Note for Erosion Control.

**IV. METHOD OF MEASUREMENT**

- A. Maintain and Control Traffic.** See the Traffic Control Plan.
- B. Site Preparation.** Other than the bid items listed, site preparation will NOT be measured for payment, but shall be incidental to culvert and/or entrance pipe bid items, as applicable.

Pipe Replacements/Extensions  
Page 4 of 5

- C. Remove Headwall.** The Department will measure the removal of existing headwalls as Each. Any excavation, including rock excavation, necessary to remove existing headwalls will NOT be measured for payment, but shall be incidental to the bid item "Remove Headwall".
- D. Remove Pipe.** Removal of existing culvert and entrance pipe shall be measured according to Section 701.04.14. Any excavation, including rock excavation, necessary to remove existing pipe will NOT be measured for payment, but shall be incidental to the bid item "Remove Pipe".
- E. Culvert and Entrance Pipe.** The Department will measure the quantities according to Section 701.04. Any excavation, including rock excavation, necessary to install culvert or entrance pipe shall be incidental to the corresponding pipe bid items.
- F. Headwalls, Drainage Boxes.** The Department will measure according to Section 710. Any excavation, including rock excavation, necessary to construct headwalls and/or drainage boxes will NOT be measured for payment, but shall be incidental to the applicable bid item.
- G. Excavation, Pipe Backfill, Embankments.** The Department will NOT measure for payment the following items: any excavation, including rock excavation, necessary to remove the existing pipe and/or install the proposed culvert or entrance pipe, pipe backfill material, flowable fill, and re-constructing shoulder embankments, but shall considered these items incidental to the bid items for culvert and entrance pipe.
- H. Clean Up, Disposal of Waste, Final Dressing, Seeding and Protection.** The Department will NOT measure for payment the following activities: Clean Up, Disposal of Waste, and Final Dressing. These activities shall be incidental to the project bid items. Seeding and Protection shall be measured according to Section 212.
- I. Erosion Control.** See the Special Note for Erosion Control.

**V. BASIS OF PAYMENT**

- A. Maintain and Control Traffic.** See the Traffic Control Plan.
- B. Remove Headwall.** The Department will make payment for the completed and accepted quantities of Each headwall removed. Payment at the Contract unit price per Each shall be full compensation for furnishing all labor, materials, equipment, and incidentals for removing the existing headwall.
- C. Remove Pipe.** The Department will make payment according to Section 701.05. Payment at the Contract unit price per linear foot shall be full compensation for furnishing all labor, materials, equipment, and incidentals for removing the existing pipe.
- D. Culvert and Entrance Pipe.** The Department will make payment according to Section

Pipe Replacements/Extensions  
Page 5 of 5

701.05. Payment at the Contract unit price per linear foot shall be full compensation for furnishing all labor, materials, equipment, and incidentals necessary for installing and backfilling new culvert and entrance pipe.

**E. Headwalls, Drainage Boxes.** The Department will make payment according to Section 710.

**F. Erosion Control.** See the Special Note for Erosion Control.

## **SPECIAL NOTE FOR EROSION CONTROL**

---

### **I. DESCRIPTION**

Perform all erosion and water pollution control work in accordance with any other notes in the Proposal, the Department's Standard and Interim Supplemental Specifications, the Special Provisions and Special Notes, and the Standard and Sepia Drawings, current editions, or as directed by the Engineer. Section references are to the Standard Specifications. This work shall consist of:

(1) Developing and preparing a Best Management Practices Plan (BMP) tailored to suit the specific construction phasing for each site within the project; (2) Preparing the project site for construction, including locating, furnishing, installing, and maintaining temporary and/or permanent erosion and water pollution control measures as required by the BMP prior to beginning any earth disturbing activity on the project site; (3) Clearing and grubbing and removal of all obstructions as required for construction; (4) Removing all erosion control devices when no longer needed; (5) Restoring all disturbed areas as nearly as possible to their original condition; (6) Preparing seedbeds and permanently seeding all disturbed areas; (7) Providing a Kentucky Erosion Prevention and Sediment Control Program (KEPSC) qualified inspector; and (8) Performing any other work to prevent erosion and/or water pollution as specified by this contract, required by the BMP, or as directed by the Engineer.

### **II. MATERIALS**

Furnish materials in accordance with these notes, the Standard Specifications and Interim Supplemental Specifications, applicable Special Provisions and Special Notes, and the Standard and Sepia Drawings, current editions. Provide for all materials to be sampled and tested in accordance with the Department's Sampling Manual. Unless directed otherwise by the Engineer, make the materials available for sampling a sufficient time in advance of the use of the materials to allow for the necessary time for testing.

### **III. CONSTRUCTION**

Be advised, these Erosion Control Notes do not constitute a BMP plan for the project. Jointly with the Engineer, prepare a site specific BMP plan for each drainage area within the project in accordance with Section 213. Provide a unique BMP at each project site using good engineering practices taking into account existing site conditions, the type of work to be performed, the construction phasing, methods, and the techniques to be utilized to complete the work. Be responsible for all erosion prevention, sediment control, and water pollution prevention measures required by the BMP for each site. Represent and warrant compliance with the Clean Water Act (33 USC Section 1251 et seq.), the 404 Permit, the 401 Water Quality Certification, and applicable state and local government agency laws, regulations, rules, specifications, and permits. Contrary to Section 105.05, in case of discrepancy between these notes, the Standard Specifications, Interim Supplemental Specifications, Special Provisions and Special Notes, Standard and Sepia Drawings, and such state and local government agency requirements, adhere to the most restrictive requirement.

## Erosion Control Page 2 of 3

Conduct operations in such a manner as to minimize the amount of disturbed ground during each phase of the construction and limit the haul roads to the minimum required to perform the work. Preserve existing vegetation not required to be removed by the work or the contract. Seed and/or mulch disturbed areas at the earliest opportunity. Use silt fence, silt traps, temporary ditches, brush barriers, erosion control blankets, sodding, channel lining, and other erosion control measures in a timely manner as required by the BMP and as directed or approved by the Engineer. Prevent sediment laden water from leaving the project, entering an existing drainage structure, or entering a stream.

Provide for erosion control measures to be in place and functioning prior to any earth disturbance within a drainage area. Compute the volume and size of silt control devices necessary to control sediment during each phase of construction. All silt control devices shall be sized to retain a volume of 3,600 cubic feet per disturbed contributing acre. Remove sediment from silt traps before they become a maximum of ½ full. Maintain silt fence by removing accumulated trappings and/or replacing the geotextile fabric when it becomes clogged, damaged, or deteriorated, or when directed by the Engineer. Properly dispose of all materials trapped by erosion control devices at approved sites off the right of way obtained by the Contractor at no additional cost to the Department. See the Special Provision for Waste and Borrow Sites.

As work progresses, add or remove erosion control measures as required by the BMP, applicable to the Contractor's project phasing, construction methods, and techniques. Update the volume calculations and modify the BMP as necessary throughout the duration of the project. Ensure that an updated BMP is kept on site and available for public inspection throughout the life of the project.

The required volume at each Silt Trap shall be computed based on the Up Gradient Contributing Areas that are disturbed and/or stabilized to the satisfaction of the Engineer. The required volume calculation for each Silt Trap shall be determined by the Contractor and verified by the Engineer. The required volume at each Silt Trap may be reduced by the following amounts:

- Up Gradient Areas not disturbed (acres)
- Up Gradient Areas that have been reclaimed and protected by Erosion Control Blanket or other ground protection material such as Temporary Mulch (acres)
- Up Gradient Areas that have been protected by Silt Fence (acres) – Areas protected by Silt Fence shall be computed at a maximum rate of 100 square feet per linear foot of Silt Fence
- Up Gradient Areas that have been protected by Silt Traps (acres)

The use of Temporary Mulch is encouraged.

Silt Trap Type B shall always be placed at the collection point prior to discharging into a Blue Line Stream or onto an adjacent Property Owner. Where overland flow exists, a Silt Fence or other filter devices may be used.

After all construction is complete, restore all disturbed areas in accordance with Section 212. Completely remove all temporary erosion control devices not required as part of the permanent erosion control from the construction site. Prior to removal, obtain the Engineer's concurrence of items to be removed. Grade the remaining exposed earth (both on and off the Right-of-Way) as nearly

Erosion Control  
Page 3 of 3

as possible to its original condition, or as directed by the Engineer. Prepare the seed bed areas and sow all exposed earthen areas with the applicable seed mixture(s) according to Section 212.03.03.

**IV. MEASUREMENT**

The Department will measure the various erosion control items according to Section 212.04 and Section 213.04, as applicable.

**V. BASIS OF PAYMENT**

The Department will make payment for the various erosion control items according to Section 212.04 and Section 213.04, as applicable.

## SPECIAL NOTE FOR SIGNING

---

### I. DESCRIPTION

Except as provided herein, this work shall be performed in accordance with the current edition of the Manual on Uniform Traffic Control Devices (MUTCD), the Department's current Standard Specifications and Interim Supplemental Specifications, applicable Standard and Sepia Drawings, and applicable Special Provisions. Article references are to the Standard Specifications. This project shall consist of furnishing all labor, equipment, materials, and incidentals for the following:

- (1) Maintaining and Controlling Traffic; (2) Furnish, Fabricate, and Erect Signs; and
- (3) All other work specified in the Contract.

### II. MATERIALS

All materials shall be sampled and tested in accordance with the Department's Sampling Manual and the materials shall be available for sampling a sufficient time in advance of the use of the materials to allow for the necessary time for testing unless otherwise specified in these Notes.

- A. **Maintain and Control Traffic.** See Traffic Control Plan.
- B. **Erosion Control.** See Special Note for Erosion Control.

### III. CONSTRUCTION METHODS

- A. **Maintain and Control Traffic.** See Traffic Control Plan.
- B. **Site Preparation.** Be responsible for all site preparation including, but not limited to: clearing and grubbing, staking, excavation, backfill, and removal of obstructions or any other material not covered by other items. Perform all site preparation only as approved, or directed, by the Engineer.
- C. **Staking.** See Special Note for Staking.
- D. **Signs and Posts.** Before beginning installation, the Contractor shall furnish to the Engineer drawings, descriptions, manufacturer's cuts, etc. covering all material to be used. Mill test reports for beams, steel panels, and each different gauge of aluminum or steel sheeting used must be submitted to the Division of Construction and approved prior to erection.

Fabricate sheet signs from .080 or .125 gauge aluminum alloy 5052-H38 or 6061-T6, in accordance with ASTM B-209, and to the size and shape specified. Prepare the side of the sheet to be used as the sign face to receive the retroreflective background material

## Signing

Page 2 of 6

according to the recommendations of the sheeting and retroreflective material manufacturer(s). Sheeting used as background material for sign faces is to be the color specified and visually in accordance with the standard requirements of ASTM D-4956, and meet the requirements of Section 830 of the Standard Specifications. Contrary to Section 830.02.06, only the types and colors of sheeting as specified in the proposal will be accepted. All retroreflective material shall be fabricated and assembled in accordance with the specifications and/or recommendations of the manufacturer(s).

All hardware for the erection of sheeting signs shall be rust resistant: stainless steel, zinc coated, aluminum, or an Engineer approved material. All beams and posts shall be of sufficient lengths to extend from the top of the sign to the required embedment in the anchor. Splicing of the sign post shall NOT be allowed. For installations in soil, Type I steel posts shall be mounted on either a standard anchor, with soil stabilizer plate, or on a Type D breakaway sign support. Refer to Sheeting Sign Detail Sheet 1 of 2 for installation details for a standard anchor with soil stabilizer plate. When installing a standard anchor with soil stabilizer plate, if solid rock is encountered, the Contractor shall drill a hole to the required depth into the rock, install the anchor into the hole, and backfill the anchor post with concrete, or other method approved by the Engineer. The cost shall be incidental to Type I steel post, and a soil stabilizer plate will not be required. Refer to Standard Drawing RGX-065, current edition, for installation details of Type D breakaway sign supports. Approved manufacturers for Type D breakaway sign supports have been placed on the list of approved materials. For installations on existing concrete, such as a sidewalk, concrete median, etc., Type I steel posts shall be mounted on a Type D surface mount. For Type D surface mounts use only Kleen Break Model 425 for Surface Mount Concrete Installations by Xcessories Squared of Auburn, IL. Prior to installation, the Contractor shall submit to the Engineer shop drawings of the Type D surface mount(s). Install the Type D surface mount(s) according to all the applicable requirements of the manufacturer (see shop drawings). All steel post shall meet the requirements of Section 832. All hardware including, but not limited to, sign post anchors, soil stabilizer plates, nuts, bolts, washers, fasteners, fittings, and bracing, or any other incidentals necessary to erect the signs shall be furnished by the Contractor and will be incidental to the work.

New concrete bases, posts, support anchors, signs, etc. are to be installed prior to dismantling any existing sign(s). The removal of existing signs, posts, and support anchors is to be performed concurrently with the installation of new signs, posts, and support anchors, under the same lane closure during the same work shift. Completely remove existing sign support anchors or remove them to a minimum depth of six (6) inches below existing ground line and backfill the disturbed area to the existing ground line.

When listed in the summaries, Reflective Sign Post Panels shall be 2" wide x 60" tall (or 84" tall for urban installations) and shall have three 3/8" holes (one hole in the top 3", one hole near the center, and one hole in the bottom 3") that align with the holes on the Type I steel post. Sheeting for the Reflective Sign Post Panels shall be the same Type and color as the sign installed on the post. Examples include:

Signing  
Page 3 of 6

- Red, fluorescent yellow, and fluorescent yellow-green (Type XI Sheeting)
- White and yellow (Type XI Sheeting).

All manufactured sheeting signs shall be free of visual defects including, but not limited to: cracks, tears, ridges, humps, discoloration, etc., and defective signs shall be replaced at no additional cost to the Department.

All sign blanks shall be hole punched by the manufacturer for either horizontal or vertical installation. Attach all aluminum sheeting signs to square post with 3/8" all steel rivets and nylon washers.

Post will be attached to the anchor with 5/16" corner bolts and 5/16" flanged nuts, and all post and anchor cuts shall be treated with a Cold Galvanizing Compound spray.

Sign posts shall be erected vertically by using a bubble level. The tolerance shall be a two (2) degree angle in any direction. For locations where there are more than one sign is mounted beside each other, the posts shall be spaced to provide approximately six inches (6") of spacing between signs.

- E. Property Damage.** The Contractor shall be responsible for all damage to public and/or private property resulting from the Contractor's activities. Repair or replace damaged roadway features in like kind materials and design as directed by the Engineer at no additional cost to the Department. Repair or replace damaged private property in like kind materials and design to the satisfaction of the owner and the Engineer at no additional cost to the Department.
- F. Coordination with Utility Companies.** Locate all underground, above ground, and overhead utilities prior to beginning construction. Be responsible for contacting and maintaining liaison with all utility companies that have utilities located within the project limits. Do not disturb existing overhead or underground utilities. It is not anticipated that any utility facilities will need to be relocated and/or adjusted; however, in the event that it is discovered that the work does require that utilities be relocated and/or adjusted, the utility companies will work concurrently with the Contractor while relocating their facilities. Be responsible for repairing all utility damage that occurs due to the Contractor's operations at no additional cost to the Department. NOTIFY THE ENGINEER AND THE UTILITY OWNER(S) IMMEDIATELY WHEN IT IS DISCOVERED OR ANTICIPATED THAT ANY UTILITY CONFLICT COULD DELAY THE CONTRACTOR'S OPERATIONS. If the total delay exceeds ten working days, an extension of the specified completion date will be negotiated with the Contractor for delay to the Contractor's work; however, no extension will be granted for any delay caused by the Contractor's failure to notify the Engineer and/or the utility company as specified above when a conflict is discovered or anticipated as specified.

Signing  
Page 4 of 6

**G. Caution.** The information in this proposal and the type of work listed herein are approximate only and are not to be taken as an exact evaluation of the materials and conditions to be encountered during construction; the bidder must draw his/her own conclusions when developing the Unit Bid Prices for each bid item. As such, if the conditions encountered are not in accordance with the information shown, the Department does not guarantee any changes to the Unit Bid Prices nor extension of the contract will be considered. The Department will pay for bid item quantity overruns, but only if pre-approved by the Engineer.

**H. Control.** Perform all work under the absolute control of the Department. Obtain the Engineer's approval of all designs required to be furnished by the Contractor prior to incorporation into the work. The Department reserves the right to have other work performed by other contractors and its own forces, and to permit public utility companies and others to do work during the construction within the limits of, or adjacent to, the project. Conduct operations and cooperate with such other parties so that interference with such other work will be reduced to a minimum. The Department will not honor any claims for money or time extension created by the operations of such other parties.

Should a difference of opinion arise as to the rights of the Contractor and others working within the limits of, or adjacent to, the project, the Engineer will decide as to the respective rights of the various parties involved in order to assure the completion of the Department's work in general harmony and in a satisfactory manner, and the Engineer's decision shall be final and binding upon the Contractor.

**I. Clean Up, Disposal of Waste.** Clean up the project area as work progresses. Dispose of all removed concrete, debris, and other waste as per Section 204.03.08. The Department will incur no cost to obtain the disposal sites. The Department will NOT make direct payment for disposal of waste and debris from the project. Existing anchors, signs, posts, and any other hardware or material removed from the site are to become the property of the Contractor. See Special Provision for Waste and Borrow Sites.

**J. Final Dressing, Seeding and Protection.** Grade all disturbed areas to blend with the adjacent roadways features and to provide a suitable seed bed. Apply Class A Final Dressing to all disturbed areas, both on and off the Right-of-Way. Sow all disturbed earthen areas with the applicable seed mixture(s) according to Section 212.03.03.

**K. Erosion Control.** See Special Note for Erosion Control.

#### IV. METHOD OF MEASUREMENT

**A. Maintain and Control Traffic.** See Traffic Control Plan.

Signing  
Page 5 of 6

- B. Site Preparation.** Other than the bid items listed, the Department will NOT measure Site Preparation for payment, but shall be incidental to the project bid items.
- C. Signs.** The Department will measure the finished in-place area of signs in Square Feet.
- D. Sign Posts.** The Department will measure the finished in-place length of sign posts in Linear Feet, from the top of the anchor, or top of the sign support, to the top of the sign post. Laps, cutoffs, excess, and waste will NOT be measured for payment.
- E. Type D Breakaway Sign Supports.** The Department will measure Type D sign supports as Each support installed.
- F. Type D Surface Mounts.** The Department will measure Type D Surface Mounts as Each surface mount installed.
- G. Class A Concrete for Signs.** The Department will measure the Class A Concrete used in conjunction with Type D breakaway sign support installations in Cubic Yards. Any concrete that is required as backfill due to hitting rock during a standard installation shall be incidental to the bid item STEEL POST TYPE I, and soil stabilizers will not be required.
- H. Clean Up, Disposal of Waste, Final Dressing, Seeding and Protection.** The Department will NOT measure for payment the following activities: Clean Up, Disposal of Waste, and Final Dressing. These activities shall be incidental. Seeding and Protection shall be measured according to Section 212.
- I. Erosion Control.** See Special Note for Erosion Control.
- J. Remove Sign.** The Department will consider all signs attached to one or more connected posts as a single sign. The Department will measure as Each sign assembly removed and NOT each individual sign removed.
- K. Items Provided by KYTC.** The Department will NOT measure for payment the installation of signs and/or surface mounts provided by KYTC. These activities shall be incidental to the bid item STEEL POST TYPE I.

**V. BASIS OF PAYMENT**

- A. Maintain and Control Traffic.** See Traffic Control Plan.
- B. Signs.** The Department will make payment for the completed and accepted quantities under the bid item SBM ALUM SHEET SIGNS .125 IN or .080 IN. The Department will consider payment full compensation for all work and incidentals necessary to install the

Signing  
Page 6 of 6

signs, as required by these notes and the details found elsewhere in the proposal, at the locations indicated on the summary sheets, plans, and/or as directed by the Engineer.

- C. Sign Posts.** The Department will make payment for the completed and accepted quantities under the bid item STEEL POST TYPE I. The Department will consider payment full compensation for all work and incidentals necessary to install the sign posts as required by these notes and the details found elsewhere in the proposal.
- D. Type D Breakaway Sign Supports.** The Department will make payment for the completed and accepted quantities under the bid item GMSS TYPE D. The Department will consider payment full compensation for all work and incidentals necessary to install the Type D breakaway sign supports as required by Standard Drawing RGX-065, current edition.
- E. Type D Surface Mounts.** The Department will make payment for the completed and accepted quantities under the bid item GMSS TYPE D Surface Mount. The Department will consider payment full compensation for all work and incidentals necessary to install the Type D surface mounts according to all applicable manufacturer requirements.  
NOTE: There are two permissible Type D Surface Mount alternatives: Kleen Break Model 425 for Surface Mount Concrete Installations by Xcessories Squared of Auburn, IL
- F. Class A Concrete for Signs.** The Department will make payment for the completed and accepted quantities, used in conjunction with Type D breakaway sign support installations, under the bid item CLASS A CONCRETE FOR SIGNS. The Department will consider payment full compensation for all work and incidentals necessary to install the concrete as required by Standard Drawing RGX-065, current edition.
- G. Remove Sign.** The Department will make payment for the completed and accepted quantities under the bid item REMOVE SIGN. The Department will consider payment full compensation for all work and incidentals necessary to remove the existing signs, posts, anchors, and any other sign material or hardware, from the locations indicated on the summary sheets, plans, and/or as directed by the Engineer.
- H. Erosion Control.** See Special Note for Erosion Control.

## SPECIAL NOTE FOR SIGNAGE

---

The final advisory speeds and some sign types will have to be determined after the curve superelevation improvements and final surfacing operations have been completed. The Contractor shall notify the Engineer and District Traffic Engineer when all of the superelevation improvements and surfacing operations have been completed. Once notified, the District Traffic Engineer will ball-bank the newly surfaced route to determine the appropriate advisory speeds and work with the Contractor to determine the final Signing Plan. The Engineer and/or District Traffic Engineer will provide the Contractor with the final advisory speeds, any changes to proposed sign types, and the final quantities within three (3) weeks of being notified by the Contractor that final surfacing operations are complete. After the Contractor has received this information from the Engineer and/or the District Traffic Engineer, the Contractor shall then proceed to layout and stake the signing according to the Special Note for Staking, included elsewhere in this proposal.

All sign sheeting shall be from the Cabinet's List of Approved Materials.

All permanent signs and sign components shall be fabricated using Type XI sheeting.

The following signs and sign components shall be fabricated using Type XI fluorescent yellow sheeting:

- Horizontal Alignment Signs and Plaques, including signs shown in Figure 2C-1 of the MUTCD
- All Advisory Speed (W13-1P) plaques

The following signs shall be fabricated using Type XI fluorescent yellow-green sheeting:

- School and school bus warning signs, including the fluorescent yellow-green signs shown in Figures 7B-1 and 7B-6 of the MUTCD and other school-related warning signs that are not included in the MUTCD.
- Bicycle Warning (W11-1) signs and SHARE THE ROAD (W16-1P) plaques or diagonal downward pointing arrow (W16-7P) plaques that supplement Bicycle Warning signs.
- Pedestrian Warning signs and diagonal downward pointing arrow plaques that supplement Pedestrian Warning signs.
- In-Street Pedestrian Crossing (R1-6) signs and Overhead pedestrian Crossing (R1-9) signs
- Supplemental plaques to any of the previously listed signs

## SPECIAL NOTE FOR STAKING

---

Perform Contractor Staking according to Section 201; except, in addition to the requirements of Section 201, perform the following:

1. Contrary to Section 201, perform items 1-3 usually performed by the Engineer.
2. Using the proposed pavement superelevation rates, runout, and runoff lengths, determine the necessary changes in pavement edge elevation along the curves and the transitions leading into and out of the curve to achieve the proposed superelevation improvements. The intent is to provide a consistent superelevation throughout the curves and smooth transitions into and out of the curves. Once the proposed changes in pavement edge elevations are determined and prior to starting paving operations, verify the proposed roadside re-grading along the curve can be constructed so that the new roadside is flush with the new pavement edge elevation and the new toe of slope, or top of cut, will remain within the existing Right-of-Way and/or not impact a sensitive obstruction. If necessary, and with the approval of the Engineer, reduce the proposed superelevation rate of a curve if the new edge of pavement elevation will cause the new roadside grading to extend beyond the Right-of-Way and/or impact a sensitive obstruction. Alternatively, with the approval of the Engineer and to the extent allowable by the "Ditching & Shouldering and Embankment Benching Details" and/or the Special Note for Ditching & Shouldering, the Contractor may be allowed to make adjustments to the roadside grading so the proposed roadside re-grading will remain within the existing Right-of-Way and/or not impact a sensitive obstruction. After the final proposed changes in pavement edge elevations are determined and before paving operations begin, submit to the Engineer and obtain approval for the number of asphalt lifts, each asphalt lift's thickness, and the mix design of each lift of Leveling & Wedging the contractor plans to use to achieve the superelevation improvement. Ensure positive drainage upon completion of the work.
3. Verify the dimensions, type, and quantities of the culvert pipes, entrance pipes, and/or box culverts as listed and detailed in the proposal, and determine flow line elevations and slopes necessary to provide positive drainage. Revise as necessary to accommodate the existing site conditions; to provide proper alignment of the drainage structures with existing and/or proposed ditches, stream channels, swales, and the roadway lines and grades; and to ensure positive drainage upon completion of the work.
4. Using stakes, paint marks on the pavement, mag nails, and/or any other means approved by the Engineer, the Contractor shall mark and/or stake the proposed sign locations in the field. NOTE: The proposed signs are listed in the proposal by approximate location and are NOT to be taken as the exact location for the signs. During staking operations the Contractor shall review the signing layout and existing field conditions and look for potential conflicts, including but not limited to utilities, driveways, visual obstructions, etc. When conflicts are found, adjust the staked location of signs to mitigate conflicts. Because the sign locations in the proposal are approximate and the location of some signs may need to be adjusted due to conflicts, during staking operations the Contractor shall refer to and utilize the information in the Manual on Uniform on Traffic Control Devices

Staking  
Page 2 of 2

(MUTCD), current edition. The MUTCD cover items such as: appropriate sign location, advance placement distances, and spacing requirements for signing. The intent is for the proposed signs to be consistent with, and meet the requirements of, the MUTCD. Once the proposed sign locations have been staked, notify and coordinate with the District Traffic Engineer, and perform a review of the staked locations. Adjust the staked locations, as directed by the District Traffic Engineer and obtain approval of the final staked locations. This review will also be used to determine if there are any existing signs that require removal and/or relocation. Provide the District Traffic Engineer with 2 weeks of notice when a route will be ready for a review of the staked locations. NOTE: The District Traffic Engineer may determine that the proposed signing, including sign types and messages, needs to be adjusted and/or modified from what is shown in the proposal. Therefore, the Contractor shall not order any sign material for a route until the route has been staked and final sign location approval has been given by the District Traffic Engineer.

5. Produce and furnish to the Engineer "As Built" information for the superelevation improvements and the drainage improvements. For superelevation improvements, as built information will consist of a record of the final pavement cross slopes every 50 feet, for each lane of travel along the curves and the transitions into and out of the curves. Elevation data of the curve improvements is not necessary; simply the cross slope percentage every 50 feet. For the drainage improvements, as built information will consist of a final record of the actual types, sizes, and locations of the drainage structures (i.e. box inlets, headwalls, junction boxes, etc.), culvert pipes, and/or box culverts constructed. Final elevation data of the drainage improvements is not necessary.
6. Using paint marks on the pavement, and/or any other means approved by the Engineer, the Contractor shall layout and pre-mark the proposed striping, pavement markings, etc. Adjust as necessary to accommodate the existing site conditions and to provide proper alignment of the proposed thru and turning lanes. Obtain approval of the pre-marked layout from the Engineer and/or District Traffic Engineer prior to installing the striping and/or pavement markings.
7. Prior to incorporating into the work, obtain the Engineers approval of all revisions determined by the Contractor.
8. Perform any and all other staking operations required to control and construct the work.

## **SPECIAL NOTE FOR SHOULDER MILLING/TRENCHING**

---

Trench shoulders as shown on the Typical Section. The Engineer may eliminate locations along the route from shoulder trenching (e.g. road approaches, turn lanes, entrances, etc.). For entrances and road approaches, the Engineer will determine whether to omit the trenching or continue the trenching across the entrance or approach. **DO NOT** trench across entrances or road approaches without the Engineer's approval. If trenching is achieved by means other than milling, saw cut the pavement 4 inches deep to create a smooth edge prior to excavating the shoulder trench. Excavate the material from the shoulder and maintain the proposed cross-slope as shown on the Typical Sections. The intent is to mill, or excavate, the entire trench so that the proposed shoulder slope is retained at the end of the paving operation. Reshape and compact excavated material from the trench on the outside edge of the newly paved shoulder as shown on the Typical Section.

Retain possession of excess materials and/or materials the Engineer deems unsuitable for reuse and waste the materials off the right-of-way at sites obtained by the Contractor at no additional cost to the Department. See Special Provision for Waste and Borrow.

Accept payment at the contract unit price per square yard for SHOULDER MILLING/TRENCHING as full compensation for all labor, materials, equipment, and incidentals for excavating the shoulder trench and reuse and/or disposal of the excavated material.

## **SPECIAL NOTES FOR COMPLETION DATES & LIQUIDATED DAMAGES**

---

The ultimate fixed completion date for this project will be August 31, 2021. Liquidated Damages for failure to complete the project on time will be assessed following Section 108.09.

In addition to the requirements of Section 108.09, the Department will assess Liquidated Damages in the amount of **\$1,000** per hour for each hour, or fraction of an hour, for any and all lane closures that are in place beyond the time frame(s) noted in the Traffic Control Plan and approved by the Engineer.

Contrary to Section 108.09, Liquidated Damages will be assessed for the months of December through March.

Contrary to Section 108.09, Liquidated Damages will be assessed regardless of whether seasonal limitations prohibit the Contractor from performing work on the controlling operation.

All liquidated damages will be applied accumulatively.

All other applicable portions of Section 108 apply.

## **SPECIAL PROVISION FOR WASTE AND BORROW SITES**

Obtain U.S. Army Corps of Engineer's approval before utilizing a waste or borrow site that involves "Waters of the United States". The Corps of Engineers defines "Waters of the United States" as perennial or intermittent streams, ponds or wetlands. The Corps of Engineers also considers ephemeral streams, typically dry except during rainfall but having a defined drainage channel, to be jurisdictional waters. Direct questions concerning any potential impacts to "Waters of the United States" to the attention of the appropriate District Office for the Corps of Engineers for a determination prior to disturbance. Be responsible for any fees associated with obtaining approval for waste and borrow sites from the U.S. Army Corps of Engineer or other appropriate regulatory agencies.

1-296 Waste & Borrow Sites  
01/02/2012

## **COORDINATION OF WORK WITH OTHER CONTRACTS**

Be advised, there may be an active project(s) adjacent to or within this project. The Engineer will coordinate the work of the Contractors. See Section 105.06.

1-3193 Coordination Contracts  
01/02/2012

## **SPECIAL NOTE FOR DOUBLE ASPHALT SEAL COAT**

Use RS-2 or RS-2C asphalt material that is compatible with the seal aggregate. Apply the first course of asphalt seal coat at the rate of 3.2 lbs/sy of asphalt and 30 lbs/sy of size #78 seal coat aggregate. Apply the second course at 2.8 lbs/sy of asphalt and 20 lbs/sy of size #9M seal coat aggregate. The Engineer may adjust the rate of application as conditions warrant. Use caution in applying liquid asphalt material to avoid over spray getting on curbs, gutter, barrier walls, bridges, guardrail, and other roadway appurtenances.

The Department will not measure any surface preparation required prior to applying the asphalt seal coat, but shall be incidental to “Asphalt Material for Asphalt Seal Coat”.

1-3215 Double Asphalt Seal Coat  
01/02/2012

### SPECIAL NOTE FOR EDGE KEY

---

Construct Edge Keys at the beginning of project, end of project, at railroad crossings, and at ramps, as applicable. Unless specified in the Contract or directed by the Engineer, do not construct edge keys at intersecting streets, roads, alleys, or entrances. Cut out the existing asphalt surface to the required depth and width shown on the drawing and heel the new surface into the existing surface. The Department will make payment for this work at the Contract unit price per ton for Asphalt Pavement Milling and Texturing, which shall be full compensation for all labor, materials, equipment, and incidentals for removal and disposal of the existing asphalt surface required to construct the edge key.

### EDGE KEY

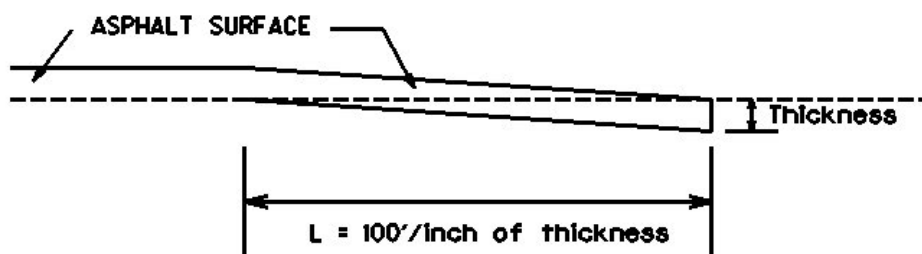

Thickness = 1.00 Inches

L = 100 LF

L= Length of Edge Key

## SPECIAL NOTES FOR GUARDRAIL

---

### I. DESCRIPTION

Except as specified herein, perform all work in accordance with the Department's Standard and Supplemental Specifications, Special Notes and Special Provisions, and the Standard and Sepia Drawings, current editions. Article references are to the Standard Specifications.

Furnish all equipment, labor, materials, and incidentals for the following work items:

(1) Site preparation; (2) Remove existing guardrail systems; (3) Construct Guardrail, End Treatments, Bridge End Connectors, and Terminal Sections, as applicable; (4) Delineators for guardrail; (5) Maintain and Control Traffic; and (6) all other work specified as part of this contract.

### II. MATERIALS

Except as specified herein, provide for all materials to be sampled and tested in accordance with the Department's Sampling Manual and make the materials available for sampling a sufficient time in advance of the use of the materials to allow for the necessary time for testing.

- A. Maintain and Control Traffic.** See Traffic Control Plan.
- B. Guardrail.** Furnish guardrail system components according to Section 814 and the Standard and Sepia Drawings; except use steel posts only, no alternates.
- C. Delineators for Guardrail.** Furnish white and/or yellow Delineators for Guardrail according to Standard Drawing RBR-055 – Delineators for Guardrail, current edition.
- D. Erosion Control.** See the Special Note for Erosion Control.

### III. CONSTRUCTION METHODS

- A. Maintain and Control Traffic.** See Traffic Control Plan.
- B. Site Preparation.** Remove existing guardrail system, including the guardrail end treatments, Bridge End connectors and all other elements of the existing guardrail system as per Section 719, except that the Contractor will take possession of all concrete posts and all concrete associated with the existing bridge and/or guardrail end treatments. Locate all disposal areas off the Right of Way. Be responsible for all site preparation, including but not limited to, clearing and grubbing, excavation, embankment, and removal of all obstructions or any other items; regrading, reshaping, adding and compacting of suitable materials on the existing shoulders to provide proper template or foundation for the guardrail;

Guardrail  
Page 2 of 3

filling voids left as the result of removing existing guardrail and guard posts with dry sand; temporary pollution and erosion control; disposal of excess, waste materials, and debris; and final dressing, cleanup, and seeding and protection. Perform all site preparation as approved or directed by the engineer.

- C. Guardrail.** Except as specified herein, construct guardrail system according to Section 719 and the Standard and Sepia Drawings, current editions. Locations listed on the summary and/or shown on the drawings are approximate only. The Engineer will determine the exact termini for individual guardrail installations at the time of construction. Unless directed otherwise by the Engineer, provide a minimum two (2) foot shoulder width. Construct radii at entrances and road intersections as directed by the Engineer.

Erect guardrail to the lines and grades shown on the current Standard and Sepia Drawings, or as directed by the Engineer by any method approved by the Engineer which allows construction of the guardrail to the true grade without apparent sags.

When removing existing guardrail and installing new guardrail, do not leave the blunt end exposed where it would be hazardous to the public. When it is not practical to complete the construction of the guardrail and the permanent end treatments and terminal sections first, provide a temporary end by connecting at least 25 feet of rail to the last post, and by slightly flaring, and burying the end of the rail completely into the existing shoulder. If left overnight, place a drum with bridge panel in advance of the guardrail end and maintain during use.

- D. Delineators for Guardrail.** Construct Delineators for Guardrail according to Standard Drawing RBR-055 – Delineators for Guardrail, current edition.
- E. Property Damage.** Be responsible for all damage to public and/or private property resulting from the work. Restore damaged roadway features and private property at no additional cost to the Department.
- F. Coordination with Utility Companies.** Locate all underground, above ground, and overhead utilities prior to beginning construction. Be responsible for contacting and maintaining liaison with all utility companies that have utilities located within the project limits. Do not disturb existing overhead or underground utilities. It is not anticipated that any utility facilities will need to be relocated and/or adjusted; however, in the event that it is discovered that the work does require utilities to be relocated and/or adjusted, the utility companies will work concurrently with the Contractor while relocating their facilities. Be responsible for repairing all utility damage that occurs as a result of guardrail operations at no additional cost to the Department.
- G. Right of Way Limits.** The Department has not established the exact limits of the Right-of-Way. Limit work activities to obvious Right-of-Way, permanent or temporary easements, and work areas secured by the Department through consent and release of the adjacent property owners. Be responsible for all encroachments onto private lands.

Guardrail  
Page 3 of 3

- H. Clean Up, Disposal of Waste.** Dispose of all removed concrete, debris, and other waste and debris off the Right-of-Way at sites obtained by the Contractor at no additional cost to the Department. See the Special Provision for Waste and Borrow Sites.
- I. Final Dressing, Seeding and Protection.** Apply Class A Final Dressing to all disturbed areas, both on and off the Right-of-Way. Sow all disturbed earthen areas with the applicable seed mixture(s) according to Section 212.03.03.
- J. Erosion Control.** See the Special Note for Erosion Control.

**IV. METHOD OF MEASUREMENT**

- A. Maintain and Control Traffic.** See Traffic Control Plan.
- B. Site preparation.** Other than the bid items listed, the Department will not measure Site Preparation for separate payment but shall be incidental to the Guardrail, End Treatments, Bridge End Connectors, and Terminal Sections, as applicable.
- C. Guardrail, End Treatments, Bridge End Connectors, Terminal Sections, and Remove Guardrail.** The Department will measure according to Section 719.04.
- D. Delineators for Guardrail.** See Standard Drawing RBR-055 – Delineators for Guardrail.
- E. Clean Up, Disposal of Waste, Final Dressing, and Seeding and Protection.** The Department will NOT measure for payment the operations of: Clean Up, Disposal of Waste, and Final Dressing. These activities shall be incidental. Seeding and Protection will be measured according to Section 212.
- F. Erosion Control.** See the Special Note for Erosion Control.

**V. BASIS OF PAYMENT**

- A. Maintain and Control Traffic.** See Traffic Control Plan.
- B. Guardrail, End Treatments, Bridge End Connectors, Terminal Sections, and Remove Guardrail.** The Department will make payment according to Section 719.05.
- C. Delineators for Guardrail.** See Standard Drawing RBR-055 – Delineators for Guardrail.
- D. Erosion Control.** See the Special Note for Erosion Control.

**SPECIAL NOTE FOR  
ASPHALT MILLING AND TEXTURING**

Begin paving operations within **48 hours** of commencement of the milling operation. Continue paving operations continuously until completed. If paving operations are not begun within this time period, the Department will assess liquidated damages at the rate prescribed by Section 108.09 until such time as paving operations are begun.

Take possession of the millings and recycle the millings or dispose of the millings off the Right-of-Way at sites obtained by the Contractor at no additional cost to the Department.

1-3520 48 hours Contractor keeps millings  
01/2/2012

## SPECIAL NOTES FOR BASE FAILURE REPAIR

---

Repair locations listed on the summary are approximate only. The Engineer will determine actual repair locations and dimensions at the time of construction. Prior to milling and/or resurfacing, saw cut the existing pavement, asphalt surface, base, DGA, and PCC pavement (if present). Excavate to an approximate depth of 20 inches below the existing pavement surface level. Use all possible care to avoid damaging existing culvert pipes and any existing underground utilities. Repair or restore any damaged items at no additional cost to the Department. Waste all removed materials off the Right of Way at sites obtained by the Contractor at no additional cost to the Department. See the Special Provision for Waste and Borrow Sites.

On the same day trench is excavated, backfill the excavated area with 12 inches of Crushed Limestone Size No. 23, wrapped on the bottom and sides in Class 2 Geotextile Fabric, and 8 inches of Class 2 Asphalt Base 1.00D PG64-22, in 4 inch maximum courses, up to the existing pavement surface. Compact the asphalt base to the proper compaction as required by Section 403. Seal the asphalt base with leveling and wedging. Perform all base failure repairs in such a manner that removal and replacement are completed on the same day. Do this work as one of the Contractor's first operations in order to allow further compaction by traffic. Do not mill or place new asphalt surface over repaired base failure areas until a minimum of 14 calendar days have elapsed after placement of the final course of asphalt base. After the 14 calendar day waiting period, and/or when the Engineer determines the base failure repair areas have sufficiently stabilized, begin milling and/or resurfacing operations. Prior to milling and/or constructing the new asphalt surface, level and wedge any settlement of the repair areas.

The bidder must draw his or her own conclusions as to the conditions to be encountered. The Department does not give any guarantee as to the accuracy of the data and no claim will be considered for additional compensation of the materials encountered that are not in accord with the classification shown.

Accept payment at the Contract unit prices per square yard for Base Failure Repair and per ton for Leveling and Wedging as full compensation for all labor, materials, equipment, and incidentals for saw cutting pavement and excavating and disposing of all materials; furnishing and placing crushed limestone stone wrapped in geotextile fabric; furnishing and placing asphalt base up to the pavement boundary; leveling and wedging until the repair areas stabilize; and all other items necessary to complete the work according to these notes to the satisfaction of the Engineer.

### **SPECIAL NOTE FOR TYPICAL SECTION DIMENSIONS**

Consider the dimensions shown on the typical sections for pavement and shoulder widths and thickness' to be nominal or typical dimensions. The Engineer may direct or approve varying the actual dimensions to be constructed to fit existing conditions. Do not widen existing pavement or shoulders unless specified elsewhere in this proposal or directed by the engineer.

1-3725 Typical Section Dimensions  
01/02/2012

## **TRAFFIC CONTROL PLAN ITEM NO. 2-9009.00**

---

### **TRAFFIC CONTROL GENERAL**

Except for the roadway and traffic control bid items listed, all items of work necessary to maintain and control traffic will be paid at the lump sum bid price to “Maintain and Control Traffic” in accordance with the current editions of the Manual on Uniform Traffic Control Devices (MUTCD), Standard and Supplemental Specifications, and Standard and Sepia Drawings. The lump sum bid price to “Maintain and Control Traffic” shall include, but is not limited to, the following items and operations:

- A. All labor and materials necessary for construction and maintenance of traffic control devices and markings.
- B. All flag persons and traffic control devices such as, but not limited to, flashers, signs, barricades and vertical panes, plastic drums (steel drums will not be permitted), and cones, necessary for the control and protection of vehicular and pedestrian traffic as specified in these notes, the proposal, the Manual on Uniform Traffic Control Devices (MUTCD) current condition, or the Engineer.

Contrary to Section 106.01, traffic control devices used on this project may be new, or used in like new condition, at the beginning of the work and maintained in like new condition until completion of the work. Any temporary traffic control items, devices, materials, and incidentals shall remain the property of the Contractor when no longer needed.

Maintain access to all entrances, side streets and roads, churches and commercial properties at all times during construction. Access to fire hydrants must also be maintained at all times. The Contractor will be responsible to notify adjacent property owners when work affecting the entrances will be performed.

### **PROJECT PHASING & CONSTRUCTION PROCEDURES**

Maintain alternating one way traffic during construction. Provide a minimum clear lane width of 10 feet; however, provide for passage of vehicles of up to 16 feet in width. If traffic should be stopped due to construction operations, and a school bus or emergency vehicle on an official run arrives on the scene, make provisions for the passage of the school bus or emergency vehicle as quickly as possible.

The Contractor shall submit proposed days of lane closures to the Engineer at least 14 calendar days in advance for approval.

Unless otherwise approved by the Engineer, no lane closures will be allowed on the following dates:

Thanksgiving Weekend                      Thursday, November 26, 2020 – Sunday, November 29, 2020

Traffic Control Plan  
Page 2 of 9

Christmas	Wednesday, December 23, 2020 – Friday, December 25, 2020
New Year's	Wednesday, December 30, 2020 – Friday, January 1, 2021
Easter Weekend	Friday, April 2, 2021 – Sunday, April 4, 2021
Memorial Day Weekend	Friday, May 28, 2021 – Monday, May 31, 2021
Independence Day Weekend	Friday, July 2, 2021 – Monday, July 5, 2021

The Engineer may specify additional days and/or hours when lane closures will not be allowed due to unforeseen events.

Liquidated Damages will be assessed for any and all lane closures that exceed the approval time limits in accordance with the Special Note for Completion Dates & Liquidated Damages.

The Contractor shall completely cover any signs, existing, permanent, or temporary, which do not properly apply to the current traffic phasing, and shall maintain the covering until signs are applicable or are removed.

In general, all traffic control devices shall be placed starting and proceeding in the direction of the flow of traffic, and removed starting and proceeding in the direction opposite the flow of traffic.

### **LANE AND SHOULDER CLOSURES**

No long term lane closures (more than 3 days) will be allowed; therefore, lane closures will not be measured for payment. Do not leave lane closures in place during non-work hours and prohibited periods, unless otherwise approved by the Engineer.

### **SIGNS**

The Engineer and the Contractor, or their authorized representative, shall review the signing before traffic is allowed to use any lane closures, crossovers, or detours. All signing shall be approved by the Engineer before work can be started by the Contractor.

Sign posts and splices shall be compliant with NCHRP 350 or MASH. Manufacturer's documentation validating this compliance shall be provided to the Engineer prior to installation. Signs, including any splices, shall be installed according to manufacturer's specifications and installation recommendations. Contrary to Section 112.04.02, only long-term signs (signs intended to be continuously in place for more than 3 days) will be measured for payment. Short-term signs (signs intended to be left in place for 3 days or less) will not be measured for payment but will be incidental to Maintain and Control Traffic. Individual signs will be measured only once for payment, regardless of how many times they are set, reset, relocated, and removed during the duration of the project. Replacements for damaged signs directed by the Engineer to be replaced due to poor condition or reflectivity will not be measured for payment.

### **CHANGEABLE MESSAGE SIGNS**

Provide Portable Changeable Message Sign (PCMS) at least two weeks prior to construction at the locations approved by the Engineer. The messages required to be provided will be designated by the

## Traffic Control Plan Page 3 of 9

Engineer. The PCMS will be in operation at all times. In the event of damage or mechanical/ electrical failure, the Contractor will repair or replace the PCMS immediately. The Department will not take possession of the signs upon completion of the work. The Department will measure for payment the maximum number of PCMS in concurrent use at the same time on a single day on all sections of the contract. PCMS will be paid for once, regardless of how many times they are set, reset, removed, and relocated during the duration of the project. The Department will not measure for payment replacements for damaged PCMS or for signs the Engineer directs be replaced due to poor condition or readability.

### **BARRICADES**

The Department will not measure barricades used in lieu of barrels and cones for channelization or delineation, but shall be incidental to Maintain and Control Traffic according to Section 112.04.01.

The Department will measure barricades used for road closures and to protect pavement removal areas in individual units Each. The Department will measure for payment the maximum number of barricades in concurrent use at the same time on a single day on all sections of the contract. The Department will measure individual barricades only once for payment, regardless of how many times they are set, reset, removed, and relocated during the duration of the project. The Department will not measure replacements for damaged barricades the Engineer directs to be replaced due to poor condition or reflectivity. The Contractor shall retain possession of the barricades upon completion of construction.

### **PAVEMENT MARKINGS**

Removal of pavement markings will be by water blasting process to the satisfaction of the Engineer. Pavement markings proposed in the Plan, Detail, and Summary sheets shall be placed as proposed and located as specified in those sheets.

If there is to be a deviation from the existing striping plan, the Engineer will furnish the Contractor a striping plan prior to placement of the final surface course. Install Temporary Striping according to Section 112 with the following exception:

If the Contractor's operations or phasing requires temporary markings that must subsequently be removed from the final surface course, use an approved removable lane tape; however, the Department will not measure removable lane tape for separate payment, but will measure and pay for removable lane tape as temporary striping.

### **PAVEMENT EDGE DROP-OFFS**

Do not allow a pavement edge between opposing directions of traffic or lanes that traffic is expected to cross in a lane change situation with an elevation difference greater than 1½". Place warning signs (MUTCD W8-11 or W8-9A) in advance of and at 1500' intervals throughout the drop-off area. Dual-post the signs on both sides of the traveled way. Wedge all transverse transitions between resurfaced and un-resurfaced areas which traffic may cross with asphalt mixture for leveling and wedging. Remove the wedges prior to placement of the final surface course.

Traffic Control Plan  
Page 4 of 9

Protect pavement edges that traffic is not expected to cross, except inadvertently, as follows:

Less than 2" - No protection required.

2" to 4" - Place plastic drums, vertical panels, or barricades every 50 feet. During daylight working hours only, the Engineer will allow the Contractor to use cones in lieu of plastic drums, panels, and barricades. Spacing of devices on tapered sections shall be in accordance with MUTCD, current edition. When work is not active in the drop-off area, wedge the drop-off with DGA or asphalt mixture for leveling and wedging with a 1:1 or flatter slope in daylight hours, or 3:1 or flatter slope during nighttime hours.

Greater than 4" - Protect drop-offs greater than 4" by placing drums, vertical panels, or barricades between the edge of pavement and drop-off. The Engineer will not allow the use of cones in lieu of drums, vertical panels, or barricades. If concrete barriers are used, special reflective devices or steady burn lights should be used for overnight installations.

## **USE AND PLACEMENT OF CHANGEABLE MESSAGE SIGNS**

The following policy is based upon current Changeable Message Signs (CMS) standards and practice from many sources, including the Federal Highway Administration (FHWA), other State Departments of Transportation, and Traffic Safety Associations. It is understood that each CMS installation or use requires individual consideration due to the specific location or purpose. However, there will be elements that are constant in nearly all applications. Accordingly these recommended guidelines bring a level of uniformity, while still being open to regional experience and engineering judgment.

### **Application**

The primary purpose of CMS is to advise the driver of unexpected traffic and routing situations. Examples of applications where CMS can be effective include:

- Closures (road, lane, bridge, ramp, shoulder, interstate)
- Changes in alignment or surface conditions
- Significant delays, congestion
- Construction/maintenance activities (delays, future activities)
- Detours/alternative routes
- Special events with traffic and safety implications
- Crash/incidents
- Vehicle restrictions (width, height, weight, flammable)
- Advance notice of new traffic control devices
- Real-time traffic conditions (must be kept up to date)
- Weather /driving conditions, environmental conditions, Roadway Weather Information Systems

Traffic Control Plan  
Page 5 of 9

**Application** (cont)

- Emergency Situations
- Referral to Highway Advisory Radio (if available)
- Messages as approved by the County Engineer's Office

**CMS should not be used for:**

- Replacement of static signs (e.g. road work ahead), regulatory signage (e.g. speed limits), pavement markings, standard traffic control devices, conventional warning or guide signs.
- Replacement of lighted arrow board
- Advertising (Don't advertise the event unless clarifying "action" to be taken by driver – e.g. Speedway traffic next exit)
- Generic messages
- Test messages (portable signs only)
- Describe recurrent congestion (e.g. rush hour)
- Public service announcements (not traffic related)

**Messages**

Basic principles that are important to providing proper messages and insuring the proper operation of a CMS are:

- Visible for at least ½ mile under ideal daytime and nighttime conditions
- Legible from all lanes a minimum of 650 feet
- Entire message readable twice while traveling at the posted speed
- No more than two message panels should be used (three panels may be used on roadways where vehicles are traveling less than 45 mph). A panel is the message that fits on the face of the sign without flipping or scrolling.
- Each panel should convey a single thought; short and concise
- Do not use two unrelated panels on a sign
- Do not use the sign for two unrelated messages
- Should not scroll text horizontally or vertically
- Should not contain both the words left and right
- Use standardized abbreviations and messages
- Should be accurate and timely
- Avoid filler/unnecessary words and periods (hazardous, a, an, the)
- Avoid use of speed limits
- Use words (not numbers) for dates

**Placement**

Placement of the CMS is important to insure that the sign is visible to the driver and provides ample time to take any necessary action. Some of the following principles may only be applicable to controlled access roadways. The basic principles of placement for a CMS are:

- When 2 signs are needed, place on same side of roadway and at least 1,000 feet apart

Traffic Control Plan  
Page 6 of 9

**Placement** (cont)

- Place behind semi-rigid/rigid protection (guardrail, barrier) or outside of the clear zone
- Place 1,000 feet in advance of work zone; at least one mile ahead of decision point
- Normally place on right side of roadway; but should be placed closest to the affected lane so that either side is acceptable
- Signs should not be dual mounted (one on each side of roadway facing same direction)
- Point trailer hitch downstream
- Secure to immovable object to prevent theft (if necessary)
- Do not place in sags or just beyond crest
- Check for reflection of sun to prevent the blinding of motorist
- Should be turned ~3 degrees outward from perpendicular to the edge of pavement
- Bottom of sign should be 7 feet above the elevation of edge of roadway
- Should be removed when not in use

**Standard Abbreviations**

The following is a list of standard abbreviations to be used on CMS:

<b><u>Word</u></b>	<b><u>Abbrev</u></b>	<b><u>Example</u></b>
Access	ACCS	ACCIDENT AHEAD/ USE ACCS RD NEXT RIGHT
Alternate	ALT	ACCIDENT AHEAD/ USE ALT RTE NEXT RIGHT
Avenue	AVE	FIFTH AVE CLOSED/ DETOUR NEXT LEFT
Blocked	BLKD	FIFTH AVE BLKD/ MERGE LEFT
Boulevard	BLVD	MAIN BLVD CLOSED/ USE ALT RTE
Bridge	BRDG	SMITH BRDG CLOSED/ USE ALT RTE
Cardinal Directions	N, S, E, W	N I75 CLOSED/ DETOUR EXIT 30
Center	CNTR	CNTR LANE CLOSED/ MERGE LEFT
Commercial	COMM	OVRSZ COMM VEH/ USE I275
Condition	COND	ICY COND POSSIBLE
Congested	CONG	HVY CONG NEXT 3 MI
Construction	CONST	CONST WORK AHEAD/ EXPECT DELAYS
Downtown	DWNTN	DWNTN TRAF USE EX 40
Eastbound	E-BND	E-BND I64 CLOSED/ DETOUR EXIT 20
Emergency	EMER	EMER VEH AHEAD/ PREPARE TO STOP
Entrance, Enter	EX, EXT	DWNTN TRAF USE EX 40
Expressway	EXPWY	WTRSN EXPWY CLOSED/ DETOUR EXIT 10
Freeway	FRWY, FWY	GN SYNDR FWY CLOSED/ DETOUR EXIT 15
Hazardous Materials	HAZMAT	HAZMAT IN ROADWAY/ ALL TRAF EXIT 25
Highway	HWY	ACCIDENT ON AA HWY/ EXPECT DELAYS
Hour	HR	ACCIDENT ON AA HWY/ 2 HR DELAY
Information	INFO	TRAF INFO TUNE TO 1240 AM
Interstate	I	E-BND I64 CLOSED/ DETOUR EXIT 20
Lane	LN	LN CLOSED MERGE LEFT
Left	LFT	LANE CLOSED MERGE LFT
Local	LOC	LOC TRAF USE ALT RTE
Maintenance	MAINT	MAINT WRK ON BRDG/ SLOW
Major	MAJ	MAJ DELAYS I75/ USE ALT RTE
Mile	MI	ACCIDENT 3 MI AHEAD/ USE ALT RTE

Traffic Control Plan  
Page 7 of 9

**Standard Abbreviations** (cont)

<b><u>Word</u></b>	<b><u>Abbrev</u></b>	<b><u>Example</u></b>
Minor	MNR	ACCIDENT 3 MI MNR DELAY
Minutes	MIN	ACCIDENT 3 MI/ 30 MIN DELAY
Northbound	N-BND	N-BND I75 CLOSED/ DETOUR EXIT 50
Oversized	OVRSZ	OVRSZ COMM VEH/ USE I275 NEXT RIGHT
Parking	PKING	EVENT PKING NEXT RGT
Parkway	PKWY	CUM PKWAY TRAF/ DETOUR EXIT 60
Prepare	PREP	ACCIDENT 3 MI/ PREP TO STOP
Right	RGT	EVENT PKING NEXT RGT
Road	RD	HAZMAT IN RD/ ALL TRAF EXIT 25
Roadwork	RDWK	RDWK NEXT 4 MI/ POSSIBLE DELAYS
Route	RTE	MAJ DELAYS I75/ USE ALT RTE
Shoulder	SHLDR	SHLDR CLOSED NEXT 5 MI
Slippery	SLIP	SLIP COND POSSIBLE/ SLOW SPD
Southbound	S-BND	S-BND I75 CLOSED/ DETOUR EXIT 50
Speed	SPD	SLIP COND POSSIBLE/ SLOW SPD
Street	ST	MAIN ST CLOSED/ USE ALT RTE
Traffic	TRAF	CUM PKWAY TRAF/ DETOUR EXIT 60
Vehicle	VEH	OVRSZ COMM VEH/ USE I275 NEXT RIGHT
Westbound	W-BND	W-BND I64 CLOSED/ DETOUR EXIT 50
Work	WRK	CONST WRK 2MI/ POSSIBLE DELAYS

Certain abbreviations are prone to inviting confusion because another word is abbreviated or could be abbreviated in the same way. DO NO USE THESE ABBREVIATIONS:

<b><u>Abbrev</u></b>	<b><u>Intended Word</u></b>	<b><u>Word Erroneously Given</u></b>
ACC	Accident	Access (Road)
CLRS	Clears	Colors
DLY	Delay	Daily
FDR	Feeder	Federal
L	Left	Lane (merge)
LOC	Local	Location
LT	Light (traffic)	Left
PARK	Parking	Park
POLL	Pollution (index)	Poll
RED	Reduce	Red
STAD	Stadium	Standard
TEMP	Temporary	Temperature
WRNG	Warning	Wrong

**Typical Messages**

The following is a list of typical messages used on CMS. The list consists of the reason or problem that you want the driver to be aware of and the action that you want the driver to take.

<b><u>Reason/Problem</u></b>	<b><u>Action</u></b>
ACCIDENT	ALL TRAFFIC EXIT RT
ACCIDENT/XX MILES	AVOID DELAY USE XX
XX ROAD CLOSED	CONSIDER ALT ROUTE

Traffic Control Plan  
Page 8 of 9

**Typical Messages** (cont)

**Reason/Problem**

XX EXIT CLOSED  
BRIDGE CLOSED  
BRIDGE/(SLIPPERY, ICE, ETC.)  
CENTER/LANE/CLOSED  
DELAY(S), MAJOR/DELAYS  
DEBRIS AHEAD  
DENSE FOG  
DISABLED/VEHICLE  
EMER/VEHICLES/ONLY  
EVENT PARKING  
EXIT XX CLOSED  
FLAGGER XX MILES  
FOG XX MILES  
FREEWAY CLOSED  
FRESH OIL  
HAZMAT SPILL  
ICE  
INCIDENT AHEAD  
LANES (NARROW, SHIFT, MERGE, ETC.)  
LEFT LANE CLOSED  
LEFT LANE NARROWS  
LEFT 2 LANES CLOSED  
LEFT SHOULDER CLOSED  
LOOSE GRAVEL  
MEDIAN WORK XX MILES  
MOVING WORK ZONE, WORKERS IN ROADWAY  
NEXT EXIT CLOSED  
NO OVERSIZED LOADS  
NO PASSING  
NO SHOULDER  
ONE LANE BRIDGE  
PEOPLE CROSSING  
RAMP CLOSED  
RAMP (SLIPPERY, ICE, ETC.)  
RIGHT LANE CLOSED  
RIGHT LANE NARROWS  
RIGHT SHOULDER CLOSED  
ROAD CLOSED  
ROAD CLOSED XX MILES  
ROAD (SLIPPERY, ICE, ETC.)  
ROAD WORK  
ROAD WORK (OR CONSTRUCTION) (TONIGHT, TODAY, TOMORROW, DATE)  
ROAD WORK XX MILES  
SHOULDER (SLIPPERY, ICE, SOFT, BLOCKED, ETC.)  
NEW SIGNAL XX MILES  
SLOW 1 (OR 2) - WAY TRAFFIC  
SOFT SHOULDER  
STALLED VEHICLES AHEAD

**Action**

DETOUR  
DETOUR XX MILES  
DO NOT PASS  
EXPECT DELAYS  
FOLLOW ALT ROUTE  
KEEP LEFT  
KEEP RIGHT  
MERGE XX MILES  
MERGE LEFT  
MERGE RIGHT  
ONE-WAY TRAFFIC  
PASS TO LEFT  
PASS TO RIGHT  
PREPARE TO STOP  
REDUCE SPEED  
SLOW  
SLOW DOWN  
STAY IN LANE  
STOP AHEAD  
STOP XX MILES  
TUNE RADIO 1610 AM  
USE NN ROAD  
USE CENTER LANE  
USE DETOUR ROUTE  
USE LEFT TURN LANE  
USE NEXT EXIT  
USE RIGHT LANE  
WATCH FOR FLAGGER

Traffic Control Plan  
Page 9 of 9

**Typical Messages** (cont)

**Reason/Problem**

TRAFFIC BACKUP  
TRAFFIC SLOWS  
TRUCK CROSSING  
TRUCKS ENTERING  
TOW TRUCK AHEAD  
UNEVEN LANES  
WATER ON ROAD  
WET PAINT  
WORK ZONE XX MILES  
WORKERS AHEAD

**DURABLE PAVEMENT EDGE DETAIL**  
(Resurfacing adjacent to fill slope or ditch foreslope that is 3:1 or less)

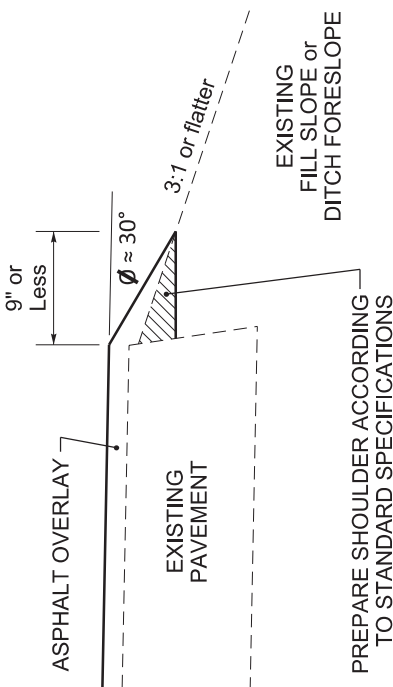

**DURABLE PAVEMENT EDGE DETAIL**  
(Resurfacing adjacent to fill slope or ditch foreslope that is steeper than 3:1)

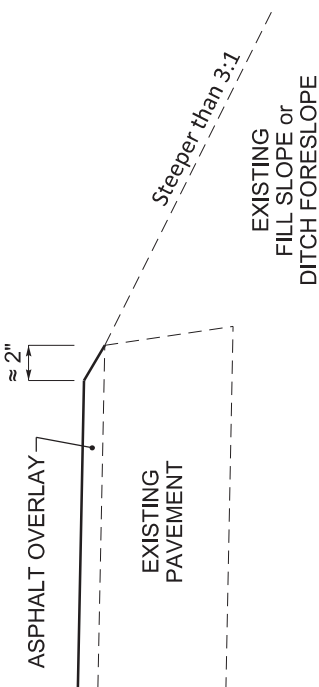

**DURABLE PAVEMENT EDGE DETAIL**  
(Resurfacing adjacent to low shoulder with dropoff of 5 inches or less)

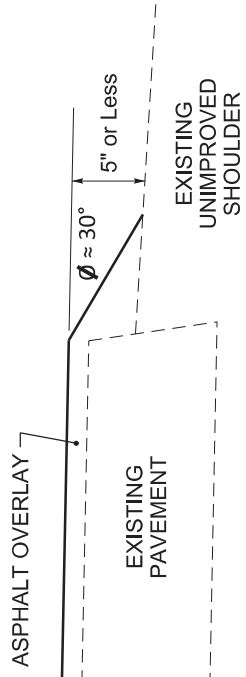

**DURABLE PAVEMENT EDGE DETAIL**  
(Resurfacing adjacent to low shoulder with dropoff of more than 5 inches)

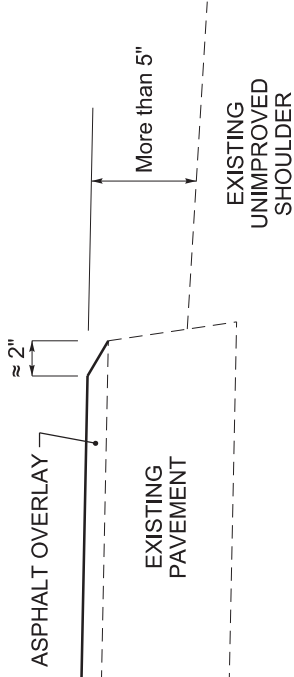

**DURABLE PAVEMENT EDGE DETAIL**  
(Resurfacing adjacent to an obstruction, such as an existing headwall)

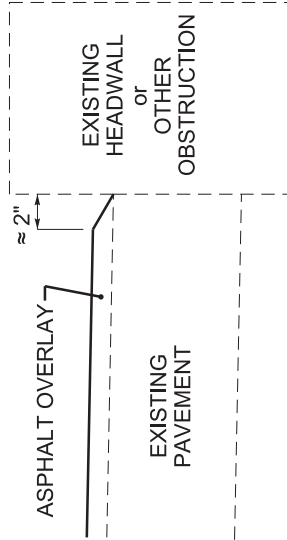

**NOTES**

1. DETAILS DO NOT APPLY TO OVERLAYS LESS THAN 1 INCH THICK.
2. THE DURABLE PAVEMENT EDGE DEVICE MAY BE DISENGAGED AT DRIVEWAYS, SIDE STREETS, HIGH SHOULDERS, AND OTHER LOCATIONS NOT FEASIBLE TO CONSTRUCT, AS APPROVED BY THE ENGINEER.

DRAWING NOT TO SCALE

DURABLE PAVEMENT EDGE DETAILS

	KENTUCKY TRANSPORTATION CABINET Department of Highways DIVISION OF RIGHT OF WAY & UTILITIES  <b>RIGHT OF WAY CERTIFICATION</b>	TC 62-226 Rev. 01/2016 Page 1 of 1
---	--	--

<input type="checkbox"/> Original	<input checked="" type="checkbox"/> Re-Certification	<b>RIGHT OF WAY CERTIFICATION</b>	
ITEM #	COUNTY	PROJECT # (STATE)	PROJECT # (FEDERAL)
2-9009.00	Union	FD52 113 0130 009-016	HSIP 5049 (006)

**PROJECT DESCRIPTION**

Perform low cost safety improvements along KY 130 between MP 9.584 and MP 15.657 in Union County, KY.

**No Additional Right of Way Required**

Construction will be within the limits of the existing right of way. The right of way was acquired in accordance to FHWA regulations under the Uniform Relocation Assistance and Real Property Acquisitions Policy Act of 1970, as amended. No additional right of way or relocation assistance were required for this project.

**Condition # 1 (Additional Right of Way Required and Cleared)**

All necessary right of way, including control of access rights when applicable, have been acquired including legal and physical possession. Trial or appeal of cases may be pending in court but legal possession has been obtained. There may be some improvements remaining on the right-of-way, but all occupants have vacated the lands and improvements, and KYTC has physical possession and the rights to remove, salvage, or demolish all improvements and enter on all land. Just Compensation has been paid or deposited with the court. All relocations have been relocated to decent, safe, and sanitary housing or that KYTC has made available to displaced persons adequate replacement housing in accordance with the provisions of the current FHWA directive.

**Condition # 2 (Additional Right of Way Required with Exception)**



The right of way has not been fully acquired, the right to occupy and to use all rights-of-way required for the proper execution of the project has been acquired. Some parcels may be pending in court and on other parcels full legal possession has not been obtained, but right of entry has been obtained, the occupants of all lands and improvements have vacated, and KYTC has physical possession and right to remove, salvage, or demolish all improvements. Just Compensation has been paid or deposited with the court for most parcels. Just Compensation for all pending parcels will be paid or deposited with the court prior to AWARD of construction contract

**Condition # 3 (Additional Right of Way Required with Exception)**

The acquisition or right of occupancy and use of a few remaining parcels are not complete and/or some parcels still have occupants. All remaining occupants have had replacement housing made available to them in accordance with 49 CFR 24.204. KYTC is hereby requesting authorization to advertise this project for bids and to proceed with bid letting even though the necessary right of way will not be fully acquired, and/or some occupants will not be relocated, and/or the just compensation will not be paid or deposited with the court for some parcels until after bid letting. KYTC will fully meet all the requirements outlined in 23 CFR 635.309(c)(3) and 49 CFR 24.102(j) and will expedite completion of all acquisitions, relocations, and full payments after bid letting and prior to AWARD of the construction contract or force account construction.

Total Number of Parcels on Project	0	EXCEPTION (S) Parcel #	ANTICIPATED DATE OF POSSESSION WITH EXPLANATION
<b>Number of Parcels That Have Been Acquired</b>			
Signed Deed			
Condemnation			
Signed ROE			

**Notes/ Comments (Use Additional Sheet if necessary)**

LPA RW Project Manager		Right of Way Supervisor	
Printed Name		Printed Name	Jennifer K Cox
Signature		Signature	 2020.07.22 12:49:57
Date		Date	-05'00'
Right of Way Director		FHWA	
Printed Name		Printed Name	No Signature Required
Signature	 2020.07.23	Signature	as per FHWA-KYTC
Date	07:37:38 -05'00'	Date	Current Stewardship Agreement

## UTILITIES AND RAIL CERTIFICATION NOTE

**Union County - HSIP 5049 (006)**  
**FD52 625 1550 113-143**  
**KY 130 Corridor Safety Improvements**  
**Item No. 2-9009.00**

**GENERAL PROJECT NOTE ON UTILITY PROTECTION**

*Utility coordination efforts determined that no significant utility relocation work is required to complete the project.*

**NOTE: DO NOT DISTURB THE FOLLOWING UTILITIES LOCATED WITHIN THE PROJECT DISTURB LIMITS**

**City of Morganfield**

Steel gas line, along the east side from beginning to approx. STA. 563+00 before crossing the roadway and continuing along the west side of the roadway for the remainder of the corridor.

**Union County Water District**

PVC waterline, along the west side from beginning to approx. STA. 563+00.  
PVC waterline, along the east side from approx. STA. 583+00 to approx. STA. 670+00 before crossing the roadway and continuing along the west side until the intersection with KY 141.  
PVC waterline, along the east side from the intersection with KY 141 to a water meter pit at approx. STA 752+75.

**City of Uniontown**

PVC waterline, along the east side from the water meter pit at approx. STA 752+75 for the remainder of the corridor.

**AT&T/LGE-KU/Windstream**

Overhead lines, along the corridor.

**Alliance Coal**

Overhead transmission belt, transverse to the road at approx. STA. 771+50.

**LGE-KU**

Underground lines, along the east side at the Alliance Coal Transmission Belt.

**\*The Contractor is fully responsible for protection of all utilities listed above\***

**THE FOLLOWING COMPANIES ARE RELOCATING/ADJUSTING THEIR UTILITIES WITHIN THE PROJECT LIMITS AND WILL BE COMPLETE PRIOR TO CONSTRUCTION**

None

**THE FOLLOWING COMPANIES HAVE FACILITIES TO BE RELOCATED/ADJUSTED BY THE COMPANY OR THE COMPANY'S SUBCONTRACTOR AND IS TO BE COORDINATED WITH THE ROAD CONTRACT**

None

## UTILITIES AND RAIL CERTIFICATION NOTE

**Union County - HSIP 5049 (006)  
FD52 625 1550 113-143  
KY 130 Corridor Safety Improvements  
Item No. 2-9009.00**

**THE FOLLOWING COMPANIES HAVE FACILITIES TO BE RELOCATED/ADJUSTED BY THE ROAD CONTRACTOR AS INCLUDED IN THIS CONTRACT**

None

**THE FOLLOWING RAIL COMPANIES HAVE FACILITIES IN CONJUNCTION WITH THIS PROJECT AS NOTED**

No Rail Involved       Minimal Rail Involved (See Below)       Rail Involved (See Below)

## UTILITIES AND RAIL CERTIFICATION NOTE

**Union County - HSIP 5049 (006)**  
**FD52 625 1550 113-143**  
**KY 130 Corridor Safety Improvements**  
**Item No. 2-9009.00**

### **UNDERGROUND FACILITY DAMAGE PROTECTION – BEFORE YOU DIG**

The Contractor shall make every effort to protect underground facilities from damage as prescribed in the Underground Facility Damage Protection Act of 1994, Kentucky Revised Statute KRS 367.4901 to 367.4917. It is the Contractor's responsibility to determine and take steps necessary to be in compliance with federal and state damage prevention directives. The Contractor is instructed to contact KY 811 for the location of existing underground utilities. Contact shall be made a minimum of two (2) and no more than ten (10) business days prior to excavation.

The Contractor shall submit Excavation Locate Requests to the Kentucky Contact Center (KY 811) via web ticket entry. The submission of this request does not relieve the Contractor from the responsibility of contacting non-member facility owners, whom are to be contacted through their individual Protection Notification Center. It may be necessary for the Contractor to contact the County Court Clerk to determine what utility companies have facilities in the area. Non-compliance with these directives can result in the enforcement of penalties.

### **SPECIAL CAUTION NOTE – PROTECTION OF UTILITIES**

The Contractor will be responsible for contacting all utility facility owners on the subject project to coordinate his activities. The Contractor will coordinate his activities to minimize and, where possible, avoid conflicts with utility facilities. Due to the nature of the work proposed, it is unlikely to conflict with the existing utilities beyond minor facility adjustments. Where conflicts with utility facilities are unavoidable, the Contractor will coordinate any necessary relocation work with the facility owner and Resident Engineer. The Kentucky Transportation Cabinet maintains the right to remove or alter portions of this contract if a utility conflict occurs.

The utility facilities as noted in the previous section(s) have been determined using data garnered by varied means and with varying degrees of accuracy: from the facility owners, a result of S.U.E., field inspections, and/or reviews of record drawings. The facilities defined may not be inclusive of all utilities in the project scope and are not Level A quality, unless specified as such. It is the Contractor's responsibility to verify all utilities and their respective locations before excavating.

***Please Note: The information presented in this Utility Note is informational in nature and the information contained herein is not guaranteed.***

## UTILITIES AND RAIL CERTIFICATION NOTE

**Union County - HSIP 5049 (006)**  
**FD52 625 1550 113-143**  
**KY 130 Corridor Safety Improvements**  
**Item No. 2-9009.00**

### AREA UTILITIES CONTACT LIST

<u>Utility Company/Agency</u>	<u>Contact Name</u>	<u>Contact Information</u>
1. City of Morganfield 526 N Court St Morganfield, KY 42437	Les Piper Lpiper8215@yahoo.com	(270) 389-2524 (O) (270) 952-0477 (M)
2. Union County Water District 409 N Court St Morganfield, KY 42437	Gary Sheffer ucwdgarysheffer@yahoo.com	(270) 389-3868 (O) (270) 952-1716 (M)
3. LGE & KU	David Young david.young2@lge-ku.com	(270) 625-1872
4. City of Uniontown 237 Upper Main St Uniontown, KY 42461		(270) 822-4233
5. Windstream		
6. AT&T		
7. Alliance Coal		

***NOTE: The Utilities Contact List is provided as informational only, and may not be a complete list of all Utility Companies with facilities in the project area.***

KYTC BMP Plan for Project CID 20-4410



**Kentucky Transportation Cabinet**

**Highway District 2**

**And**

**\_\_\_\_\_ (2), Construction**

**Kentucky Pollutant Discharge Elimination System  
Permit KYR10**

**Best Management Practices (BMP) plan**

**Groundwater protection plan**

**For Highway Construction Activities**

**For**

**Highway Safety Improvement Project on KY 130 in  
Union County**

**Project: CID 20-4410**

## KYTC BMP Plan for Project CID 20-4410

### Project information

Note – (1) = Design (2) = Construction (3) = Contractor

1. Owner – Kentucky Transportation Cabinet, District 2
2. Resident Engineer: (2)
3. Contractor name: (2)  
Address: (2)  
  
Phone number: (2)  
Contact: (2)  
Contractors agent responsible for compliance with the KPDES permit requirements (3):
4. Project Control Number: (2)
5. Route (Address): KY 130
6. Latitude/Longitude (project mid-point): 37° 43' 42.6", -87° 55' 15.5"
7. County (project mid-point): Union
8. Project start date (date work will begin): (2)
9. Projected completion date: (2)

## KYTC BMP Plan for Project CID 20-4410

### A. Site description:

1. Nature of Construction Activity (from letting project description): Asphalt Pavement & Roadway Rehab
2. Order of major soil disturbing activities: (2) and (3)
3. Projected volume of material to be moved: *This project does not involve significant cut and fill.*
4. Estimate of total project area (acres): 37.9
5. Estimate of area to be disturbed (acres): 17.9
6. Post construction runoff coefficient will be included in the project drainage folder. Persons needing information pertaining to the runoff coefficient will contact the Resident engineer to request this information.
7. Data describing existing soil condition: (1) & (2)
8. Data describing existing discharge water quality (if any): (1) & (2)
9. Receiving water name: Lost Creek
10. TMDLs and Pollutants of Concern in Receiving Waters: *No TDML's were involved on this project.*
11. Site map – Project layout sheet plus the erosion control sheets in the project plans that depict Disturbed Drainage Areas (DDAs) and related information. These sheets depict the existing project conditions with areas delineated by DDA (drainage area bounded by watershed breaks and right of way limits), the storm water discharge locations (either as a point discharge or as overland flow) and the areas that drain to each discharge point. These plans define the limits of areas to be disturbed and the location of control measures. Controls will be either site specific as designated by the designer or will be annotated by the Contractor and Resident engineer before disturbance commences. The project layout sheet shows the surface waters and wetlands.
12. Potential sources of pollutants:  
  
The primary source of pollutants is solids that are mobilized during storm events. Other sources of pollutants include oil/fuel/grease from servicing and operating construction equipment, concrete washout water, sanitary wastes and trash/debris. (3)

## KYTC BMP Plan for Project CID 20-4410

### **B. Sediment and Erosion Control Measures:**

1. Plans for highway construction projects will include erosion control sheets that depict Disturbed Drainage Areas (DDAs) and related information. These plan sheets will show the existing project conditions with areas delineated by DDA within the right of way limits, the discharge points and the areas that drain to each discharge point. Project managers and designers will analyze the DDAs and identify Best Management Practices (BMPs) that are site specific. The balance of the BMPs for the project will be listed in the bid documents for selection and use by the Contractor on the project with approval by the Resident engineer.

Projects that do not have DDAs annotated on the erosion control sheets will employ the same concepts for development and managing BMP plans.

2. Following award of the contract, the Contractor and Resident engineer will annotate the erosion control sheets showing location and type of BMPs for each of the DDAs that will be disturbed at the outset of the project. This annotation will be accompanied by an order of work that reflects the order or sequence of major soil moving activities. The remaining DDAs are to be designated as "Do Not Disturb" until the Contractor and Resident engineer prepare the plan for BMPs to be employed. The initial BMP's shall be for the first phase (generally Clearing and Grubbing) and shall be modified as needed as the project changes phases. The BMP Plan will be modified to reflect disturbance in additional DDA's as the work progresses. All DDA's will have adequate BMP's in place before being disturbed.
3. As DDAs are prepared for construction, the following will be addressed for the project as a whole or for each DDA as appropriate:
  - Construction Access – This is the first land-disturbing activity. As soon as construction begins, bare areas will be stabilized with gravel and temporary mulch and/or vegetation.
  - At the beginning of the project, all DDAs for the project will be inspected for areas that are a source of storm water pollutants. Areas that are a source of pollutants will receive appropriate cover or BMPs to arrest the introduction of pollutants into storm water. Areas that have not been opened by the Contractor will be inspected periodically (once per month) to determine if there is a need to employ BMPs to keep pollutants from entering storm water.
  - Clearing and Grubbing – The following BMP's will be considered and used where appropriate.

## KYTC BMP Plan for Project CID 20-4410

- Leaving areas undisturbed when possible.
- Silt basins to provide silt volume for large areas.
- Silt Traps Type A for small areas.
- Silt Traps Type C in front of existing pipes and drop inlets which are to be saved
- Diversion ditches to catch sheet runoff and carry it to basins or traps or to divert it around areas to be disturbed.
- Brush and/or other barriers to slow and/or divert runoff.
- Silt fences to catch sheet runoff on short slopes. For longer slopes, multiple rows of silt fence may be considered.
- Temporary Mulch for areas which are not feasible for the fore mentioned types of protections.
- Non-standard or innovative methods.
- Cut & Fill and placement of drainage structures - The BMP Plan will be modified to show additional BMP's such as:
  - Silt Traps Type B in ditches and/or drainways as they are completed
  - Silt Traps Type C in front of pipes and drop inlets after they are placed
  - Channel Lining
  - Erosion Control Blanket
  - Temporary mulch and/or seeding for areas where construction activities will be ceased for 21 days or more.
  - Non-standard or innovative methods
- Profile and X-Section in place – The BMP Plan will be modified to show elimination of BMP's which had to be removed and the addition of new BMP's as the roadway was shaped. Probably changes include:
  - Silt Trap Type A, Brush and/or other barriers, Temporary Mulch, and any other BMP which had to be removed for final grading to take place.
  - Additional Silt Traps Type B and Type C to be placed as final drainage patterns are put in place.
  - Additional Channel Lining and/or Erosion Control Blanket.
  - Temporary Mulch for areas where Permanent Seeding and Protection cannot be done within 21 days.
  - Special BMP's such as Karst Policy
- Finish Work (Paving, Seeding, Protect, etc.) – A final BMP Plan will result from modifications during this phase of construction. Probable changes include:
  - Removal of Silt Traps Type B from ditches and drainways if they are protected with other BMP's which are sufficient to control erosion, i.e. Erosion Control Blanket or Permanent Seeding and Protection on moderate grades.
  - Permanent Seeding and Protection

## KYTC BMP Plan for Project CID 20-4410

- Placing Sod
- Planting trees and/or shrubs where they are included in the project
- BMP's including Storm Water Management Devices such as velocity dissipation devices and Karst policy BMP's to be installed during construction to control the pollutants in storm water discharges that will occur after construction has been completed are: *This project does not include storm water BMPs or flow controls for post-construction use.*

### C. Other Control Measures

1. No solid materials, including building materials, shall be discharged to waters of the commonwealth, except as authorized by a Section 404 permit.
2. Waste Materials

All waste materials that may leach pollutants (paint and paint containers, caulk tubes, oil/grease containers, liquids of any kind, soluble materials, etc.) will be collected and stored in appropriate covered waste containers. Waste containers shall be removed from the project site on a sufficiently frequent basis as to not allow wastes to become a source of pollution. All personnel will be instructed regarding the correct procedure for waste disposal. Wastes will be disposed in accordance with appropriate regulations. Notices stating these practices will be posted in the office.

3. Hazardous Waste

All hazardous waste materials will be managed and disposed of in the manner specified by local or state regulation. The Contractor shall notify the Section Engineer if there any hazardous wastes being generated at the project site and how these wastes are being managed. Site personnel will be instructed with regard to proper storage and handling of hazardous wastes when required. The Transportation Cabinet will file for generator, registration when appropriate, with the Division of Waste Management and advise the Contractor regarding waste management requirements.

4. Spill Prevention

The following material management practices will be used to reduce the risk of spills or other exposure of materials and substances to the weather and/or runoff.

- **Good Housekeeping:**

## KYTC BMP Plan for Project CID 20-4410

The following good housekeeping practices will be followed onsite during the construction project.

- An effort will be made to store only enough product required to do the job
- All materials stored onsite will be stored in a neat, orderly manner in their appropriate containers and, if possible, under a roof or other enclosure
- Products will be kept in their original containers with the original manufacturer's label
- Substances will not be mixed with one another unless recommended by the manufacturer
- Whenever possible, all of the product will be used up before disposing of the container
- Manufacturers' recommendations for proper use and disposal will be followed
- The site Contractor will inspect daily to ensure proper use and disposal of materials onsite

### ➤ **Hazardous Products:**

These practices will be used to reduce the risks associated with any and all hazardous materials.

- Products will be kept in original containers unless they are not resealable
- Original labels and material safety data sheets (MSDS) will be reviewed and retained
- Contractor will follow procedures recommended by the manufacturer when handling hazardous materials
- If surplus product must be disposed of, manufacturers' or state/local recommended methods for proper disposal will be followed

### **The following product-specific practices will be followed onsite:**

#### ➤ **Petroleum Products:**

Vehicles and equipment that are fueled and maintained on site will be monitored for leaks, and receive regular preventative maintenance to reduce the chance of leakage. Petroleum products onsite will be stored in tightly sealed containers, which are clearly labeled and will be protected from exposure to weather.

The Contractor shall prepare an Oil Pollution Spill Prevention Control and Countermeasure plan when the project that involves the storage of petroleum products in 55 gallon or larger containers with a total combined storage capacity of 1,320 gallons. This is a requirement of 40 CFR 112.

## KYTC BMP Plan for Project CID 20-4410

This project (will / will not) (3) have over 1,320 gallons of petroleum products with a total capacity, sum of all containers 55 gallon capacity and larger.

### ➤ **Fertilizers:**

Fertilizers will be applied at rates prescribed by the contract, standard specifications or as directed by the Resident engineer. Once applied, fertilizer will be covered with mulch or blankets or worked into the soil to limit exposure to storm water. Storage will be in a covered shed. The contents of any partially used bags of fertilizer will be transferred to a sealable plastic bin to avoid spills.

### ➤ **Paints:**

All containers will be tightly sealed and stored indoors or under roof when not being used. Excess paint or paint wash water will not be discharged to the drainage or storm sewer system but will be properly disposed of according to manufacturers' instructions or state and local regulations.

### ➤ **Concrete Truck Washout:**

Concrete truck mixers and chutes will not be washed on pavement, near storm drain inlets, or within 75 feet of any ditch, stream, wetland, lake, or sinkhole. Where possible, excess concrete and wash water will be discharged to areas prepared for pouring new concrete, flat areas to be paved that are away from ditches or drainage system features, or other locations that will not drain off site. Where this approach is not possible, a shallow earthen wash basin will be excavated away from ditches to receive the wash water

### ➤ **Spill Control Practices**

In addition to the good housekeeping and material management practices discussed in the previous sections of this plan, the following practices will be followed for spill prevention and cleanup:

- Manufacturers' recommended methods for spill cleanup will be clearly posted. All personnel will be made aware of procedures and the location of the information and cleanup supplies.
- Materials and equipment necessary for spill cleanup will be kept in the material storage area. Equipment and materials will include as appropriate, brooms, dust pans, mops, rags, gloves, oil absorbents, sand, sawdust, and plastic and metal trash containers.
- All spills will be cleaned up immediately after discovery.
- The spill area will be kept well ventilated and personnel will wear appropriate protective clothing to prevent injury from contact with a hazardous substance.

## KYTC BMP Plan for Project CID 20-4410

- Spills of toxic or hazardous material will be reported to the appropriate state/local agency as required by KRS 224 and applicable federal law.
- The spill prevention plan will be adjusted as needed to prevent spills from reoccurring and improve spill response and cleanup.
- Spills of products will be cleaned up promptly. Wastes from spill clean up will be disposed in accordance with appropriate regulations.

### **D. Other State and Local Plans**

This BMP plan shall include any requirements specified in sediment and erosion control plans, storm water management plans or permits that have been approved by other state or local officials. Upon submittal of the NOI, other requirements for surface water protection are incorporated by reference into and are enforceable under this permit (even if they are not specifically included in this BMP plan). This provision does not apply to master or comprehensive plans, non-enforceable guidelines or technical guidance documents that are not identified in a specific plan or permit issued for the construction site by state or local officials. *There are no other local (MS4) requirements that are expected to be necessary for this project.*

### **E. Maintenance**

1. The BMP plan shall include a clear description of the maintenance procedures necessary to keep the control measures in good and effective operating condition.
- Maintenance of BMPs during construction shall be a result of weekly and post rain event inspections with action being taken by the Contractor to correct deficiencies.
  - Post Construction maintenance will be a function of normal highway maintenance operations. Following final project acceptance by the cabinet, district highway crews will be responsible for identification and correction of deficiencies regarding ground cover and cleaning of storm water BMPs. The project manager shall identify any BMPs that will be for the purpose of post construction storm water management with specific guidance for any non-routine maintenance. *There are no such BMP's for this project.*

### **F. Inspections**

Inspection and maintenance practices that will be used to maintain erosion and sediment controls:

## KYTC BMP Plan for Project CID 20-4410

- All erosion prevention and sediment control measures will be inspected at least once each week and following any rain of one-half inch or more.
- Inspections will be conducted by individuals that have successfully completed the KEPSC-RI course as required by Section 213.02.02 of the Standard Specifications for Road and Bridge Construction, current edition.
- Inspection reports will be written, signed, dated, and kept on file.
- Areas at final grade will be seeded and mulched within 14 days.
- Areas that are not at final grade where construction has ceased for a period of 21 days or longer and soil stock piles shall receive temporary mulch no later than 14 days from the last construction activity in that area.
- All measures will be maintained in good working order; if a repair is necessary, it will be initiated within 24 hours of being reported.
- Built-up sediment will be removed from behind the silt fence before it has reached halfway up the height of the fence.
- Silt fences will be inspected for bypassing, overtopping, undercutting, depth of sediment, tears, and to ensure attachment to secure posts.
- Sediment basins will be inspected for depth of sediment, and built-up sediment will be removed when it reaches 50 percent of the design capacity and at the end of the job.
- Diversion dikes and berms will be inspected and any breaches promptly repaired. Areas that are eroding or scouring will be repaired and re-seeded / mulched as needed.
- Temporary and permanent seeding and mulching will be inspected for bare spots, washouts, and healthy growth. Bare or eroded areas will be repaired as needed.
- All material storage and equipment servicing areas that involve the management of bulk liquids, fuels, and bulk solids will be inspected weekly for conditions that represent a release or possible release of pollutants to the environment.

## **G. Non – Storm Water discharges**

It is expected that non-storm water discharges may occur from the site during the construction period. Examples of non-storm water discharges include:

- Water from water line flushings.
- Water from cleaning concrete trucks and equipment.
- Pavement wash waters (where no spills or leaks of toxic or hazardous materials have occurred).

## KYTC BMP Plan for Project CID 20-4410

- Uncontaminated groundwater and rain water (from dewatering during excavation).

All non-storm water discharges will be directed to the sediment basin or to a filter fence enclosure in a flat vegetated infiltration area or be filtered via another approved commercial product.

### H. Groundwater Protection Plan (3)

This plan serves as the groundwater protection plan as required by 401 KAR 5:037.

- Contractors statement: (3)

The following activities, as enumerated by 401 KAR 5:037 Section 2 that require the preparation and implementation of a groundwater protection plan, will or may be conducted as part of this construction project:

\_\_\_\_\_ 2. (e) land treatment or land disposal of a pollutant;

\_\_\_\_\_ 2. (f) Storing, ..., or related handling of hazardous waste, solid waste or special waste, ..., in tanks, drums, or other containers, or in piles, (This does not include wastes managed in a container placed for collection and removal of municipal solid waste for disposal off site);

\_\_\_\_\_ 2. (g) .... Handling of materials in bulk quantities (equal or greater than 55 gallons or 100 pounds net dry weight transported held in an individual container) that, if released to the environment, would be a pollutant;

\_\_\_\_\_ 2. (j) Storing or related handling of road oils, dust suppressants, ....., at a central location;

\_\_\_\_\_ 2. (k) Application or related handling of road oils, dust suppressants or deicing materials, (does not include use of chloride-based deicing materials applied to roads or parking lots);

\_\_\_\_\_ 2. (m) Installation, construction, operation, or abandonment of wells, bore holes, or core holes, (this does not include bore holes for the purpose of explosive demolition);

Or, check the following only if there are no qualifying activities

\_\_\_\_\_ There are no activities for this project as listed in 401 KAR 5:037 Section 2 that require the preparation and implementation of a groundwater protection plan.

## KYTC BMP Plan for Project CID 20-4410

The Contractor is responsible for the preparation of a plan that addresses the

401 KAR 5:037 Section 3. (3) Elements of site specific groundwater protection plan:

- (a) General information about this project is covered in the Project information;
- (b) Activities that require a groundwater protection plan have been identified above;
- (c) Practices that will protect groundwater from pollution are addressed in section C. Other control measures.
- (d) Implementation schedule – all practices required to prevent pollution of groundwater are to be in place prior to conducting the activity;
- (e) Training is required as a part of the ground water protection plan. All employees of the Contractor, sub-contractor and Resident engineer personnel will be trained to understand the nature and requirements of this plan as they pertain to their job function(s). Training will be accomplished within one week of employment and annually thereafter. A record of training will be maintained by the Contractor with a copy provide to the Resident engineer.
- (f) Areas of the project and groundwater plan activities will be inspected as part of the weekly sediment and erosion control inspections
- (g) Certification (see signature page.)



KYTC BMP Plan for Project CID 20-4410

### Sub-Contractor Certification

The following sub-contractor shall be made aware of the BMP plan and responsible for implementation of BMPs identified in this plan as follows:

Subcontractor

Name:  
Address:  
Address:

Phone:

The part of BMP plan this subcontractor is responsible to implement is:

I certify under penalty of law that I understand the terms and conditions of the general Kentucky Pollutant Discharge Elimination System permit that authorizes the storm water discharges, the BMP plan that has been developed to manage the quality of water to be discharged as a result of storm events associated with the construction site activity and management of non-storm water pollutant sources identified as part of this certification.

Signed \_\_\_\_\_ title \_\_\_\_\_, \_\_\_\_\_  
Typed or printed name<sup>1</sup> signature

1. Sub Contractor Note: to be signed by a person who is the owner, a responsible corporate officer, a general partner or the proprietor or a person designated to have the authority to sign reports by such a person in accordance with 401 KAR 5:060 Section 9. This delegation shall be in writing to: Manager, KPDES Branch, Division of Water, 14 Reilly Road, Frankfort Kentucky 40601. Reference the Project Control Number (PCN) and KPDES number when one has been issued.

**CID 20-4410**  
**Union County**  
**Highway Safety Improvement Project along KY-130**  
**from MP 9.584 – 15.567**  
**Item No.: 2-9009**

---

An electronic Notice of Intent (eNOI) for obtaining coverage under the Kentucky Pollutant Discharge Elimination System (KPDES) General Permit for Stormwater Discharges Associated with Construction Activities (KYR10) has been drafted, a copy of which is attached. Upon award, the Contractor will be identified in Section III of the form as the “Building Contractor” and the eNOI will be submitted for approval to the Kentucky Division of Water. The Contractor shall be responsible for advancing the work within this contract in a manner that is compliant with all applicable and appropriate KYTC specifications for sediment and erosion control, as well as meeting the requirements of the KYR10 permit and the KDOW.

**eForm Submittal ID: 205416**

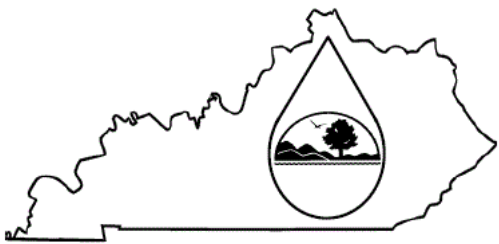
	<h2 style="margin: 0;">KENTUCKY POLLUTION DISCHARGE</h2> <h3 style="margin: 0;">ELIMINATION SYSTEM (KPDES)</h3> <p style="margin: 0;">Notice of Intent (NOI) for coverage of Storm Water Discharge                  Associated with Construction Activities Under the KPDES Storm                  Water General Permit KYR100000</p> <p style="margin: 0; text-align: center;"> <a href="#">Click here for Instructions                      (Controls/KPDES_FormKYR10_Instructions.htm)</a> </p> <p style="margin: 0; text-align: center;"> <a href="http://dep.ky.gov/formslibrary/Documents/KYR10PermitPage.pdf">Click here to obtain information and a copy of the KPDES General Permit.                      (http://dep.ky.gov/formslibrary/Documents/KYR10PermitPage.pdf)</a> </p> <p style="margin: 0; text-align: center; font-size: small;">                     (*) indicates a required field; (✓) indicates a field may be required based on user input or is an optionally required field                 </p>
---	---

Reason for Submittal:(*) <input type="text" value="Application for New Permit Coverage"/>	Agency Interest ID: <input type="text" value="Agency Interest ID"/>	Permit Number:(✓) <input type="text" value="KPDES Permit Number"/>
--	--	---

If change to existing permit coverage is requested, describe the changes for which modification of coverage is being sought:(✓)

**ELIGIBILITY:**  
 Stormwater discharges associated with construction activities disturbing individually one (1) acre or more, including, in the case of a common plan of development, contiguous construction activities that cumulatively equal one (1) acre or more of disturbance.

**EXCLUSIONS:**  
 The following are excluded from coverage under this general permit:

- 1) Are conducted at or on properties that have obtained an individual KPDES permit for the discharge of other wastewaters which requires the development and implementation of a Best Management Practices (BMP) plan;
- 2) Any operation that the DOW determines an individual permit would better address the discharges from that operation;
- 3) Any project that discharges to an Impaired Water listed in the most recent Integrated Report, §305(b) as impaired for sediment and for which an approved TMDL has been developed.

**SECTION I -- FACILITY OPERATOR INFORMATION (PERMITTEE)**

Company Name:(✓) <input type="text" value="Kentucky Transportation Cabinet, District 2"/>	First Name:(✓) <input type="text" value="Deneatra"/>	M.I.: <input type="text" value="MI"/>	Last Name:(✓) <input type="text" value="Henderson"/>
Mailing Address:(*) <input type="text" value="1840 North Main Street"/>	City:(*) <input type="text" value="Madisonville"/>	State:(*) <input type="text" value="Kentucky"/>	Zip:(*) <input type="text" value="42431"/>
eMail Address:(*) <input type="text" value="Deneatra.Henderson@ky.gov"/>	Business Phone:(*) <input type="text" value="270-871-2582"/>	Alternate Phone: <input type="text" value="Phone"/>	

**SECTION II -- GENERAL SITE LOCATION INFORMATION**

Project Name:(*) <input type="text" value="KYTC Project: CID 204410"/>	Status of Owner/Operator(*) <input type="text" value="State Government"/>	SIC Code(*) <input type="text" value="1611 Highway and Street Const"/>
Company Name:(✓) <input type="text" value="Company Name"/>	First Name:(✓) <input type="text" value="First Name"/>	M.I.: <input type="text" value="MI"/>
Last Name:(✓) <input type="text" value="Last Name"/>		
Site Physical Address:(*) <input type="text" value="KY 130"/>		
City:(*) <input type="text" value="Morganfield"/>	State:(*) <input type="text" value="Kentucky"/>	Zip:(*) <input type="text" value="42437"/>
County:(*) <input type="text" value="Union"/>	Latitude(decimal degrees)(*)DMS to DD Converter (https://www.fcc.gov/media/radio/dms-decimal) <input type="text" value="37.728486"/>	Longitude(decimal degrees)(*) <input type="text" value="-87.920960"/>

**SECTION III -- SPECIFIC SITE ACTIVITY INFORMATION**

Project Description:(\*)

a. For single projects provide the following information

Total Number of Acres in Project:(√) <input type="text" value="37.9"/>	Total Number of Acres Disturbed:(√) <input type="text" value="17.9"/>
Anticipated Start Date:(√) <input type="text"/>	Anticipated Completion Date:(√) <input type="text"/>

b. For common plans of development provide the following information

Total Number of Acres in Project:(√) <input type="text" value="# Acre(s)"/>	Total Number of Acres Disturbed:(√) <input type="text" value="# Acre(s)"/>
Number of individual lots in development, if applicable:(√) <input type="text" value="# lot(s)"/>	Number of lots in development:(√) <input type="text" value="# lot(s)"/>
Total acreage of lots intended to be developed:(√) <input type="text" value="Project Acres"/>	Number of acres intended to be disturbed at any one time:(√) <input type="text" value="Disturbed Acres"/>
Anticipated Start Date:(√) <input type="text"/>	Anticipated Completion Date:(√) <input type="text"/>

List Building Contractor(s) at the time of Application:(\*)

Company Name
+ <input type="text"/>

SECTION IV -- IF THE PERMITTED SITE DISCHARGES TO A WATER BODY THE FOLLOWING INFORMATION IS REQUIRED ?

Discharge Point(s):

	Unnamed Tributary?	Latitude	Longitude	Water Name	Delete
29	No	37.748571	-87.923225	Lost Creek	Delete
30	No	37.748612	-87.923076	Lost Creek	Delete
31	No	37.751348	-87.923248	Lost Creek	Delete
32	No	37.751431	-87.923461	Lost Creek	Delete
33	Yes	37.753658	-87.923256	Lost Creek	Delete
34	Yes	37.754401	-87.922835	Lost Creek	Delete
35	Yes	37.754650	-87.922711	Lost Creek	Delete
36	Yes	37.755897	-87.923381	Lost Creek	Delete
37	Yes	37.758154	-87.924390	Lost Creek	Delete
38	Yes	37.761855	-87.926708	Lost Creek	Delete

SECTION V -- IF THE PERMITTED SITE DISCHARGES TO A MS4 THE FOLLOWING INFORMATION IS REQUIRED ?

Name of MS4:

Date of application/notification to the MS4 for construction site permit coverage: <input type="text" value="Date"/>	Discharge Point(s):(*) <table border="1"> <thead> <tr> <th>Latitude</th> <th>Longitude</th> </tr> </thead> <tbody> <tr> <td>+ <input type="text"/></td> <td><input type="text"/></td> </tr> </tbody> </table>	Latitude	Longitude	+ <input type="text"/>	<input type="text"/>
Latitude	Longitude				
+ <input type="text"/>	<input type="text"/>				

SECTION VI -- WILL THE PROJECT REQUIRE CONSTRUCTION ACTIVITIES IN A WATER BODY OR THE RIPARIAN ZONE?

Will the project require construction activities in a water body or the riparian zone?: (*)	<input type="text" value="No"/>
If Yes, describe scope of activity: (√)	<input type="text" value="describe scope of activity"/>
Is a Clean Water Act 404 permit required?:(*)	<input type="text" value="No"/>

Is a Clean Water Act 401 Water Quality Certification required?:(*)		No	
<b>SECTION VII -- NOI PREPARER INFORMATION</b>			
First Name:(*) First Name	M.I.: MI	Last Name:(*) Last Name	Company Name:(*) Company Name
Mailing Address:(*) Mailing Address	City:(*) City	State:(*)	Zip:(*) Zip
eMail Address:(*) eMail Address	Business Phone:(*) Phone	Alternate Phone: Phone	
<b>SECTION VIII -- ATTACHMENTS</b>			
Facility Location Map:(*)	Upload file		
Supplemental Information:	Upload file		
<b>SECTION IX -- CERTIFICATION</b>			
I certify under penalty of law that this document and all attachments were prepared under my direction or supervision in accordance with a system designed to assure that qualified personnel properly gather and evaluate the information submitted. Based on my inquiry of the person or persons who manage the system, or those persons directly responsible for gathering the information submitted is, to the best of my knowledge and belief, true, accurate, and complete. I am aware that there are significant penalties for submitting false information, including the possibility of fine and imprisonment for knowing violations.			
Signature:(*) Signature	Title:(*) Title		
First Name:(*) First Name	M.I.: MI	Last Name:(*) Last Name	
eMail Address:(*) eMail Address	Business Phone:(*) Phone	Alternate Phone: Phone	Signature Date:(*) Date
<div style="display: flex; justify-content: space-around; margin-top: 20px;"> <span>Click to Save Values for Future Retrieval</span> <span>Click to Submit to EEC</span> </div>			

COUNTY OF	ITEM NO.
UNION	2-9009

☉ KY 130 STA 580+00

POINT	LATITUDE	LONGITUDE
DDA 1	37.691929	-87.913276
DDA 2	37.696081	-87.913517
DDA 3	37.697984	-87.914041
DDA 4	37.698056	-87.913574
DDA 5	37.701637	-87.914345
DDA 6	37.702554	-87.914522
DDA 7	37.702717	-87.914274
DDA 8	37.704666	-87.914767
DDA 9	37.704910	-87.914386

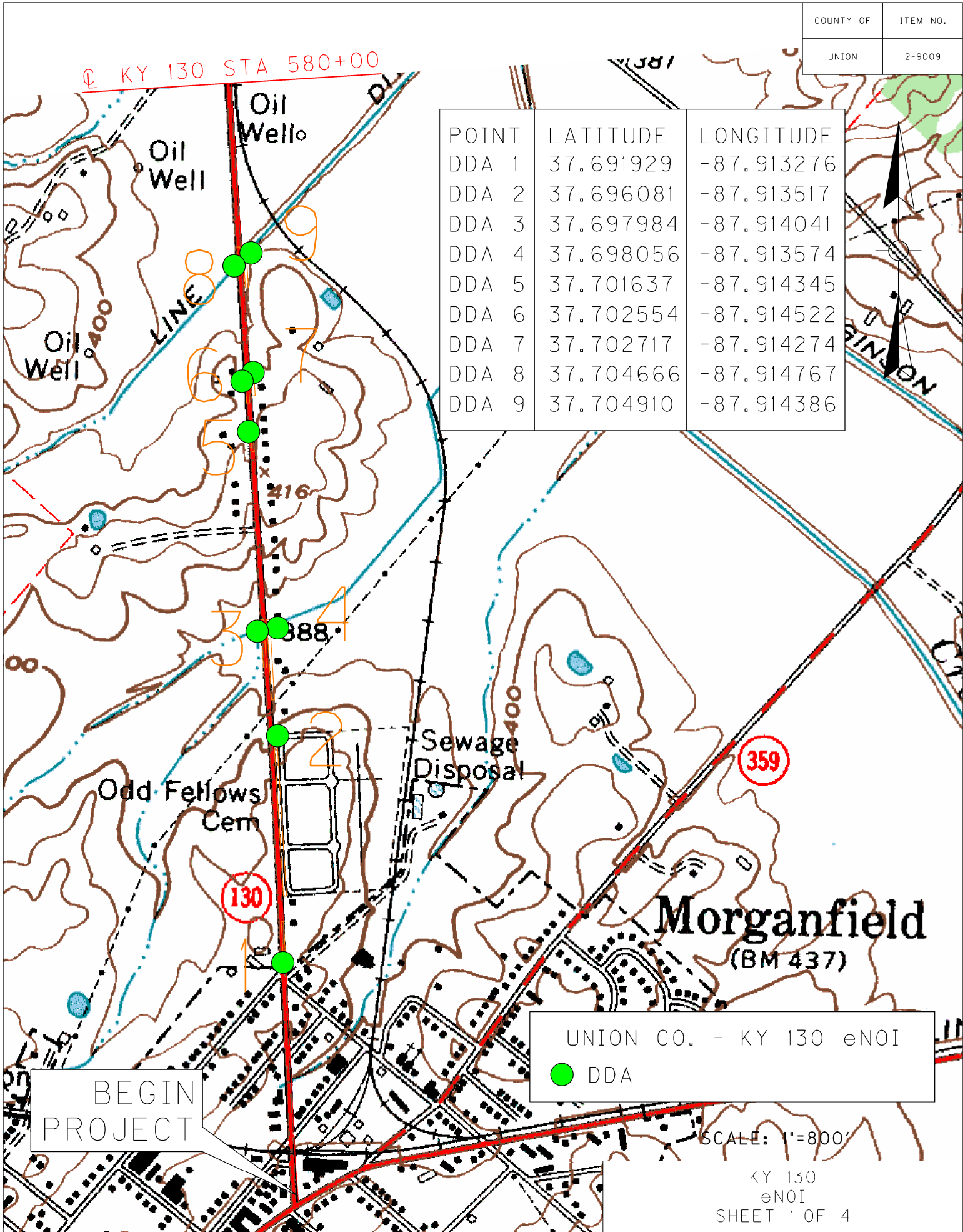

UNION CO. - KY 130 eNOI  
 ● DDA

BEGIN PROJECT

SCALE: 1"=800'

KY 130  
 eNOI  
 SHEET 1 OF 4

COUNTY OF	ITEM NO.
UNION	2-9009

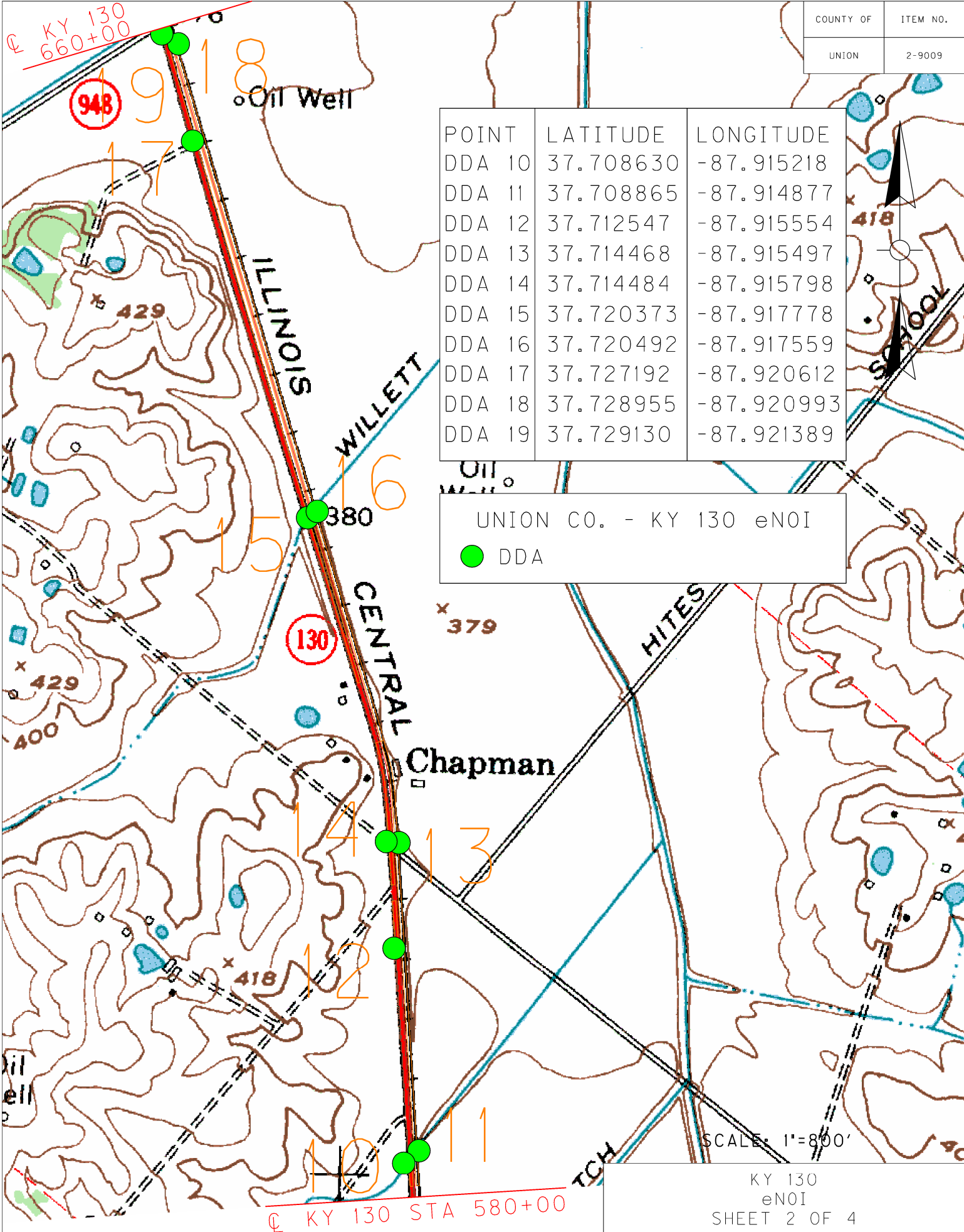

POINT	LATITUDE	LONGITUDE
DDA 10	37.708630	-87.915218
DDA 11	37.708865	-87.914877
DDA 12	37.712547	-87.915554
DDA 13	37.714468	-87.915497
DDA 14	37.714484	-87.915798
DDA 15	37.720373	-87.917778
DDA 16	37.720492	-87.917559
DDA 17	37.727192	-87.920612
DDA 18	37.728955	-87.920993
DDA 19	37.729130	-87.921389

UNION CO. - KY 130 eNOI  
 ● DDA

SCALE: 1"=800'

KY 130  
 eNOI  
 SHEET 2 OF 4

☉ KY 130  
 660+00

☉ KY 130 STA 580+00

☉ KY 130 STA 735+00

COUNTY OF	ITEM NO.
UNION	2-9009

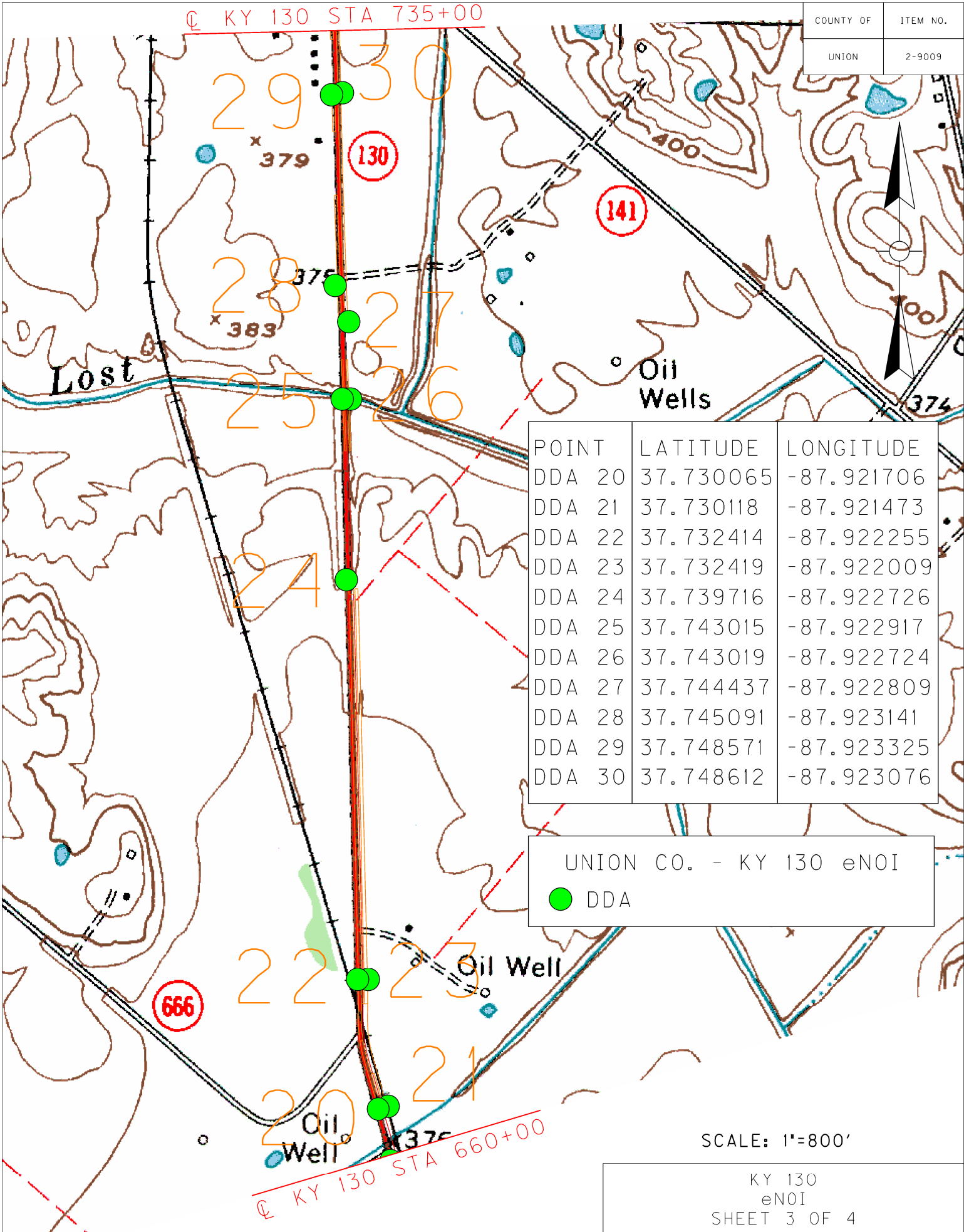

POINT	LATITUDE	LONGITUDE
DDA 20	37.730065	-87.921706
DDA 21	37.730118	-87.921473
DDA 22	37.732414	-87.922255
DDA 23	37.732419	-87.922009
DDA 24	37.739716	-87.922726
DDA 25	37.743015	-87.922917
DDA 26	37.743019	-87.922724
DDA 27	37.744437	-87.922809
DDA 28	37.745091	-87.923141
DDA 29	37.748571	-87.923325
DDA 30	37.748612	-87.923076

UNION CO. - KY 130 eNOI  
● DDA

SCALE: 1"=800'

KY 130  
eNOI  
SHEET 3 OF 4

END  
PROJECT

COUNTY OF	ITEM NO.
UNION	2-9009

POINT	LATITUDE	LONGITUDE
DDA 31	37.751348	-87.923248
DDA 32	37.751431	-87.923461
DDA 33	37.753658	-87.923256
DDA 34	37.754401	-87.922835
DDA 35	37.754650	-87.922711
DDA 36	37.755897	-87.923381
DDA 37	37.758154	-87.924390
DDA 38	37.761855	-87.926708

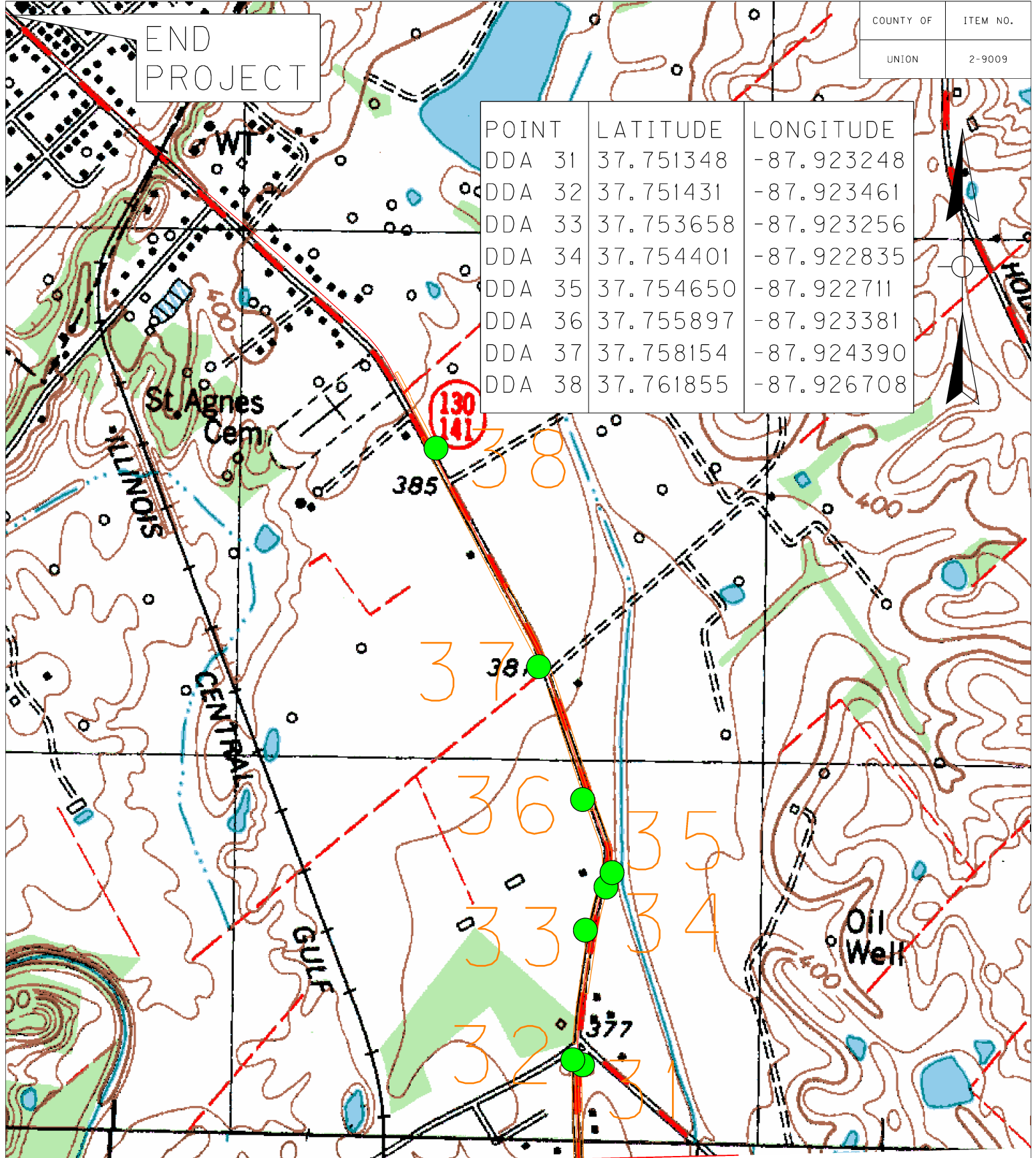

Q KY 130 STA 735+00

UNION CO. - KY 130 eNOI  
● DDA

SCALE: 1"=800'

KY 130  
eNOI  
SHEET 4 OF 4



# Commonwealth of Kentucky DEPARTMENT OF HIGHWAYS

## PLANS OF PROPOSED PROJECT

### CORRIDOR IMPROVEMENTS UNION COUNTY KY 130

COUNTY OF	ITEM NO.
UNION	2-9009

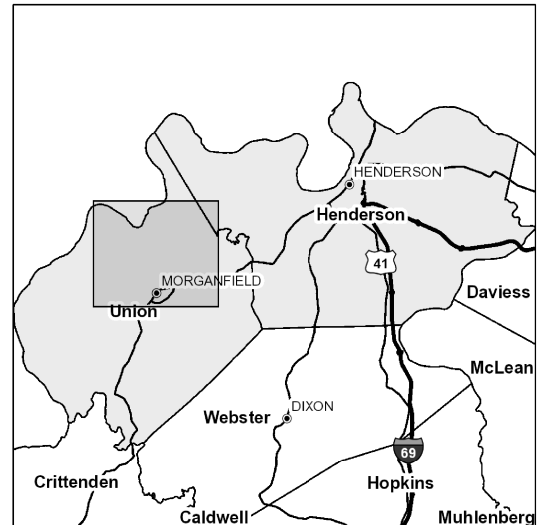
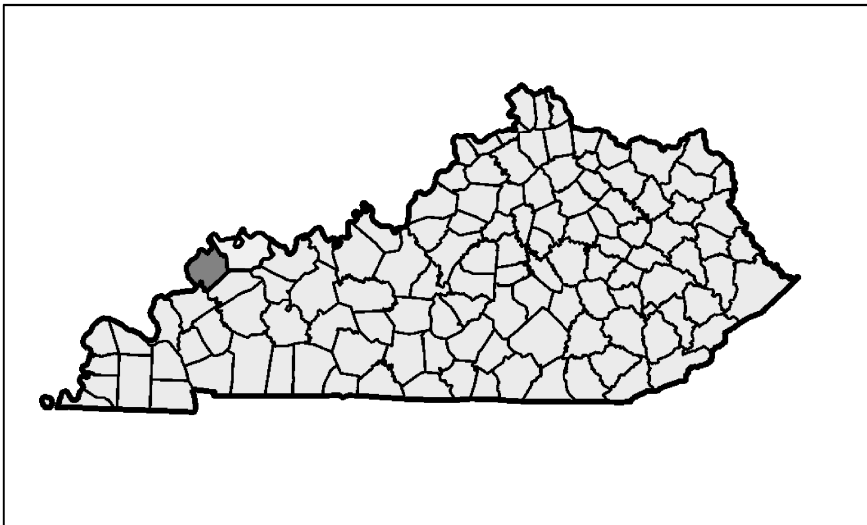
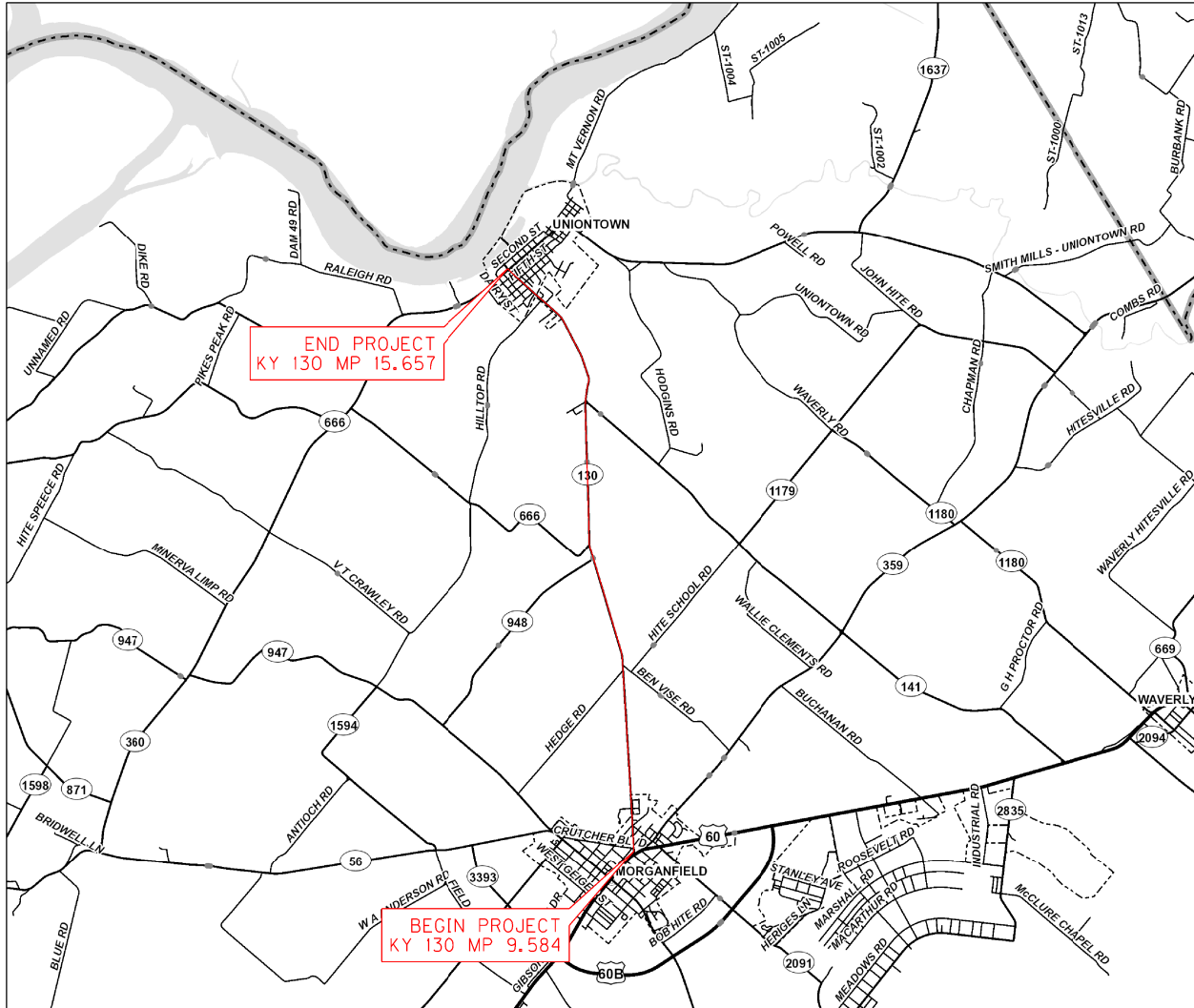



KY 130  
GENERAL SUMMARY

COUNTY OF	ITEM NO.	FEDERAL NO.
UNION	2-9009.00	5049 (006)

ITEM	DESCRIPTION	UNIT	TOTAL PROJECT
① 1	DGA BASE	TON	622
20	TRAFFIC BOUND BASE	TON	25
100	ASPHALT SEAL AGGREGATE	TON	5
103	ASPHALT SEAL COAT	TON	0.6
190	LEVELING & WEDGING PG64-22	TON	935
212	CL2 ASPH BASE 1.00D PG64-22	TON	1,149
301	CL2 ASPH SURF 0.38D PG64-22	TON	4,838
23362ES403	CL2 ASPH SURF 0.5B PG64-22	TON	154
441	ENTRANCE PIPE-18 IN	LF	77
② 462	CULVERT PIPE-18 IN	LF	12
② 464	CULVERT PIPE-24 IN	LF	13
③ 1310	REMOVE PIPE	LF	90
1987	DELINEATOR FOR GUARDRAIL BI DIRECTIONAL WHITE	EACH	16
④ 1987	DELINEATOR FOR GUARDRAIL BI DIRECTIONAL WHITE (LUCIOL SYSTEMS BIDIRECTIONAL LINEAR DELINEATION)	EACH	44
2351	GUARDRAIL-STEEL W BEAM-S FACE	LF	1,345.00
2360	GUARDRAIL TERMINAL SECTION NO 1	EACH	2
2367	GUARDRAIL END TREATMENT TYPE 1	EACH	9
2378	GUARDRAIL CONNECTOR TO BRIDGE END TY D	EACH	4
2381	REMOVE GUARDRAIL	LF	200.00
2396	REMOVE GUARDRAIL END TREATMENT	EACH	3
⑤ 2483	CHANNEL LINING CLASS II	TON	630
2562	TEMPORARY SIGNS	SQFT	603.00
2569	DEMobilIZATION (UNION KY 130 HSIP)	LS	1
2575	DITCHING AND SHOULDERING	LF	31,259
2603	FABRIC-GEOTEXTILE CLASS 2	SQYD	190
2607	FABRIC-GEOTEXTILE CLASS 2 FOR PIPE	SQYD	52
2625	REMOVE HEADWALL	EACH	1
2650	MAINTAIN & CONTROL TRAFFIC (UNION KY 130 HSIP)	LS	1
2671	PORTABLE CHANGEABLE MESSAGE SIGN	EACH	2
2676	MOBILIZATION FOR MILL & TEXT (UNION KY 130 HSIP)	LS	1
⑥ 2677	ASPHALT PAVE MILLING & TEXTURING	TON	339
2697	EDGE LINE RUMBLE STRIPS	LF	60,705
2701	TEMP SILT FENCE	LF	13,755
2703	SILT TRAP TYPE A	EACH	18

- ① 577 TONS FROM SHOULDER WIDENING SUMMARY AND 45 TONS FROM DITCHING AND SHOULDERING SUMMARY.
- ② PIPE EXTENSION SHALL BE OF IN-KIND MATERIAL.
- ③ 20 LF FROM PIPE REPLACEMENT AND EXTENSION SUMMARY AND 70 LF FROM ENTRANCE PIPE SUMMARY.
- ④ TO COVER THE EXPERIMENTAL IMPLEMENTATION OF 637.5 LF OF LUCIOL SYSTEMS ADVANCED DELINEATION AT THE LOCATION SPECIFIED IN THE GUARDRAIL SUMMARY.
- ⑤ 42 TONS FROM PIPE REPLACEMENT AND EXTENSION SUMMARY AND 588 TONS FROM DITCHING AND SHOULDERING SUMMARY.
- ⑥ 283 TONS FROM SUPERELEVATION IMPROVEMENT SUMMARY AND 56 TONS FROM RESURFACING SUMMARY.



KY 130  
GENERAL SUMMARY

COUNTY OF	ITEM NO.	FEDERAL NO.
UNION	2-9009.00	5049 (006)

ITEM	DESCRIPTION	UNIT	TOTAL PROJECT
2704	SILT TRAP TYPE B	EACH	18
2705	SILT TRAP TYPE C	EACH	18
2706	CLEAN SILT TRAP TYPE A	EACH	18
2707	CLEAN SILT TRAP TYPE B	EACH	18
2708	CLEAN SILT TRAP TYPE C	EACH	18
2726	STAKING (UNION KY 130 HSIP)	LS	1
3240	BASE FAILURE REPAIR	SQYD	631
5950	EROSION CONTROL BLANKET	SQYD	31,259
5952	TEMP MULCH	SQYD	57,760
5953	TEMP SEEDING AND PROTECTION	SQYD	43,320
5963	INITIAL FERTILIZER	TON	0.5
5964	MAINTENANCE FERTILIZER	TON	0.3
5985	SEEDING AND PROTECTION	SQYD	52,251
5990	SODDING	SQYD	3,126
6406	SBM ALUM SHEET SIGNS .080 IN	SQFT	446.63
6407	SBM ALUM SHEET SIGNS .125 IN	SQFT	77.84
6410	STEEL POST TYPE 1	LF	978
⑦ 6510	PAVE STRIPING-TEMP PAINT-4 IN	LF	13,376
6542	PAVE STRIPING-THERMO-6 IN W	LF	60,705
6543	PAVE STRIPING-THERMO-6 IN Y	LF	32,065
6556	PAVE STRIPING-DUR TY 1-6 IN W	LF	230
6557	PAVE STRIPING-DUR TY 1-6 IN Y	LF	230
8100	CONCRETE-CLASS A	CUYD	6.39
10020NS	FUEL ADJUSTMENT	DOLL	10,962
10030NS	ASPHALT ADJUSTMENT	DOLL	27,534
20748ED	SHOULDER MILLING/TRENCHING	SQYD	5,222
21373ND	REMOVE SIGN	EACH	73
24575ES610	HEADWALL (18 INCH TRIPLE PIPE CULVERT)	EACH	1
24575ES610	HEADWALL (24 INCH STANDARD CONCRETE)	EACH	1
24575ES610	HEADWALL (SLOPED & MITERED CONCRETE-FOR 24 INCH PIPE)	EACH	1
24575ES610	HEADWALL (SLOPED & MITERED CONCRETE-FOR 36 INCH PIPE)	EACH	1
24631EC	BARCODE SIGN INVENTORY	EACH	133
⑧ 24970EC	ASPHALT MATERIAL FOR TACK NON-TRACKING	TON	25.2

⑦ FOR USE IN MAINTAINING TRAFFIC DURING SUPERELEVATION CORRECTIONS. ENGINEER SHALL HAVE FINAL APPROVAL OF LAYOUT PRIOR TO APPLICATION.

⑧ 2.7 TONS FROM SUPERELEVATION IMPROVEMENT SUMMARY AND 22.5 TONS FROM RESURFACING SUMMARY.

## Base Failure Repair Summary

Begin Milepoint	Begin Station	RT / LT	Length (LF)	Width (FT)	Area (SY)
9.700	512+16	LT	80	4	36
9.700	512+16	RT	25	4	12
9.800	517+44	LT	200	4	89
9.872	521+25	LT	275	6	184
9.900	522+72	RT	20	4	9
10.519	555+40	LT	140	6	94
13.210	697+50	LT	125	6	84
13.835	730+50	RT	75	6	50
15.300	807+84	LT	10	4	5
15.400	813+12	RT	40	4	18
15.500	818+40	RT	20	4	9
15.600	823+68	RT	80	4	36
15.600	823+68	LT	10	4	5
				<b>TOTAL</b>	<b>631 SY</b>

**Note:** Exact limits of each application are to be defined by the Project Engineer.

**SUPERELEVATION IMPROVEMENT SUMMARY**

Begin Milepoint	Station	End Milepoint	Station	Width of Section (FT)	Length of Section (FT)	Runoff Length (FT)	Runout Length (FT)	Existing Superelevation	Proposed Superelevation	Asph. Pave. Mill & Text (Tons)	Asph. Material for Tack Non-Tracking (Tons)	Leveling & Wedging (Tons)	Comments
11.472	605+71	11.565	610+65	26	494	90	45	1.0% - 1.4%	4.0% LT	85	0.7	231	
12.600	665+29	12.698	670+44	26	515	90	45	1.5% - 1.8%	4.0% RT	101	1.6	329	Includes 92 Tons of Leveling & Wedging for vertically tying KY 666 to the new KY 130 pavement.
14.205	750+04	14.331	756+67	26	663	159	40	6.2% - 7.6%	8.0% LT	97	0.4	375	Prior to the runout preceeding the curve in the northbound direction, the existing cross slopes are to be transitioned to normal crown. 100 FT of length is planned for this transition.
<b>TOTALS</b>										<b>283 TONS</b>	<b>2.7 TONS</b>	<b>935 TONS</b>	

NOTES: NOTES: These numbers are for estimate purposes only. Final locations and quantities will be determined by the Engineer in the field.

**SHOULDER WIDENING SUMMARY**

NOTES: These numbers are for estimate purposes only. Final locations and quantities will be determined by the Engineer in the field.  
\* Ditching & Shouldering to be performed as part of shoulder widening will be detailed on the Ditching & Shouldering Summary. Ditching & Shouldering quantities shown here are for informational purposes only.  
\*\* Refer to the Shoulder Widening Detail for specifics of the widening dimensions.

Begin Milepoint	Station	End		LT / RT	Width ** (FT)	Depth ** (IN)	Length (LF)	Milling/ Trenching (SY)	DGA Base (Tons)	CL2 Asph. Base 1,00D PG64-22 (Tons)	Ditching & Shouldering* (LF)	Comments
		Milepoint	Station									
11.299	596+61	11.359	599+76	LT	3	8	315	105	12	23	315	
11.379	600+82	11.472	605+71	LT	3	8	489	163	19	36	489	
11.472	605+71	11.565	610+65	LT	3	8	494	165	19	36	494	
11.472	605+71	11.565	610+65	RT	3	8	494	165	19	36	494	
11.853	625+85	12.355	652+34	RT	3	8	2,649	883	102	194	2,649	
11.853	625+85	12.494	659+67	LT	3	8	3,382	1,127	130	248	3,382	
12.600	665+29	12.638	667+27	LT	3	8	198	66	3	15	198	
12.600	665+29	12.698	670+44	RT	3	8	515	172	7	38	515	
12.662	668+53	12.698	670+44	LT	3	8	191	64	2	14	191	
12.698	670+44	12.876	679+83	LT	3	8	939	313	36	69	939	
12.698	670+44	12.876	679+83	RT	3	8	939	313	36	69	939	
14.056	742+15	14.205	750+04	LT	3	8	789	263	30	58	789	
14.117	745+37	14.205	750+04	RT	3	8	467	156	18	34	467	
14.205	750+04	14.331	756+67	LT	3	8	663	221	25	49	663	
14.205	750+04	14.331	756+67	RT	3	8	663	221	25	49	663	
14.331	756+67	14.491	765+12	RT	3	8	845	282	32	62	845	
14.516	766+42	14.824	782+70	LT	3	8	1,628	543	62	119	1,628	
<b>TOTALS</b>							<b>1,628</b>	<b>5,222 SY</b>	<b>577 TONS</b>	<b>1,149 TONS</b>	<b>15,660 LF</b>	

**RESURFACING SUMMARY**

Begin		End		Width (FT)	Depth (IN)	Length (LF)	Asph. Pave. Mill & Text (Tons)	CL2 Asph Surf 0.38D PG64-22 (Tons)	CL2 Asph Surf 0.5B PG64-22 (Tons)	Asph. Material for Tack Non-Tracking (Tons)	Edgeline Rumble Strips (LF)	Comments
Milepoint	Station	Milepoint	Station									
9.584	506+04	13.447	710+00	23	1.00	20,396	40 *	3,154	0	14.3	38,752	* Includes 24 Tons for area near Bridge No. B00001N
13.469	711+15	14.205	750+04	23	1.00	3,889	8	602	0	2.7	7,389	
14.205	750+04	14.331	756+67	23	1.50	663	0	0	154	0.5	1,260	
14.331	756+67	15.657	826+69	23	1.00	7,002	8	1,082	0	4.9	13,304	
<b>TOTALS</b>							<b>56 TONS</b>	<b>4,838 TONS</b>	<b>154 TONS</b>	<b>22.5 TONS</b>	<b>60,705 LF</b>	

PIPE REPLACEMENT & EXTENSION SUMMARY

Milepoint	Station	Pipe Size, Type	Existing		Skew	Length (LF)	Remove Pipe (LF)		Pipe Extension Length (LF)		Class A Concrete for Intermediate Anchor/Collar (CU YD) <sup>3</sup>	Entrance Pipe 15" (LF)	Culvert Pipe 18" (LF)	Culvert Pipe 24" (LF)	Culvert Pipe 30" (LF)	Culvert Pipe 36" (LF)	Culvert Pipe 42" (LF)	Headwall or Drainage Box		Ditching & Shouldering (LF)		Channel Lining, C.I.II (TON)		Comments				
			Left Hdwl	Right Hdwl			Left	Right	Left	Right								Left	Right	Left	Right	Left	Right					
11.429	603+46	36" CMP			22.33° RT.	42																		6		Clean out pipe		
13.842	730+85	3 - 18" RCP	Triple Pipe Culvert Headwall	Triple Pipe Culvert Headwall	1.73° RT.	32 (each)	4 (each)		4 (each)		3.21		12														Clean out pipes	
14.189	749+20	24" RCP				34	4	4	4	9	3.18			13												42	36	Clean out pipe
<b>TOTALS:</b>								<b>20 LF</b>			<b>6.39 CU YD</b>	<b>0 LF</b>	<b>12 LF</b>	<b>13 LF</b>	<b>0 LF</b>	<b>0 LF</b>	<b>0 LF</b>					<b>0 LF</b>			<b>42 TON</b>			

Totals	
Remove Headwall	1 Each
Remove Pipe	20 LF
Culvert Pipe - 18 IN	12 LF
Culvert Pipe - 24 IN	13 LF
Concrete - Class A	6.39 CU YD
Headwall (18 IN Triple Pipe Culvert)	1 Each
Headwall (24 IN Standard Concrete)	1 Each
Headwall (Sloped & Mitered Concrete - For 24 IN Pipe)	1 Each
Headwall (Sloped & Mitered Concrete - For 36 IN Pipe)	1 Each
Channel Lining C.I.II	42 Ton
Clean Pipe Structure	5 Each

- NOTES:
1. These Pipe and Drainage Item quantities and locations are approximate and are intended to provide a basis for bid. Final locations, flow line elevations, grate elevations, and quantities will be determined by the Contractor and approved by the Engineer in the field.
  2. Clearing and grubbing necessary to install drainage items, as directed by the Engineer, will be considered part of Site Preparation, which is incidental to the Contract.
  3. See Standard Drawing RDX-060-04 for Intermediate Anchor details.
  4. All pipe extensions are to be of in-kind material.

ENTRANCE PIPE SUMMARY

Milepoint	Station	Pipe Size, Type	LT / RT	Remove Pipe (LF)	Length of Pipe (LF)			Proposed						Comments
					15"	18"	24"	TBB		Entrance Pavement		Asphalt		
					TBB		Concrete		Asphalt					
					Avg. Depth (IN)	Area (SQYD)	Avg. Depth (IN)	Area (SQYD)	Avg. Depth (IN)	Area (SQYD)				
1.1503	607+35	18" CMP	RT	37		40								
1.1543	609+45	18" CMP	RT	33	5	37								
<b>TOTALS:</b>				<b>70 LF</b>	<b>0 LF</b>	<b>77 LF</b>	<b>0 LF</b>	<b>25 TON</b>	<b>0 TON</b>	<b>0 TON</b>				

Totals		
Remove Pipe	70	LF
Entrance Pipe-15 IN	0	LF
Entrance Pipe-18 IN	77	LF
Entrance Pipe-24 IN	0	LF
Traffic Bound Base	25	Ton
Cem Conc Ent Pavement-8 IN	0	Ton
CL2 Asp Ph Base 1.00D PG64-22	0	Ton
CL2 Asp Ph Surf 0.5A PG64-22	0	Ton

**Ditching & Shouldering Summary**

**Union County**

**KY 130**

*The "Figure References" noted below refer to the Figure number within the Ditching & Shouldering Detail Sheet that is the closest representation of the intended Ditching & Shouldering.																
**The Estimated Volumes of Excavation and Embankment are provided for informational purposes ONLY. The Department gives no guarantee to the accuracy of the estimated volumes. The Bidder must draw his/her own conclusion. Payment will be based on the Linear Footage of Ditching & Shouldering performed, regardless of the accuracy of the estimated volumes of Excavation and Embankment.																
Side of Road	LOCATION				Length (LF)	Estimated Excavation Volume** (CU YD)	Estimated Embankment Volume** (CU YD)	Ditching & Shouldering Detail Sheet Figure Ref. *	Include DGA Wedge? (Yes/No)	DGA (TONS)	Asphalt Seal Coat (TON)	Asphalt Seal Aggregate (TON)	Channel Line Ditch, Fill Slope or Cut Slope? (Yes/No)	Channel Lining Class II (TONS)	Geotex. Fabric Class 2 (SQ YD)	Remarks
	Approx. BEGIN Station	Approx. BEGIN Milepoint	Approx. END Station	Approx. END Milepoint												
RT	525+67	9.956	536+36	10.158	1,069	119	158	Figure 9	No				No			W = 18". Maintain flowline at existing entrance pipes.
RT	539+44	10.217	541+29	10.252	185	21	27	Figure 9	No				No			W = 18". Maintain flowline at existing entrance pipes.
LT	540+95	10.245	543+36	10.291	241	0	54	Figure 5	Yes	10	0.13	1.01	Yes - Fill Slope	111	41	W = 18".
LT	558+64	10.580	560+04	10.607	140	26	10	Figure 8	No				No			W = 18". Maintain flowline at existing entrance pipes.
RT	559+10	10.589	560+53	10.616	143	26	11	Figure 9	No				No			W = 18". Maintain flowline at existing entrance pipes.
RT	566+32	10.726	568+14	10.760	182	34	20	Figure 9	No				No			W = 18".
RT	580+75	10.999	582+59	11.034	184	34	20	Figure 9	No				No			W = 18". Maintain flowline at existing entrance pipes.
RT	583+38	11.049	590+20	11.178	682	126	76	Figure 9	No				No			W = 18". Maintain flowline at existing entrance pipes.
RT	596+37	11.295	602+29	11.407	592	88	99	Figure 9	No				No			W = 18".
LT	596+61	11.299	599+76	11.359	315	23	23	Figure 9	No				No			W = 18".
LT	600+82	11.379	606+10	11.479	528	117	39	Figure 9	No				No			W = 18". Maintain flowline at existing entrance pipes.
RT	603+30	11.426	658+36	12.469	5,506	714	816	Figure 9	No				No			W = 18". Maintain flowline at existing entrance pipes.
LT	606+10	11.479	609+90	11.551	380	84	14	Figure 11	No				Yes - Cut Slope	127		W = 18". Maintain flowline at existing entrance pipes.

**Ditching & Shouldering Summary**

**Union County**

**KY 130**

\*The "Figure References" noted below refer to the Figure number within the Ditching & Shouldering Detail Sheet that is the closest representation of the intended Ditching & Shouldering.  
 \*\* The Estimated Volumes of Excavation and Embankment are provided for informational purposes ONLY. The Department gives no guarantee to the accuracy of the estimated volumes. The Bidder must draw his/her own conclusion. Payment will be based on the Linear Footage of Ditching & Shouldering performed, regardless of the accuracy of the Estimated Volumes of Excavation and Embankment.

Side of Road	LOCATION				Length (LF)	Estimated Excavation Volume** (CU YD)	Estimated Embankment Volume** (CU YD)	Ditching & Shouldering Detail Sheet Figure Ref. *	Include DGA Wedge? (Yes/No)	DGA (TONS)	Asphalt Seal Coat (TON)	Asphalt Seal Aggregate (TON)	Channel Line Ditch, Fill Slope or Cut Slope? (Yes/No)	Channel Lining Class II (TONS)	Geotex. Fabric Class 2 (SQ YD)	Remarks
	Approx. BEGIN Milepoint	Approx. END Milepoint	Approx. BEGIN Station	Approx. END Station												
LT	609+90	11.551	610+65	11.565	75	11	8	Figure 9	No				No			W = 18". Maintain flowline at existing entrance pipes.
LT	614+58	11.640	625+85	11.853	1,127	167	125	Figure 9	No				No			W = 18". Maintain flowline at existing entrance pipes.
LT	625+85	11.853	631+10	11.953	525	0	117	Figure 5	Yes	21	0.27	2.19	Yes - Fill Slope	197	88	W = 18". Maintain flowline at existing entrance pipes.
LT	631+10	11.953	659+67	12.494	2,857	423	476	Figure 9	No				No			W = 18". Maintain flowline at existing entrance pipes.
LT	663+34	12.563	667+27	12.638	393	44	51	Figure 9	No				No			W = 18".
RT	663+34	12.563	697+84	13.217	3,450	511	383	Figure 9	No				No			W = 18". Maintain flowline at existing entrance pipes.
LT	668+53	12.662	697+05	13.202	2,852	264	211	Figure 9	No				No			W = 18".
LT	715+50	13.551	724+05	13.713	855	127	111	Figure 9	No				No			W = 18".
RT	715+50	13.551	724+05	13.713	855	95	79	Figure 9	No				No			W = 18". Maintain flowline at existing entrance pipes.
LT	728+31	13.794	730+96	13.844	265	39	29	Figure 9	No				No			W = 18". Maintain flowline at existing entrance pipes.
LT	734+42	13.909	741+35	14.041	693	128	90	Figure 9	No				No			W = 18". Maintain flowline at existing entrance pipes.
LT	742+15	14.056	765+12	14.491	2,297	510	340	Figure 9	No				No			W = 18". Maintain flowline at existing entrance pipes.
RT	745+37	14.117	749+16	14.189	379	42	84	Figure 2	No				No			W = 18".
RT	749+16	14.189	754+00	14.280	484	54	108	Figure 9	No				No			W = 18". Maintain flowline at existing entrance pipes.
RT	754+00	14.280	757+65	14.349	365	0	81	Figure 5	Yes	14	0.19	1.53	Yes - Fill Slope	153	61	W = 18".

**Ditching & Shouldering Summary**

**Union County**

**KY 130**

* The "Figure References" noted below refer to the Figure number within the Ditching & Shouldering Detail Sheet that is the closest representation of the intended Ditching & Shouldering.																
** The Estimated Volumes of Excavation and Embankment are provided for informational purposes ONLY. The Department gives no guarantee to the accuracy of the estimated volumes. The Bidder must draw his/her own conclusion. Payment will be based on the Linear Footage of Ditching & Shouldering performed, regardless of the accuracy of the Estimated Volumes of Excavation and Embankment.																
Side of Road	Approx. BEGIN Station	Approx. BEGIN Milepoint	Approx. END Station	Approx. END Milepoint	Length (LF)	Estimated Excavation Volume** (CU YD)	Estimated Embankment Volume** (CU YD)	Ditching & Shouldering Detail Sheet Figure Ref. *	Include DGA Wedge? (Yes/No)	DGA (TONS)	Asphalt Seal Coat (TON)	Asphalt Seal Aggregate (TON)	Channel Line Ditch, Fill Slope or Cut Slope? (Yes/No)	Channel Lining Class II (TONS)	Geotex. Fabric Class 2 (SQ YD)	Remarks
RT	757+65	14.349	772+31	14.627	1,466	163	326	Figure 9	No					No		W = 18". Maintain flowline at existing entrance pipes.
LT	766+42	14.516	782+70	14.824	1,628	241	211	Figure 9	No					No		W = 18". Maintain flowline at existing entrance pipes.
RT	781+63	14.804	787+09	14.907	546	81	71	Figure 9	No					No		W = 18". Maintain flowline at existing entrance pipes.

**Summary of Items**

Item Description	Quantity	Unit	Material	Quantity	Unit	Material	Quantity	Unit	Material
Ditching & Shouldering	31,259	LF	Asphalt Seal Coat	0.6	TONS				
DGA	45	TONS	Asphalt Seal Aggregate	5	TONS				
			Channel Lining Class II	588	TONS				
			Geotextile Fabric Class 2	190	SQ YD				

**Guardrail Summary**

**County: UNION**

**Route: KY 130**

**Notes:** Begin/End Milepoints are estimated to include the entire length of the Rail AND the End Treatments. The Engineer may adjust the proposed guardrail termini to ensure proper installation of the guardrail system.  
Existing guardrail removed from the project shall be delivered by the Contractor to the KYTC Maintenance facility in Frankfort.

Proposed Guardrail to be Constructed										Existing Guardrail to be Removed					
Side of Road	Proposed BEGINNING Treatment	Approx. BEGIN Station	Approx. BEGIN Milepoint	Approx. END Station	Approx. END Milepoint	Proposed ENDING Treatment	Proposed Length (LF)	Number of Radius Rail	Remarks	Side of Road	Approx. BEGIN Station	Approx. BEGIN Milepoint	Approx. END Station	Approx. END Milepoint	Existing Length (LF)
RT	Type 1	658+34	12.469	658+84	12.478		0.00	0	Remove Existing End Treatment Type 7 & Replace with New End Treatment Type 1						
LT		662+84	12.554	663+34	12.563	Type 1	0.00	0	Remove Existing End Treatment Type 7 & Replace with New End Treatment Type 1			0.000	0.000	0.00	
RT		662+84	12.554	663+34	12.563	Type 1	0.00	0	Remove Existing End Treatment Type 7 & Replace with New End Treatment Type 1			0.000	0.000	0.00	
LT	Type 1	707+05	13.391	710+05	13.448	Connector Type D	250.00	0	New End Treatment Type 1, 250 FT of Single Face, Connector Type D to Existing Bridge			0.000	0.000	0.00	
RT	Type 1	707+05	13.391	710+05	13.448	Connector Type D	250.00	0	New End Treatment Type 1, 250 FT of Single Face, Connector Type D to Existing Bridge			0.000	0.000	0.00	
LT	Connector Type D	711+10	13.468	713+10	13.506	Type 1	150.00	0	Connector Type D to Existing Bridge, 150 FT of Single Face, New End Treatment Type 1			0.000	0.000	0.00	
RT	Connector Type D	711+10	13.468	713+10	13.506	Type 1	150.00	0	Connector Type D to Existing Bridge, 150 FT of Single Face, New End Treatment Type 1			0.000	0.000	0.00	
RT	Type 1	750+65	14.217	752+41	14.250	Terminal Section 1	141.25	1	Remove Existing Guardrail & Construct New Terminal Section Type 1, 403.75 FT of Single Face (Includes Radius Rail), Luciol Systems Advanced Delineation, New Terminal Section Type 1			0.000	0.000	0.00	
RT	Terminal Section 1	752+68	14.255	757+08	14.339	Type 1	403.75	1	Remove Existing Guardrail & Construct New Terminal Section Type 1, 403.75 FT of Single Face (Includes Radius Rail), Luciol Systems Advanced Delineation, New End Treatment Type 1	RT	753+35	14.268	755+26	14.304	200.00

**Summary of Items**

Item Description	Quantity	Unit	Notes
Guardrail-Steel W/Beam-S Face	1,345.00	LF	
Remove Guardrail	200.00	LF	
End Treatment Type 1	9	EACH	
End Treatment Type 2A	0	EACH	
End Treatment Type 3	0	EACH	
End Treatment Type 4A	0	EACH	
Remove End Treatment	3	EACH	
Terminal Section No. 1	2	EACH	
Luciol Systems Advanced Delineation	44	EACH	
Delineator for Guardrail B/W	16	EACH	
GR Connector to Bridge End Type A	0	EACH	
GR Connector to Bridge End Type A-1	0	EACH	
GR Connector to Bridge End Type C	4	EACH	
GR Connector to Bridge End Type D	0	TONS	
DGA	0	TONS	
Asphalt Seal Coat	0.00	TONS	
Asphalt Seal Aggregate	0.00	TONS	
Guardrail-Bridge Case II	0	LF	

Assembly ID	LT / RT	Approx Offset (FT)	Approx Station	Approx Milepoint	Facing Traffic Traveling	MUTCD Code	Sign Description	Sign Text / Remarks	Sign Dimensions (in x in)	Union County		SBM Alum Sheet Signs 0.080 IN (SQ FT)	SBM Alum Sheet Signs 0.125 IN (SQ FT)	# of Sign Posts	Estimated Length of 2" Post (FT)	TOTAL Estimated Sign Post Length (LF)	Barcode Sign Inv. (EACH)	
										Text/ Symbol Color	Background Color							Sheeting Type
1	LT	15	524+32	9.930	SB	W2-1	Cross Road		30 x 30	Black	Yellow	Xi	6.25		1	13	13	1
						W13-1P	XX MPH (Advisory Speed)	25	18 x 18	Black	FL Yellow	Xi	2.25					1
2	RT	15	525+45	9.952	NB	W2-2L	Side Road Left		30 x 30	Black	Yellow	Xi	6.25		1	11	11	1
3	LT	15	527+00	9.981	NB	W14-3	No Passing Zone		48 x 48 x 36	Black	Yellow	Xi	5.56		1	11	11	1
4	RT	15	527+00	9.981	SB	W14-3	No Passing Zone		48 x 48 x 36	Black	Yellow	Xi	5.56		1	11	11	1
5	LT	15	527+52	9.991	SB	R2-1	Speed Limit XX	35	24 x 30	Black	White	Xi	5.00		1	10	10	1
6	RT	15	527+52	9.991	NB	R2-1	Speed Limit XX	55	24 x 30	Black	White	Xi	5.00		1	10	10	1
7	RT	15	528+00	10.000	NB	D10-2	Mile Marker (2 digit)	10	10 x 27	White	Green	Xi	1.88		1	10	10	1
						D10-2	Mile Marker (2 digit)	10	10 x 27	White	Green	Xi	1.88		1	10	10	1
8	LT	15	529+57	10.030	SB	W3-5	Speed Limit XX Ahead	35	36 x 36	White &	Yellow	Xi	9.00		1	12	12	1
9	RT	15	541+00	10.246	SB	W14-3	No Passing Zone		48 x 48 x 36	Black	Yellow	Xi	5.56		1	11	11	1
10	LT	15	543+49	10.293	NB	OM3-L	Object Marker Type 3 Left		12 x 36	Black	Yellow	Xi	3.00		1	10	10	1
11	RT	15	543+49	10.293	NB	OM3-R	Object Marker Type 3 Right		12 x 36	Black	Yellow	Xi	3.00		1	10	10	1
12	LT	15	543+68	10.297	SB	OM3-R	Object Marker Type 3 Right		12 x 36	Black	Yellow	Xi	3.00		1	10	10	1
13	RT	15	543+68	10.297	SB	OM3-L	Object Marker Type 3 Left		12 x 36	Black	Yellow	Xi	3.00		1	10	10	1
14	LT	15	545+00	10.322	NB	W14-3	No Passing Zone		48 x 48 x 36	Black	Yellow	Xi	5.56		1	11	11	1
15	RT	15	545+98	10.341	NB	W7-6	Hill Blocks View		30 x 30	Black	Yellow	Xi	6.25		1	13	13	1
						W13-1P	XX MPH (Advisory Speed)	45	18 x 18	Black	FL Yellow	Xi	2.25					1
16	LT	15	556+71	10.544	SB	S3-1	School Bus Stop Ahead		36 x 36	Black	FL Yellow	Xi	9.00		1	12	12	1
17	RT	15	561+00	10.625	SB	W14-3	No Passing Zone		48 x 48 x 36	Black	Yellow	Xi	5.56		1	11	11	1
18	LT	15	562+85	10.660	SB	W7-6	Hill Blocks View		30 x 30	Black	Yellow	Xi	6.25		1	13	13	1
						W13-1P	XX MPH (Advisory Speed)	45	18 x 18	Black	FL Yellow	Xi	2.25					1
19	LT	15	567+94	10.756	NB	OM3-L	Object Marker Type 3 Left		12 x 36	Black	Yellow	Xi	3.00		1	10	10	1
20	LT	15	568+22	10.762	SB	OM3-R	Object Marker Type 3 Right		12 x 36	Black	Yellow	Xi	3.00		1	10	10	1
21	RT	15	568+31	10.763	NB	OM3-R	Object Marker Type 3 Right		12 x 36	Black	Yellow	Xi	3.00		1	10	10	1
22	RT	15	568+55	10.768	SB	OM3-L	Object Marker Type 3 Left		12 x 36	Black	Yellow	Xi	3.00		1	10	10	1
23	RT	15	580+80	11.000	NB	D10-2	Mile Marker (2 digit)	11	10 x 27	White	Green	Xi	1.88		1	10	10	1
						D10-2	Mile Marker (2 digit)	11	10 x 27	White	Green	Xi	1.88		1	10	10	1
24	LT	15	582+30	11.028	NB	OM3-L	Object Marker Type 3 Left		12 x 36	Black	Yellow	Xi	3.00		1	10	10	1
25	LT	15	582+59	11.034	SB	OM3-R	Object Marker Type 3 Right		12 x 36	Black	Yellow	Xi	3.00		1	10	10	1
26	RT	15	582+63	11.035	NB	OM3-R	Object Marker Type 3 Right		12 x 36	Black	Yellow	Xi	3.00		1	10	10	1
27	RT	15	582+92	11.040	SB	OM3-L	Object Marker Type 3 Left		12 x 36	Black	Yellow	Xi	3.00		1	10	10	1
28	LT	15	591+00	11.193	NB	W14-3	No Passing Zone		48 x 48 x 36	Black	Yellow	Xi	5.56		1	11	11	1
29	RT	15	596+75	11.302	NB	W2-7L	Offset Side Roads Left		30 x 30	Black	Yellow	Xi	6.25		1	11	11	1
						W1-2L	Left Curve		30 x 30	Black	FL Yellow	Xi	6.25		1	13	13	1
30	RT	15	604+76	11.454	NB	W13-1P	XX MPH (Advisory Speed)	***	18 x 18	Black	FL Yellow	Xi	2.25		1	11	11	1
						W2-7L	Offset Side Roads Left		30 x 30	Black	Yellow	Xi	6.25		1	11	11	1
31	LT	15	605+44	11.467	SB	W1-8R	Right Chevron		18 x 24	Black	FL Yellow	Xi	3.00		1	9	9	1
32	RT	15	606+76	11.492	SB	W1-8R	Right Chevron		18 x 24	Black	FL Yellow	Xi	3.00		1	9	9	1
33	RT	15	607+61	11.508	NB	W1-8L	Left Chevron		18 x 24	Black	FL Yellow	Xi	3.00		1	9	9	1
						W1-8R	Right Chevron		18 x 24	Black	FL Yellow	Xi	3.00		1	9	9	1
34	RT	15	608+73	11.529	NB	W1-8L	Left Chevron		18 x 24	Black	FL Yellow	Xi	3.00		1	9	9	1
						W1-8R	Right Chevron		18 x 24	Black	FL Yellow	Xi	3.00		1	9	9	1
35	RT	15	609+60	11.545	NB	W1-8L	Left Chevron		18 x 24	Black	FL Yellow	Xi	3.00		1	9	9	1
						W1-2R	Right Curve		30 x 30	Black	FL Yellow	Xi	6.25		1	13	13	1
36	LT	15	611+59	11.583	SB	W13-1P	XX MPH (Advisory Speed)	***	18 x 18	Black	FL Yellow	Xi	2.25		1	11	11	1
						W14-3	No Passing Zone		48 x 48 x 36	Black	Yellow	Xi	5.56		1	11	11	1
37	RT	15	618+99	11.723	SB	OM3-L	Object Marker Type 3 Left		12 x 36	Black	Yellow	Xi	3.00		1	10	10	1
38	RT	15	625+95	11.855	NB	OM3-R	Object Marker Type 3 Right		12 x 36	Black	Yellow	Xi	3.00		1	10	10	1
39	RT	15	626+10	11.858	NB	OM3-R	Object Marker Type 3 Right		12 x 36	Black	Yellow	Xi	3.00		1	10	10	1
40	LT	15	626+18	11.859	SB	OM3-R	Object Marker Type 3 Right		12 x 36	Black	Yellow	Xi	3.00		1	10	10	1
41	RT	15	626+38	11.863	SB	OM3-L	Object Marker Type 3 Left		12 x 36	Black	Yellow	Xi	3.00		1	10	10	1

Sign Summary

Union County

KY 130

SIGN LOCATION

SHEETING

SBM Alum

SBM Alum

# of Sign Posts

Estimated Length of Sign Post (FT)

TOTAL Estimated Sign Post Length (LF)

Barcode Sign Inv. (EACH)

Assembly ID	LT / RT	Approx Offset (FT)	Approx Station	Approx. Milepoint	Facing Traffic Traveling	MUTCD Code	Sign Description	Sign Text / Remarks	Sign Dimensions (in x in)	Text/ Symbol Color	Background Color	Sheeting Type	SBM Alum Sheet Signs 0.080 IN (SQ FT)	SBM Alum Sheet Signs 0.125 IN (SQ FT)	# of Sign Posts	Estimated Length of Sign Post (FT)	TOTAL Estimated Sign Post Length (LF)	Barcode Sign Inv. (EACH)
42	RT	15	633+60	12.000	NB	D10-2	Mile Marker (2 digit)	12	10 x 27	White	Green	XX	1.88		1	10	10	1
					SB	D10-2	Mile Marker (2 digit)	12	10 x 27	White	Green	XX	1.88					
43	LT	15	651+00	12.330	NB	W14-3	No Passing Zone	48 x 48 x 36	48 x 48 x 36	Black	Yellow	XX		5.56	1	11	11	1
					NB	W14-3	No Passing Zone	48 x 48 x 36	48 x 48 x 36	Black	Yellow	XX		5.56	1	11	11	1
44	RT	15	653+98	12.386	NB	M2-1	Junction	948	21 x 15	Black	White	XX	2.19		1	11	11	1
					NB	M1-5a	State Route Sign (3 or 4)	948	30 x 24	Black	White	XX	5.00		1	11	11	1
45	LT	15	658+71	12.476	SB	M3-3	South	130	24 x 12	Black	White	XX	2.00		1	10	10	1
					SB	M1-5a	State Route Sign (3 or 4)	130	30 x 24	Black	White	XX	5.00		1	10	10	1
46	RT	15	659+82	12.497	NB	M1-5a	State Route Sign (3 or 4)	948	30 x 24	Black	White	XX	5.00		1	11	11	1
					NB	M6-1L	Left Arrow	948	21 x 15	Black	White	XX	2.19		1	11	11	1
47	RT	15	660+32	12.506	KY 948	M1-5a	State Route Sign (3 or 4)	130	30 x 24	Black	White	XX	5.00		1	11	11	1
					KY 948	M6-4	Horizontal Double Arrow	948	21 x 15	Black	White	XX	2.19		1	11	11	1
48	LT	15	661+37	12.526	SB	M1-5a	State Route Sign (3 or 4)	948	30 x 24	Black	White	XX	5.00		1	11	11	1
					SB	M6-1R	Right Arrow	948	21 x 15	Black	White	XX	2.19		1	11	11	1
49	RT	15	662+28	12.543	NB	M2-1	Junction	666	21 x 15	Black	White	XX	2.19		1	11	11	1
					NB	M1-5a	State Route Sign (3 or 4)	666	30 x 24	Black	White	XX	5.00		1	11	11	1
50	RT	15	664+34	12.582	NB	W1-2R	Right Curve	666	30 x 30	Black	FL Yellow	XX	6.25		1	13	13	1
					NB	W1-3-1P	XX MPH (Advisory Speed)	666	18 x 18	Black	FL Yellow	XX	2.25		1	13	13	1
51	LT	15	665+91	12.612	SB	M2-1	Junction	948	21 x 15	Black	White	XX	2.19		1	11	11	1
					SB	M1-5a	State Route Sign (3 or 4)	948	30 x 24	Black	White	XX	5.00		1	11	11	1
52	LT	15	667+30	12.638	NB	W1-8R	Right Chevron	18 x 24	18 x 24	Black	FL Yellow	XX	3.00		1	9	9	1
					SB	W1-8L	Left Chevron	18 x 24	18 x 24	Black	FL Yellow	XX	3.00		1	9	9	1
53	RT	15	667+35	12.639	NB	M1-5a	State Route Sign (3 or 4)	666	30 x 24	Black	White	XX	5.00		1	11	11	1
					NB	M6-1L	Left Arrow	666	21 x 15	Black	White	XX	2.19		1	11	11	1
54	RT	15	667+70	12.646	KY 666	M1-5a	State Route Sign (3 or 4)	130	30 x 24	Black	White	XX	5.00		1	11	11	1
					KY 666	M6-4	Horizontal Double Arrow	666	21 x 15	Black	White	XX	2.19		1	11	11	1
55	LT	15	668+48	12.661	SB	M1-5a	State Route Sign (3 or 4)	666	30 x 24	Black	White	XX	5.00		1	11	11	1
					SB	M6-1R	Right Arrow	666	21 x 15	Black	White	XX	2.19		1	11	11	1
56	LT	15	669+39	12.678	NB	W1-8R	Right Chevron	18 x 24	18 x 24	Black	FL Yellow	XX	3.00		1	9	9	1
					NB	M3-1	North	24 x 12	24 x 12	Black	White	XX	2.00		1	10	10	1
57	RT	15	669+76	12.685	NB	M1-5a	State Route Sign (3 or 4)	130	30 x 24	Black	White	XX	5.00		1	10	10	1
					NB	M1-2L	Left Curve	30 x 30	30 x 30	Black	FL Yellow	XX	6.25		1	13	13	1
58	LT	15	671+40	12.716	SB	W1-3-1P	XX MPH (Advisory Speed)	***	18 x 18	Black	FL Yellow	XX	2.25		1	13	13	1
					SB	M2-1	Junction	666	21 x 15	Black	White	XX	2.19		1	11	11	1
59	LT	15	674+59	12.776	SB	M1-5a	State Route Sign (3 or 4)	666	30 x 24	Black	White	XX	5.00		1	11	11	1
					SB	W14-3	No Passing Zone	48 x 48 x 36	48 x 48 x 36	Black	Yellow	XX	5.56		1	11	11	1
60	RT	15	679+00	12.860	SB	D10-2	Mile Marker (2 digit)	13	10 x 27	White	Green	XX	1.88		1	10	10	1
					SB	D10-2	Mile Marker (2 digit)	13	10 x 27	White	Green	XX	1.88		1	10	10	1
61	RT	15	686+39	13.000	NB	W14-3	No Passing Zone	48 x 48 x 36	48 x 48 x 36	Black	Yellow	XX	5.56		1	11	11	1
					SB	W14-3	No Passing Zone	48 x 48 x 36	48 x 48 x 36	Black	Yellow	XX	5.56		1	11	11	1
62	LT	15	715+50	13.551	NB	W14-3	No Passing Zone	48 x 48 x 36	48 x 48 x 36	Black	Yellow	XX	5.56		1	11	11	1
					SB	W14-3	No Passing Zone	48 x 48 x 36	48 x 48 x 36	Black	Yellow	XX	5.56		1	11	11	1
63	RT	15	728+00	13.788	NB	OM3-R	Object Marker Type 3 Right	3.00	12 x 36	Black	Yellow	XX	3.00		1	10	10	1
					NB	OM3-L	Object Marker Type 3 Left	3.00	12 x 36	Black	Yellow	XX	3.00		1	10	10	1
64	RT	15	730+75	13.840	NB	OM3-L	Object Marker Type 3 Left	3.00	12 x 36	Black	Yellow	XX	3.00		1	10	10	1
					SB	OM3-1	Object Marker Type 3 Left	3.00	12 x 36	Black	Yellow	XX	3.00		1	10	10	1
66	RT	15	730+94	13.844	SB	W14-3	No Passing Zone	48 x 48 x 36	48 x 48 x 36	Black	Yellow	XX	5.56		1	14	14	1
					SB	OM3-R	Object Marker Type 3 Right	3.00	12 x 36	Black	Yellow	XX	3.00		1	14	14	1
67	LT	15	731+00	13.845	SB	M2-1	Junction	141	21 x 15	Black	White	XX	2.19		1	11	11	1
					NB	M1-5a	State Route Sign (3 or 4)	141	30 x 24	Black	White	XX	5.00		1	11	11	1
68	RT	15	735+59	13.932	NB	D10-2	Mile Marker (2 digit)	14	10 x 27	White	Green	XX	1.88		1	10	10	1
					NB	D10-2	Mile Marker (2 digit)	14	10 x 27	White	Green	XX	1.88		1	10	10	1
69	RT	15	739+18	14.000	SB	D10-2	Mile Marker (2 digit)	14	10 x 27	White	Green	XX	1.88		1	10	10	1

Sign Summary

Union County

KY 130

Assembly ID	LT / RT	Approx Offset (FT)	Approx Station	Approx. Milepoint	Facing Traffic Traveling	MUTCD Code	Sign Description	Sign Text / Remarks	Sign Dimensions (in x in)	SHEETING			SBM Alum Sheet Signs 0.080 IN (SQ FT)	SBM Alum Sheet Signs 0.125 IN (SQ FT)	# of Sign Posts	Estimated Length of 2" Post (FT)	TOTAL Estimated Sign Post Length (LF)	Barcode Sign Inv. (EACH)
										Text/ Symbol Color	Background Color	Sheeting Type						
70	LT	15	740+34	14.022	SB	M3-3	South		24 x 12	Black	White	White	2.00		1	10	10	1
						M1-5a	State Route Sign (3 or 4)	130	30 x 24	Black	White	White	5.00					1
						M1-5b	State Route Sign (3 or 4)	141	30 x 24	Black	White	White	5.00		1	11	11	1
						M6-1R	Right Arrow		21 x 15	Black	White	White	2.19					1
71	RT	15	740+81	14.030	NB	M3-1	North		24 x 12	Black	White	White	2.00		1	10	10	1
						M1-5a	State Route Sign (3 or 4)	130	30 x 24	Black	White	White	5.00					1
						M1-5b	State Route Sign (3 or 4)	141	30 x 24	Black	White	White	5.00		1	11	11	1
						M6-1L	Left Arrow		21 x 15	Black	White	White	2.19					1
72	RT	15	743+74	14.086	NB	M1-4R	Right Reverse Curve	***	18 x 18	Black	FL Yellow	FL Yellow	2.25		1	13	13	1
						M1-5a	State Route Sign (3 or 4)	130	30 x 24	Black	White	White	5.00					1
						M1-5b	State Route Sign (3 or 4)	141	30 x 24	Black	White	White	5.00		1	11	11	1
						M6-1L	Left Arrow		21 x 15	Black	White	White	2.19					1
73	LT	15	743+85	14.088	SB	M1-4R	Right Reverse Curve	***	18 x 18	Black	FL Yellow	FL Yellow	2.25		1	13	13	1
						M1-5a	State Route Sign (3 or 4)	141	30 x 24	Black	White	White	5.00					1
						M1-5b	State Route Sign (3 or 4)	141	30 x 24	Black	White	White	5.00		1	11	11	1
						M2-1	Junction		21 x 15	Black	White	White	2.19					1
						M1-5a	State Route Sign (3 or 4)	141	30 x 24	Black	FL Yellow	FL Yellow	2.25		1	13	13	1
74	RT	15	748+08	14.168	NB	M1-4R	Right Reverse Curve	***	18 x 18	Black	FL Yellow	FL Yellow	2.25		1	13	13	1
						M1-5a	State Route Sign (3 or 4)	141	30 x 24	Black	White	White	5.00					1
						M1-5b	State Route Sign (3 or 4)	141	30 x 24	Black	White	White	5.00		1	11	11	1
75	LT	15	748+95	14.185	SB	M1-4R	Right Reverse Curve	***	18 x 18	Black	FL Yellow	FL Yellow	2.25		1	13	13	1
						M1-5a	State Route Sign (3 or 4)	141	30 x 24	Black	White	White	5.00					1
						M1-5b	State Route Sign (3 or 4)	141	30 x 24	Black	White	White	5.00		1	11	11	1
76	LT	15	751+40	14.231	SB	M1-2L	Left Curve	***	30 x 30	Black	FL Yellow	FL Yellow	9.00		1	11	11	1
						M1-2L	Left Curve		30 x 30	Black	FL Yellow	FL Yellow	9.00					1
						M1-2L	Left Curve		30 x 30	Black	FL Yellow	FL Yellow	9.00		1	12	12	1
77	RT	15	752+42	14.250	NB	M1-2L	Left Curve	***	36 x 36	Black	FL Yellow	FL Yellow	9.00		1	12	12	1
						M1-8L	Left Chevron		18 x 24	Black	FL Yellow	FL Yellow	3.00					1
						M1-8R	Right Chevron		18 x 24	Black	FL Yellow	FL Yellow	3.00		1	9	9	1
78	RT	15	753+27	14.266	SB	M1-8L	Left Chevron		18 x 24	Black	FL Yellow	FL Yellow	3.00					1
						M1-8R	Right Chevron		18 x 24	Black	FL Yellow	FL Yellow	3.00		1	9	9	1
79	RT	15	753+90	14.278	NB	M1-8R	Right Chevron		18 x 24	Black	FL Yellow	FL Yellow	3.00					1
						M1-8L	Left Chevron		18 x 24	Black	FL Yellow	FL Yellow	3.00		1	9	9	1
80	RT	15	754+52	14.290	NB	M1-8R	Right Chevron		18 x 24	Black	FL Yellow	FL Yellow	3.00					1
						M1-2aR	Right Curve XX	***	30 x 30	Black	FL Yellow	FL Yellow	9.00		1	12	12	1
						M1-4R	Right Reverse Curve	***	30 x 30	Black	FL Yellow	FL Yellow	9.00		1	13	13	1
81	LT	15	755+22	14.303	SB	M1-3-1P	Right Reverse Curve	***	18 x 18	Black	FL Yellow	FL Yellow	2.25		1	11	11	1
						M1-4-3	No Passing Zone		48 x 48 x 36	Black	Yellow	Yellow	5.56		1	11	11	1
						M1-4-3	No Passing Zone		48 x 48 x 36	Black	Yellow	Yellow	5.56		1	11	11	1
82	RT	15	757+21	14.341	NB	M1-3-1P	Right Reverse Curve	***	18 x 18	Black	FL Yellow	FL Yellow	2.25		1	11	11	1
						M1-2L	Left Curve		30 x 30	Black	FL Yellow	FL Yellow	3.00					1
						M1-2L	Left Curve		30 x 30	Black	FL Yellow	FL Yellow	3.00		1	13	13	1
83	RT	15	765+00	14.489	SB	M1-3-1P	Right Reverse Curve	***	18 x 18	Black	FL Yellow	FL Yellow	2.25		1	11	11	1
						M1-3-1P	Right Reverse Curve		18 x 18	Black	FL Yellow	FL Yellow	2.25		1	13	13	1
84	LT	15	781+00	14.792	NB	M1-3-1P	Right Reverse Curve	***	18 x 18	Black	FL Yellow	FL Yellow	2.25		1	11	11	1
						M1-3-1P	Right Reverse Curve		18 x 18	Black	FL Yellow	FL Yellow	2.25		1	12	12	1
85	RT	15	785+27	14.873	NB	M1-3-1P	Right Reverse Curve	***	18 x 18	Black	FL Yellow	FL Yellow	2.25		1	11	11	1
						M1-3-1P	Right Reverse Curve		18 x 18	Black	FL Yellow	FL Yellow	2.25		1	12	12	1
86	RT	15	786+91	14.904	NB	M1-3-1P	Right Reverse Curve	***	18 x 18	Black	FL Yellow	FL Yellow	2.25		1	11	11	1
						M1-3-1P	Right Reverse Curve		18 x 18	Black	FL Yellow	FL Yellow	2.25		1	12	12	1
87	LT	15	788+90	14.941	SB	M1-3-1P	Right Reverse Curve	***	18 x 18	Black	FL Yellow	FL Yellow	2.25		1	11	11	1
						M1-3-1P	Right Reverse Curve		18 x 18	Black	FL Yellow	FL Yellow	2.25		1	12	12	1
88	LT	15	788+90	14.941	SB	M1-3-1P	Right Reverse Curve	***	18 x 18	Black	FL Yellow	FL Yellow	2.25		1	11	11	1
						M1-3-1P	Right Reverse Curve		18 x 18	Black	FL Yellow	FL Yellow	2.25		1	12	12	1
89	LT	15	790+63	14.974	SB	M1-2R	Right Curve		30 x 30	Black	FL Yellow	FL Yellow	6.25		1	11	11	1
						M1-2R	Right Curve		30 x 30	Black	FL Yellow	FL Yellow	6.25		1	11	11	1
90	RT	15	791+30	14.987	NB	M1-2L	Left Curve		30 x 30	Black	Yellow	Yellow	6.25		1	11	11	1
						M1-2L	Left Curve		30 x 30	Black	Yellow	Yellow	6.25		1	11	11	1
91	RT	15	792+00	15.000	NB	M1-2L	Left Curve		30 x 30	Black	Green	Green	1.88		1	10	10	1
						M1-2L	Left Curve		30 x 30	Black	Green	Green	1.88		1	10	10	1

Summary of Items			
SBM Alum Sheet Signs 0.080 INCH	446.63	SQ FT	
SBM Alum Sheet Signs 0.125 INCH	77.84	SQ FT	
Barcode Sign Inventory	133	EACH	
Remove Sign	73	EACH	

Summary of Items			
Steel Post - Type 1	978	LF	
GMSS Type D	0	EACH	
GMSS Type D (Surface Mount)	0	EACH	
Class A Concrete for Signs	0	CUYD	

\*\*\* Advisory Speed to be determined by Engineer by Ball Banking.

Remove Sign Summary					
Approx. Location		Sign Details	Approx. Location		Sign Details
Station	LT / RT		Station	LT / RT	
520+82	RT	Side Road Left	675+12	LT	Left Curve w/ Adv. Speed 40 MPH
521+74	RT	Speed Limit 35	676+38	RT	No Passing Zone
525+56	LT	Cross Road w/ Adv. Speed 25 MPH	684+88	RT	Mile Point Marker 13
526+45	LT	No Passing Zone	700+90	LT	No Passing Zone
527+41	RT	Speed Limit 55	709+97	RT	Type 3 Object Marker
527+44	LT	Speed Limit 35	709+99	LT	Type 3 Object Marker
527+50	RT	No Passing Zone	711+19	RT	Type 3 Object Marker
528+00	RT	Mile Point Marker 10	711+20	LT	Type 3 Object Marker
532+70	LT	Reduced Speed Limit Ahead 35	720+13	RT	No Passing Zone
541+58	RT	No Passing Zone	720+74	RT	Congested Area w/ Adv. Speed 45 MPH
543+46	RT	Object Marker	728+04	RT	No Passing Zone
543+71	LT	Object Marker	730+74	RT	Object Marker
544+49	LT	No Passing Zone	730+85	LT	No Passing Zone
556+71	LT	School Bus Stop Ahead	730+97	LT	Object Marker
561+68	RT	No Passing Zone	738+09	RT	Mile Point Marker 14
567+94	LT	Type 3 Object Marker	739+25	LT	SOUTH w/ KY 130
568+22	LT	Type 3 Object Marker	741+02	RT	NORTH w/ KY 130 w/ Up Arrow SOUTH w/ KY 141 w/ Right Arrow
568+31	RT	Type 3 Object Marker	743+79	LT	SOUTH w/ KY 141 w/ Up-Left Arrow w/ Slow Congested Area SOUTH w/ KY 130 w/ Up Arrow
568+55	RT	Type 3 Object Marker	745+87	RT	NORTH w/ KY 130
582+30	LT	Type 3 Object Marker	747+93	RT	Left Curve w/ Adv. Speed 35 MPH
582+59	LT	Type 3 Object Marker	747+95	LT	Congested Area w/ Adv. Speed 45 MPH
582+63	RT	Type 3 Object Marker	753+10	RT	Chevron
582+92	RT	Type 3 Object Marker	753+65	RT	Chevron
601+11	LT	No Passing Zone	753+91	RT	Single Arrow
616+19	RT	No Passing Zone	754+43	RT	Chevron
626+10	RT	Object Marker	755+03	RT	Chevron
626+20	LT	Object Marker	759+28	LT	Right Curve w/ Adv. Speed 35 MPH
633+42	RT	Mile Point Marker 12	760+90	LT	No Passing Zone
650+31	LT	No Passing Zone	762+93	RT	No Passing Zone
655+96	RT	JCT w/ KY 948	774+14	LT	No Passing Zone
656+70	LT	SOUTH w/ KY 130	774+44	RT	No Passing Zone
659+91	RT	SOUTH w/ KY 948 w/ Left Arrow	787+08	RT	Reduced Speed Limit Ahead 35
660+58	LT	SOUTH w/ KY 948 w/ Right Arrow	788+87	RT	Speed Limit 35
661+12	LT	Type 3 Object Marker	788+91	LT	Speed Limit 55
662+92	RT	JCT w/ KY 666	792+92	RT	Mile Point Marker 15
663+52	RT	Right Curve w/ Adv. Speed 40 MPH	794+99	LT	Right Curve w/ Adv. Speed 35 MPH
667+34	RT	WEST w/ KY 666 w/ Left Arrow			
668+47	LT	WEST w/ KY 666 w/ Right Arrow			
673+95	LT	JCT w/ KY 666			

COUNTY OF	ITEM NO.
UNION	2-9009.00

# SHOULDER WIDENING DETAIL

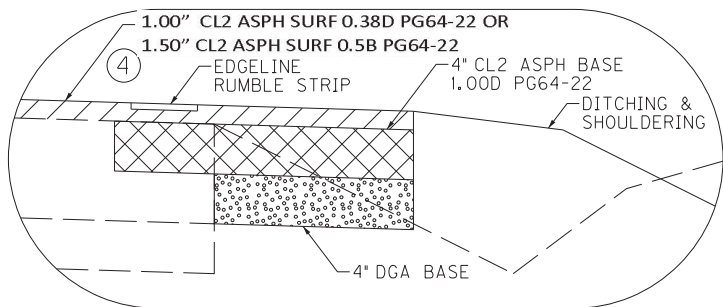
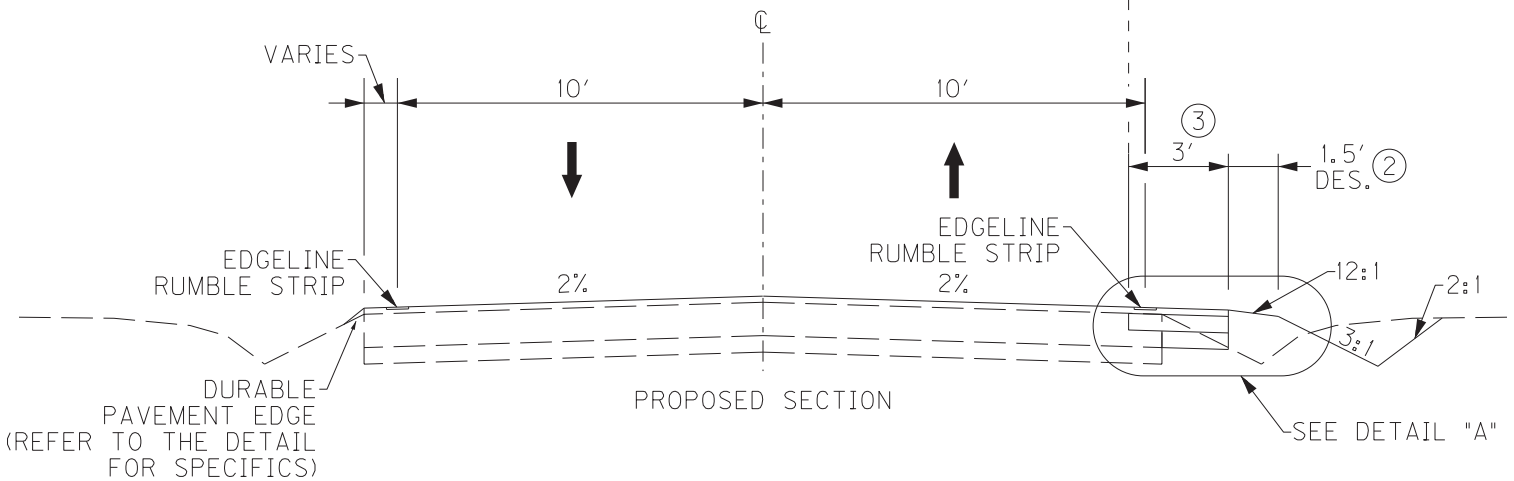
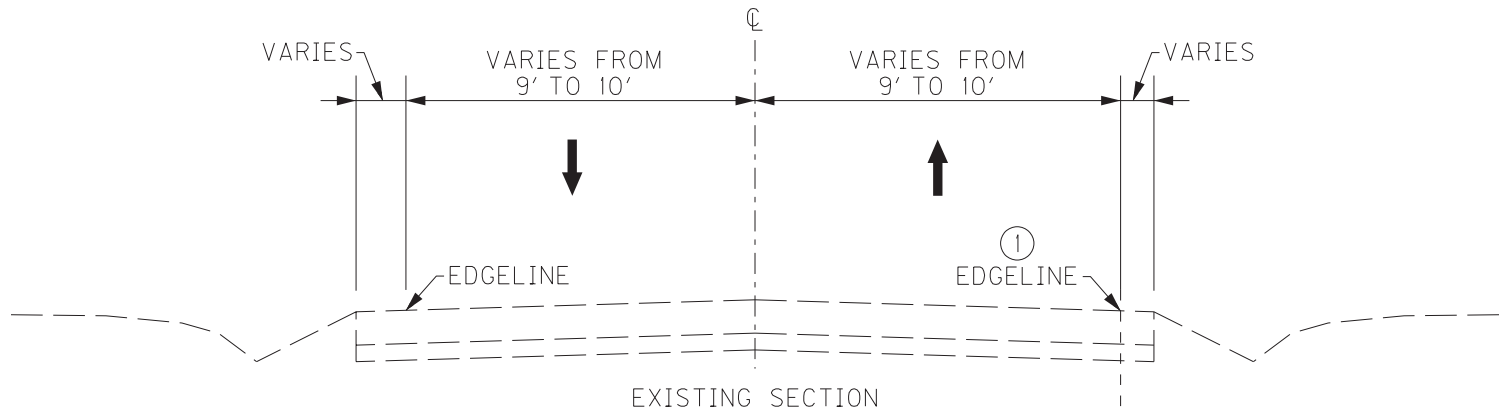

NOTES:

- ① SHOULDER MILLING/TRENCHING IS TO BE FROM THE EXISTING EDGE LINE.
- ② VARY EARTH SHOULDER WIDTH AS DIRECTED BY THE ENGINEER TO AVOID CONFLICTS WITH ROADSIDE FEATURES AND UTILITIES.
- ③ ADJUST SHOULDER GRADE AS DIRECTED BY THE ENGINEER (\*4% MAX.)
- ④ REFER TO THE RESURFACING SUMMARY FOR LOCATIONS OF EACH MIX.

KY 130  
 SHOULDER WIDENING DETAIL

COUNTY OF	ITEM NO.
UNION	2-9009.00

# SUPERELEVATION IMPROVEMENT DETAIL

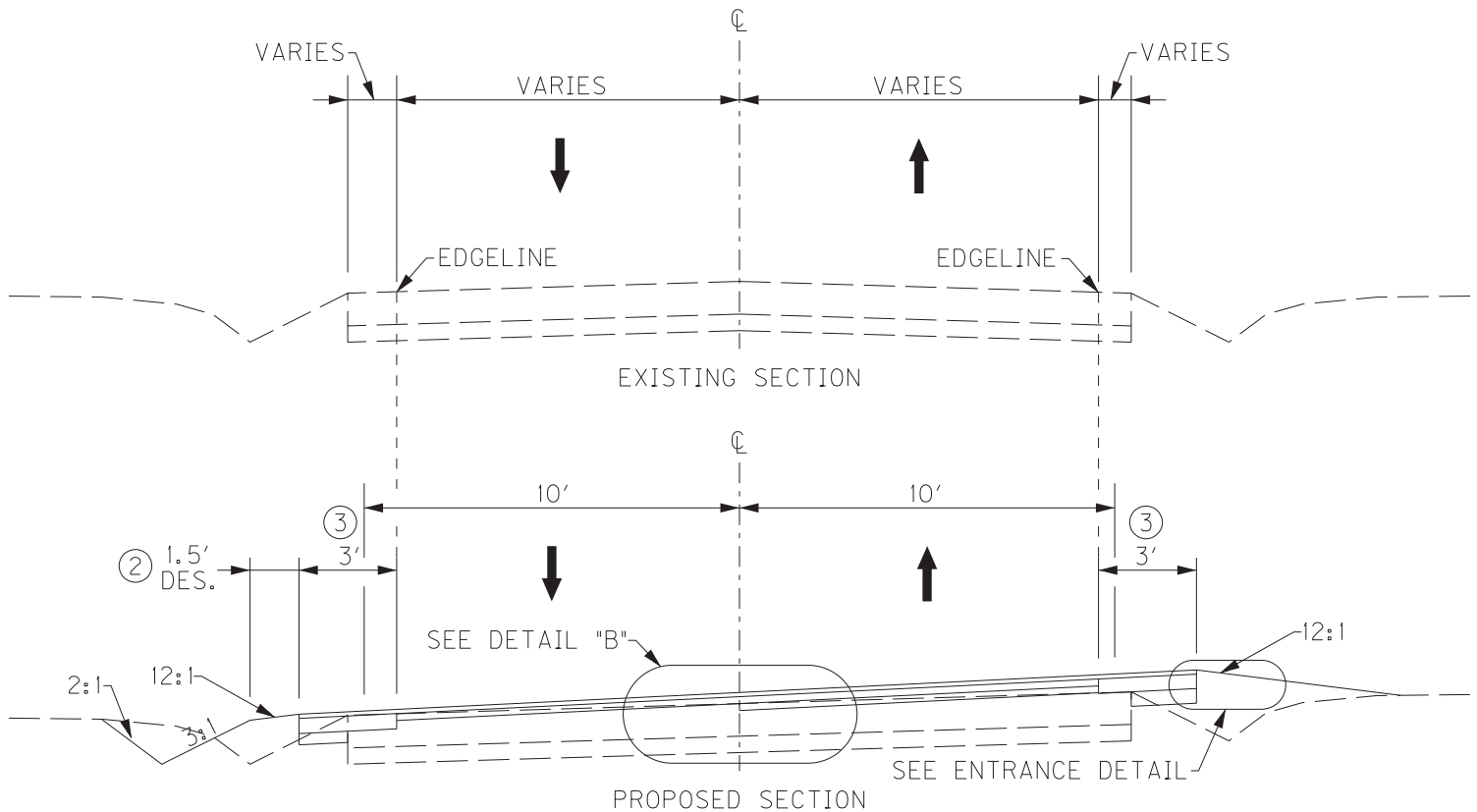

**NOTES:**

- ① SUPERELEVATION IMPROVEMENTS TO ONLY ONE TRAFFIC LANE WILL ONLY INVOLVE A LONGITUDINAL EDGE KEY AT THE CENTERLINE.
- ② IMPROVEMENT TO BOTH LANES WILL INVOLVE AN ADDITIONAL LONGITUDINAL EDGE KEY AT THE EDGELINE OF THE LOW SIDE OF THE CURVE. LONGITUDINAL EDGE KEY IS TO BE PAID AS ASPHALT MILLING & TEXTURING.
- ③ VARY EARTH SHOULDER WIDTH AS DIRECTED BY THE ENGINEER TO AVOID CONFLICTS WITH ROADSIDE FEATURES AND UTILITIES.
- ④ ADJUST SHOULDER GRADE AS DIRECTED BY THE ENGINEER (\*4% MAX.)
- ⑤ LEVELING & WEDGING MIX DESIGN WILL BE BASED ON THE LIFT THICKNESS BEING PLACED FOR EACH CURVE. NUMBER AND THICKNESS OF LIFTS SHOWN IN THESE DETAILS ARE GRAPHICAL REPRESENTATIONS ONLY AND ARE NOT MEANT TO BE TAKEN AS AN INDICATION OF ACTUAL FIELD CONDITIONS.
- ⑥ REFER TO THE RESURFACING SUMMARY FOR LOCATIONS OF EACH MIX.

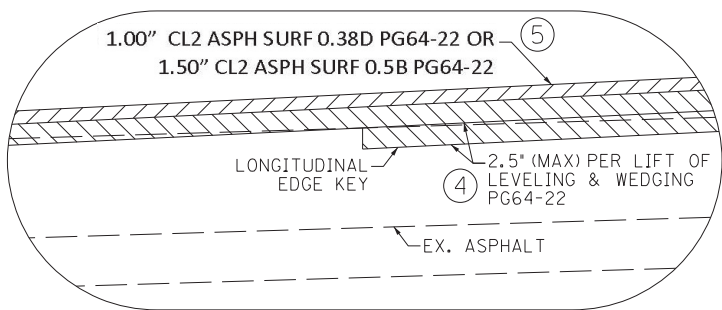

DETAIL "B"

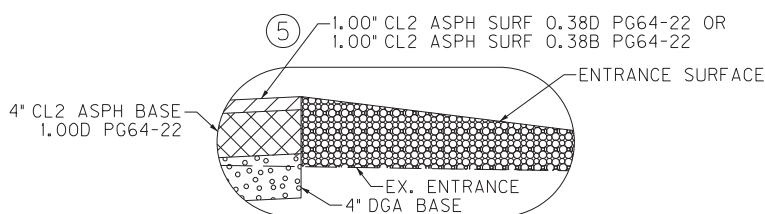

ENTRANCE DETAIL

KY 130  
 SUPERELEVATION IMPROVEMENT  
 DETAIL

COUNTY OF	ITEM NO.
UNION	2-9009.00

# RESURFACING DETAIL

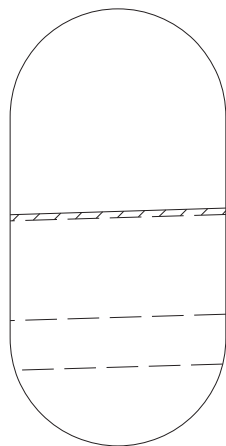
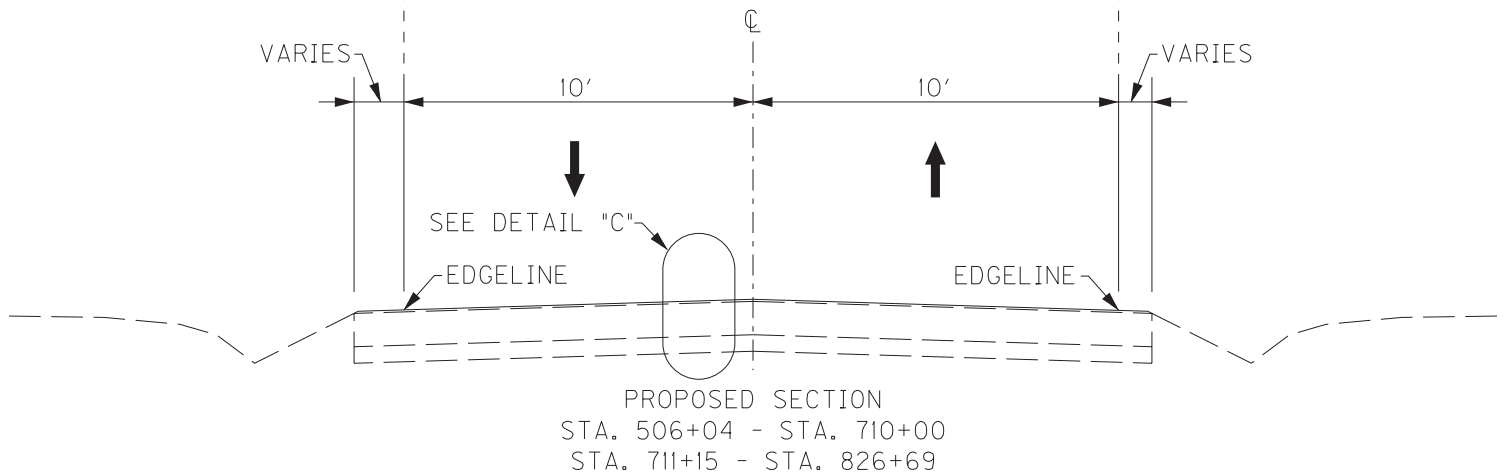
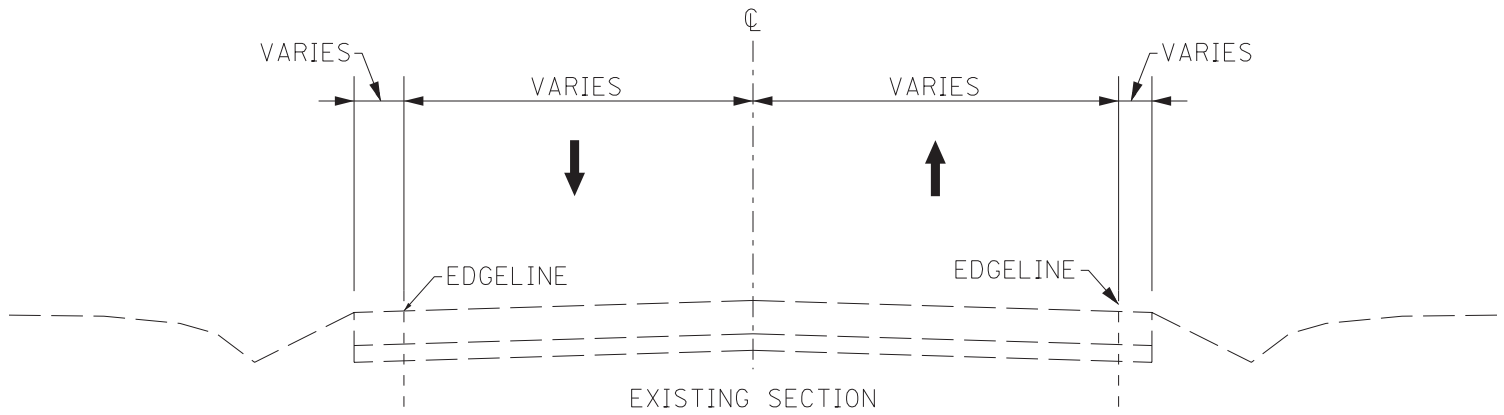

DETAIL "C"

①

1.00" CL2 ASPH SURF 0.38D PG64-22 OR  
 1.50" CL2 ASPH SURF 0.5B PG64-22

NOTE:

① REFER TO THE RESURFACING SUMMARY FOR LOCATIONS OF EACH MIX.

KY 1300  
 RESURFACING  
 DETAIL

COUNTY OF	ITEM NO.
UNION	2-9009.00

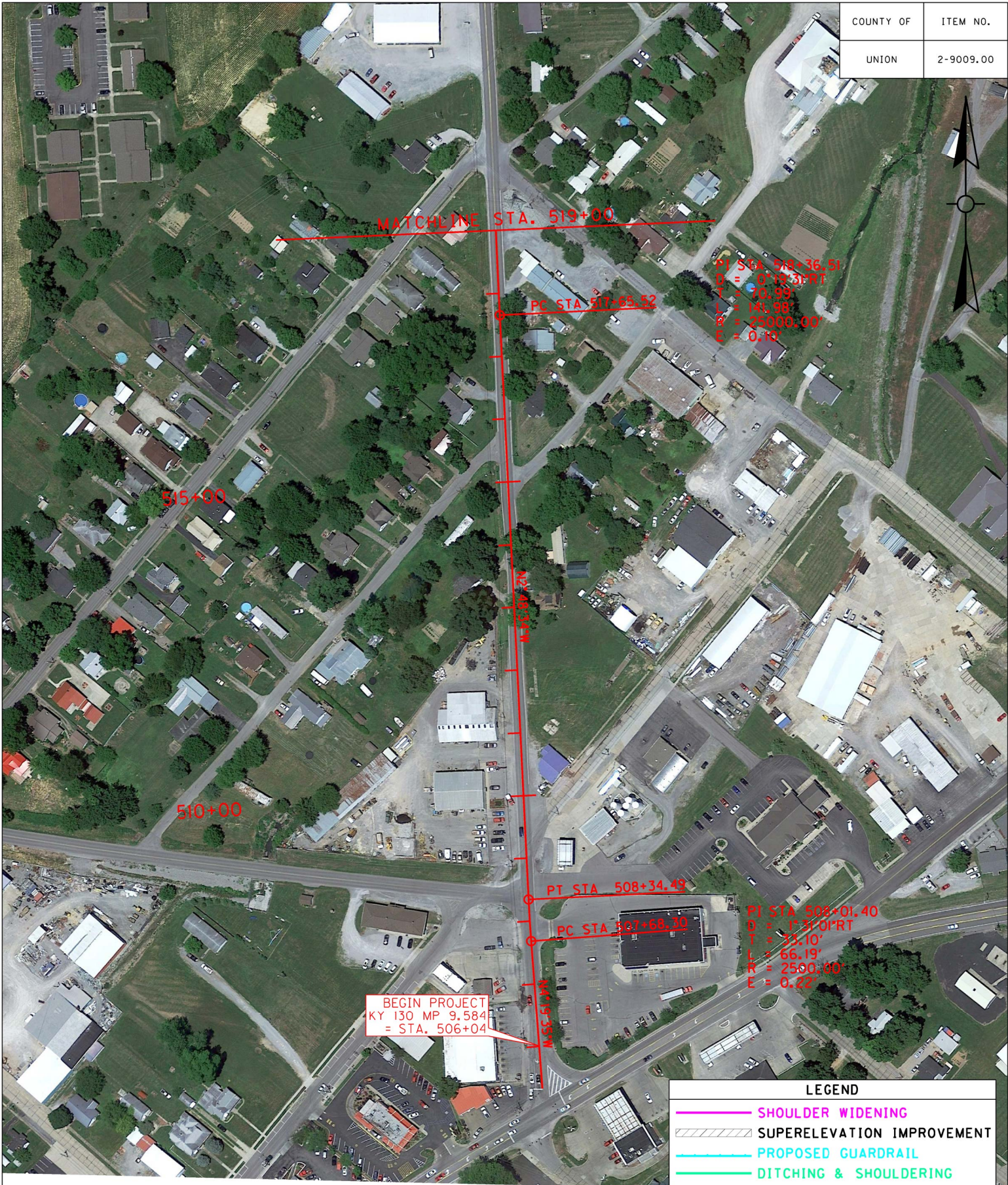

BEGIN PROJECT  
KY 130 MP 9.584  
= STA. 506+04

PT STA 517+36.51  
D = 0°13'31"RT  
T = 30.99'  
L = 141.98'  
R = 25000.00'  
E = 0.10'

PT STA 508+34.49  
D = 1°31'01"RT  
T = 33.10'  
L = 66.19'  
R = 2500.00'  
E = 0.22'

LEGEND	
	SHOULDER WIDENING
	SUPERELEVATION IMPROVEMENT
	PROPOSED GUARDRAIL
	DITCHING & SHOULDERING
	BASE FAILURE REPAIR

SCALE: 1"=200'

KY 130  
PLAN SHEET - 00  
STA. 506+04 TO STA. 519+00

COUNTY OF	ITEM NO.
UNION	2-9009.00

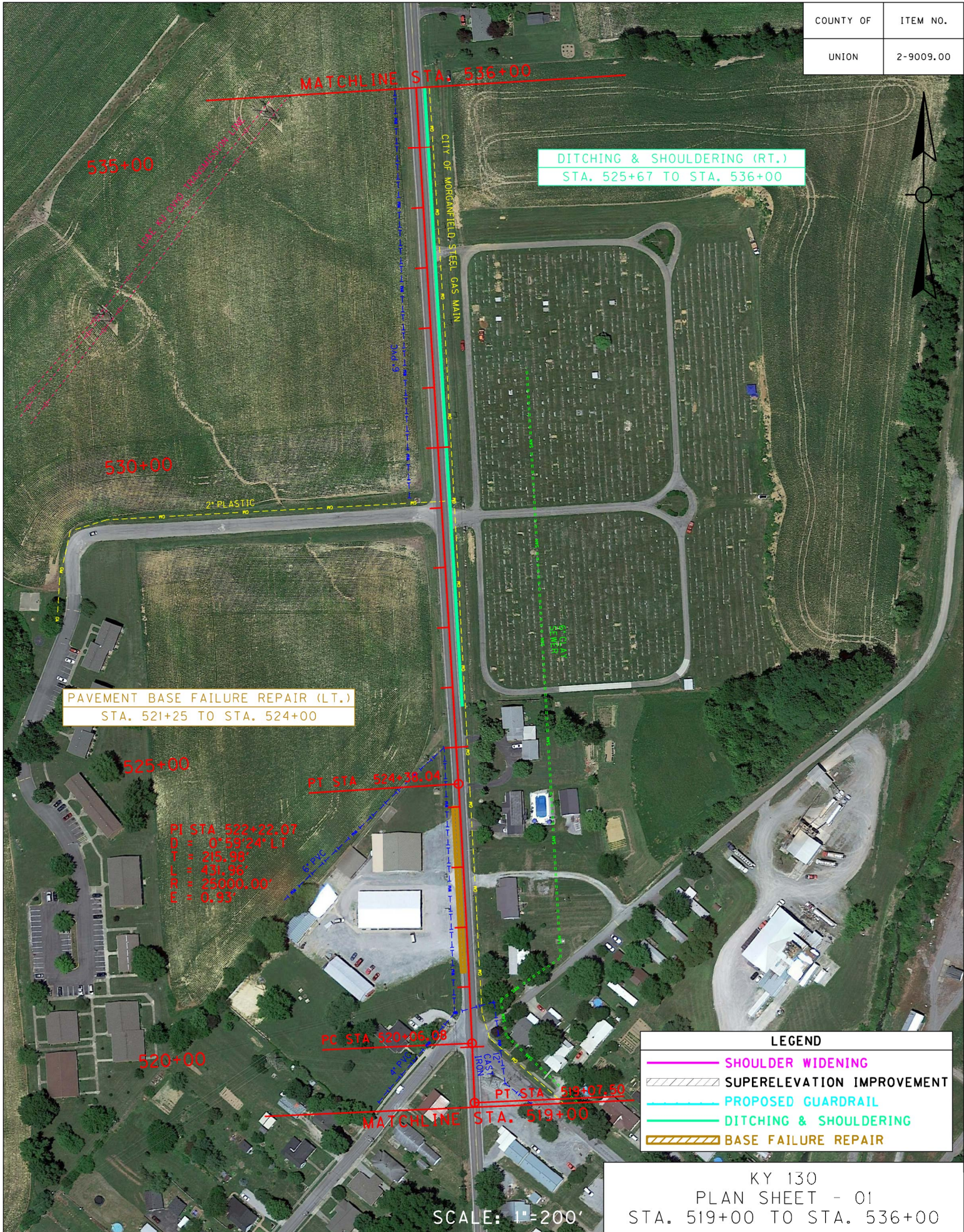

DITCHING & SHOULDERING (RT.)  
STA. 525+67 TO STA. 536+00

PAVEMENT BASE FAILURE REPAIR (LT.)  
STA. 521+25 TO STA. 524+00

PI STA 522+22.07  
D = 0759.24' LT  
L = 205.38'  
R = 431.96'  
M = 25063.00'  
E = 0.93

LEGEND	
	SHOULDER WIDENING
	SUPERELEVATION IMPROVEMENT
	PROPOSED GUARDRAIL
	DITCHING & SHOULDERING
	BASE FAILURE REPAIR

KY 130  
PLAN SHEET - 01  
STA. 519+00 TO STA. 536+00

SCALE: 1"=200'

COUNTY OF	ITEM NO.
UNION	2-9009.00

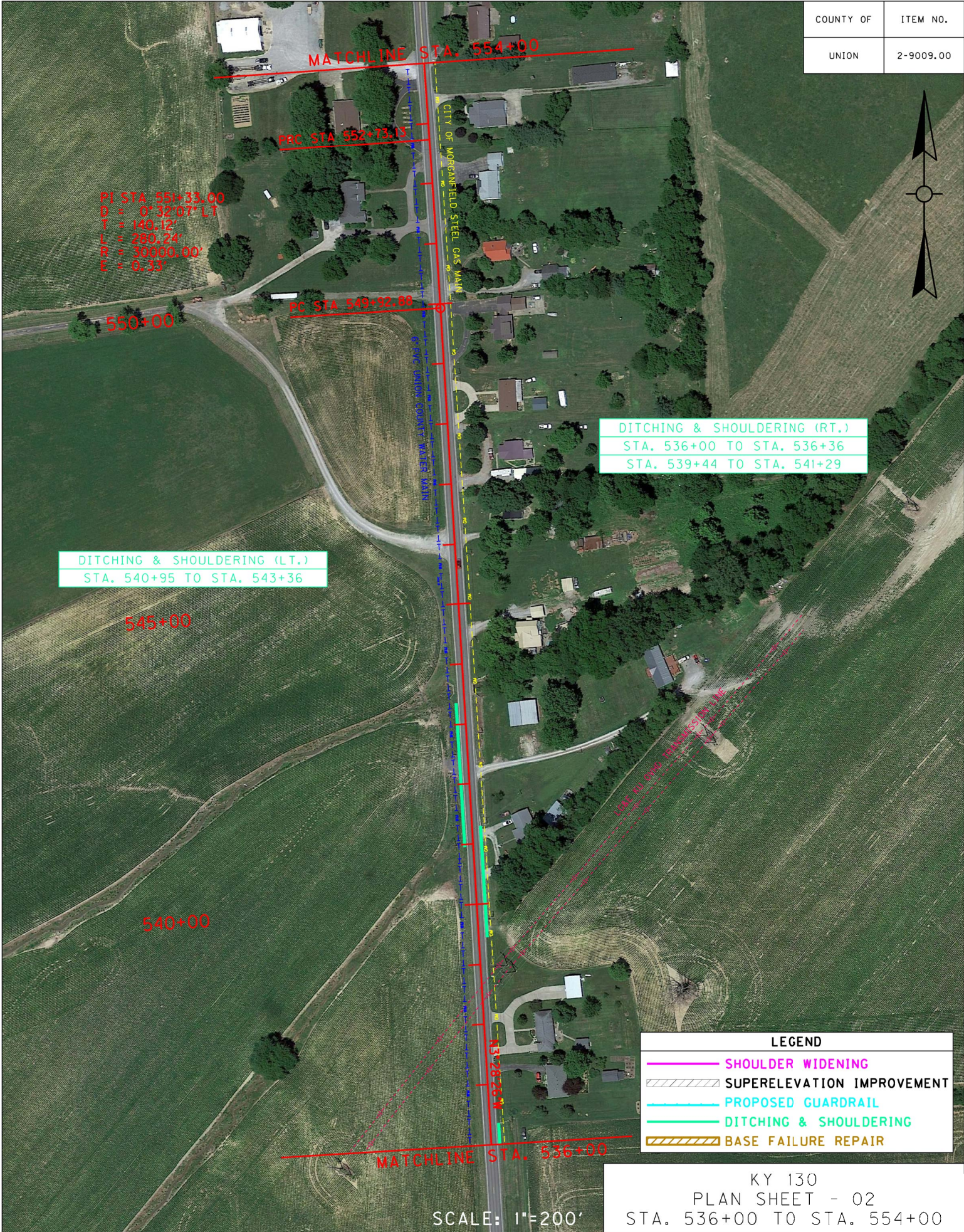

PI STA 55+33.00  
D = 0°32'07" L1  
L = 140.12  
E = 280.24  
R = 30000.00'  
E = 0.33'

DITCHING & SHOULDERING (LT.)  
STA. 540+95 TO STA. 543+36

DITCHING & SHOULDERING (RT.)  
STA. 536+00 TO STA. 536+36  
STA. 539+44 TO STA. 541+29

LEGEND	
	SHOULDER WIDENING
	SUPERELEVATION IMPROVEMENT
	PROPOSED GUARDRAIL
	DITCHING & SHOULDERING
	BASE FAILURE REPAIR

130-26-02-01  
KY 130  
PLAN SHEET - 02  
STA. 536+00 TO STA. 554+00

SCALE: 1"=200'

COUNTY OF	ITEM NO.
UNION	2-9009.00

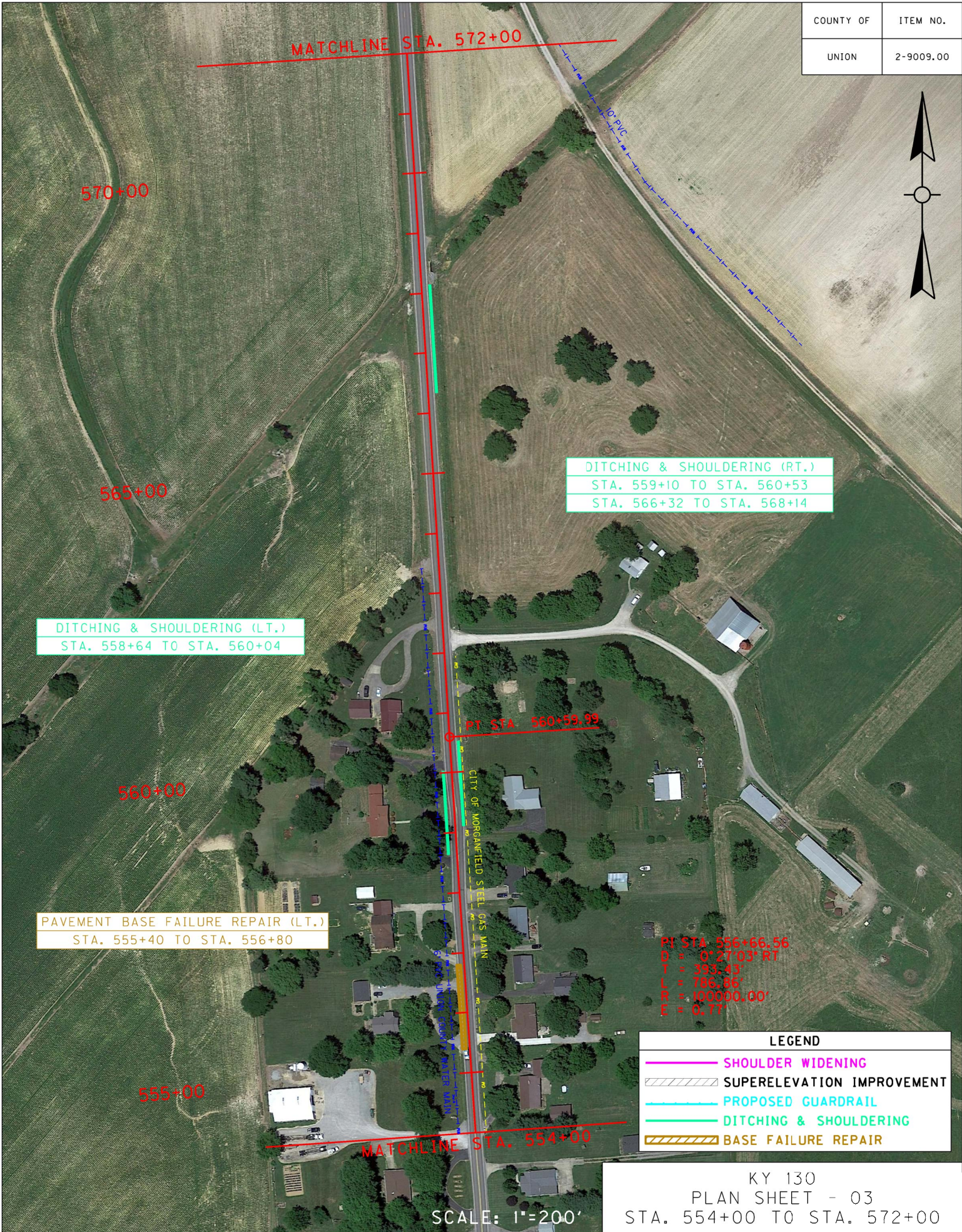

DITCHING & SHOULDERING (LT.)  
STA. 558+64 TO STA. 560+04

DITCHING & SHOULDERING (RT.)  
STA. 559+10 TO STA. 560+53  
STA. 566+32 TO STA. 568+14

PAVEMENT BASE FAILURE REPAIR (LT.)  
STA. 555+40 TO STA. 556+80

PT STA. 556+66.56  
D = 0° 21' 03" RT  
L = 333.43'  
T = 186.86'  
R = 100000.00'  
E = 0.77'

LEGEND	
	SHOULDER WIDENING
	SUPERELEVATION IMPROVEMENT
	PROPOSED GUARDRAIL
	DITCHING & SHOULDERING
	BASE FAILURE REPAIR

KY 130  
PLAN SHEET - 03  
STA. 554+00 TO STA. 572+00

SCALE: 1"=200'

COUNTY OF	ITEM NO.
UNION	2-9009.00

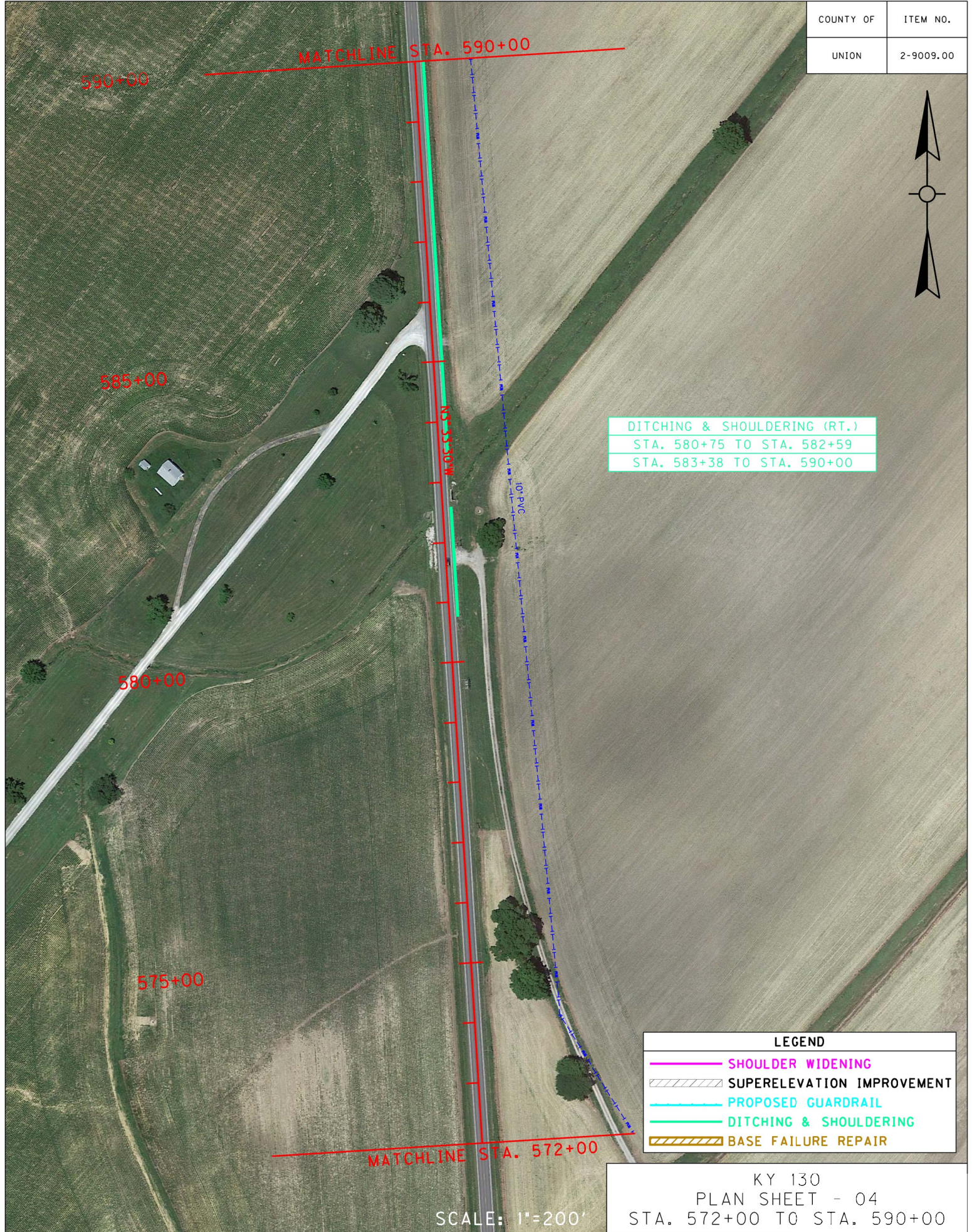

DITCHING & SHOULDERING (RT.)  
STA. 580+75 TO STA. 582+59  
STA. 583+38 TO STA. 590+00

LEGEND	
	SHOULDER WIDENING
	SUPERELEVATION IMPROVEMENT
	PROPOSED GUARDRAIL
	DITCHING & SHOULDERING
	BASE FAILURE REPAIR

KY 130  
PLAN SHEET - 04  
STA. 572+00 TO STA. 590+00

SCALE: 1"=200'

COUNTY OF	ITEM NO.
UNION	2-9009.00

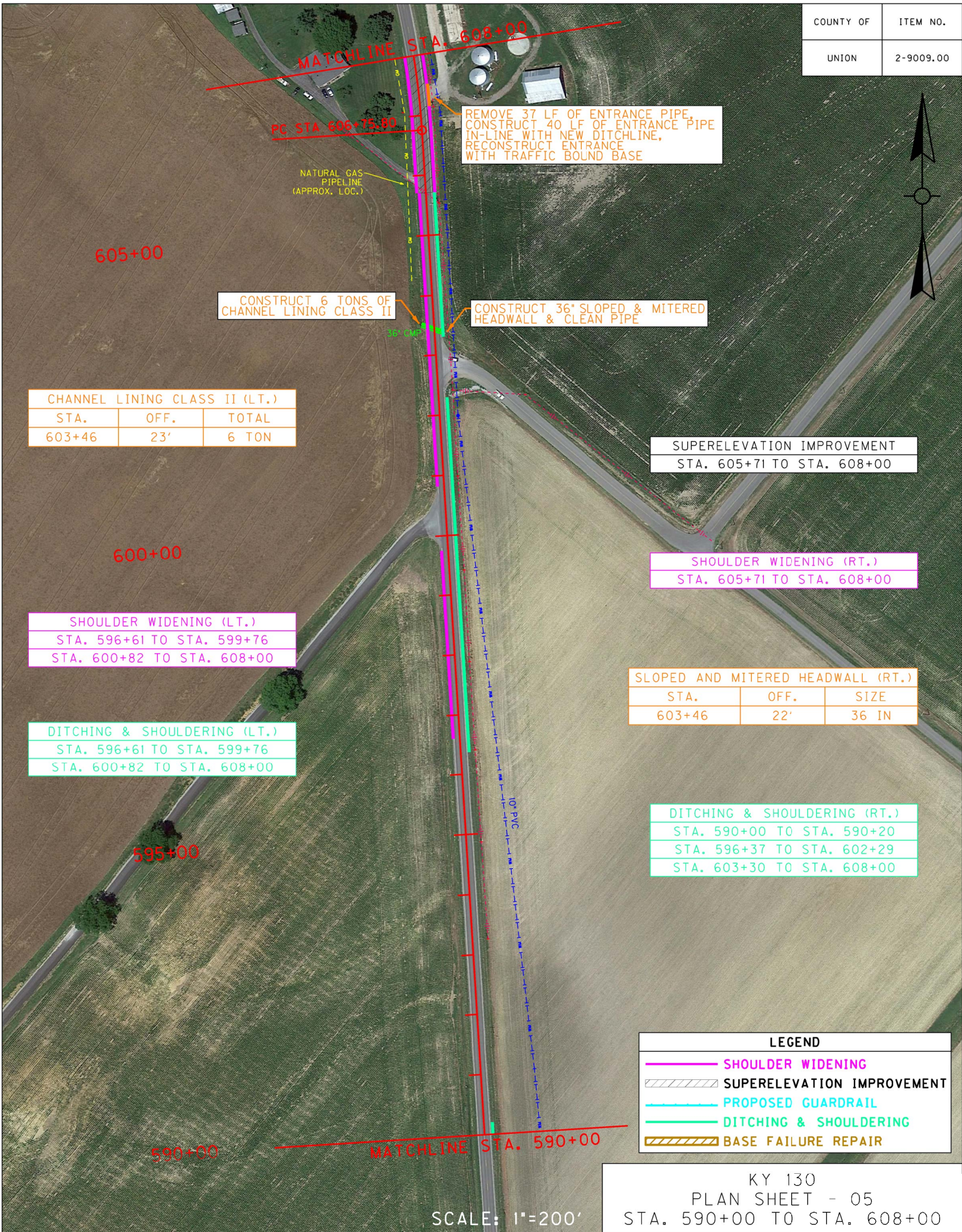

CHANNEL LINING CLASS II (LT.)		
STA.	OFF.	TOTAL
603+46	23'	6 TON

SUPERELEVATION IMPROVEMENT
STA. 605+71 TO STA. 608+00

SHOULDER WIDENING (RT.)
STA. 605+71 TO STA. 608+00

SHOULDER WIDENING (LT.)
STA. 596+61 TO STA. 599+76
STA. 600+82 TO STA. 608+00

SLOPED AND MITERED HEADWALL (RT.)		
STA.	OFF.	SIZE
603+46	22'	36 IN

DITCHING & SHOULDERING (LT.)
STA. 596+61 TO STA. 599+76
STA. 600+82 TO STA. 608+00

DITCHING & SHOULDERING (RT.)
STA. 590+00 TO STA. 590+20
STA. 596+37 TO STA. 602+29
STA. 603+30 TO STA. 608+00

LEGEND	
	SHOULDER WIDENING
	SUPERELEVATION IMPROVEMENT
	PROPOSED GUARDRAIL
	DITCHING & SHOULDERING
	BASE FAILURE REPAIR

KY 130  
PLAN SHEET - 05  
STA. 590+00 TO STA. 608+00

SCALE: 1"=200'

COUNTY OF	ITEM NO.
UNION	2-9009.00

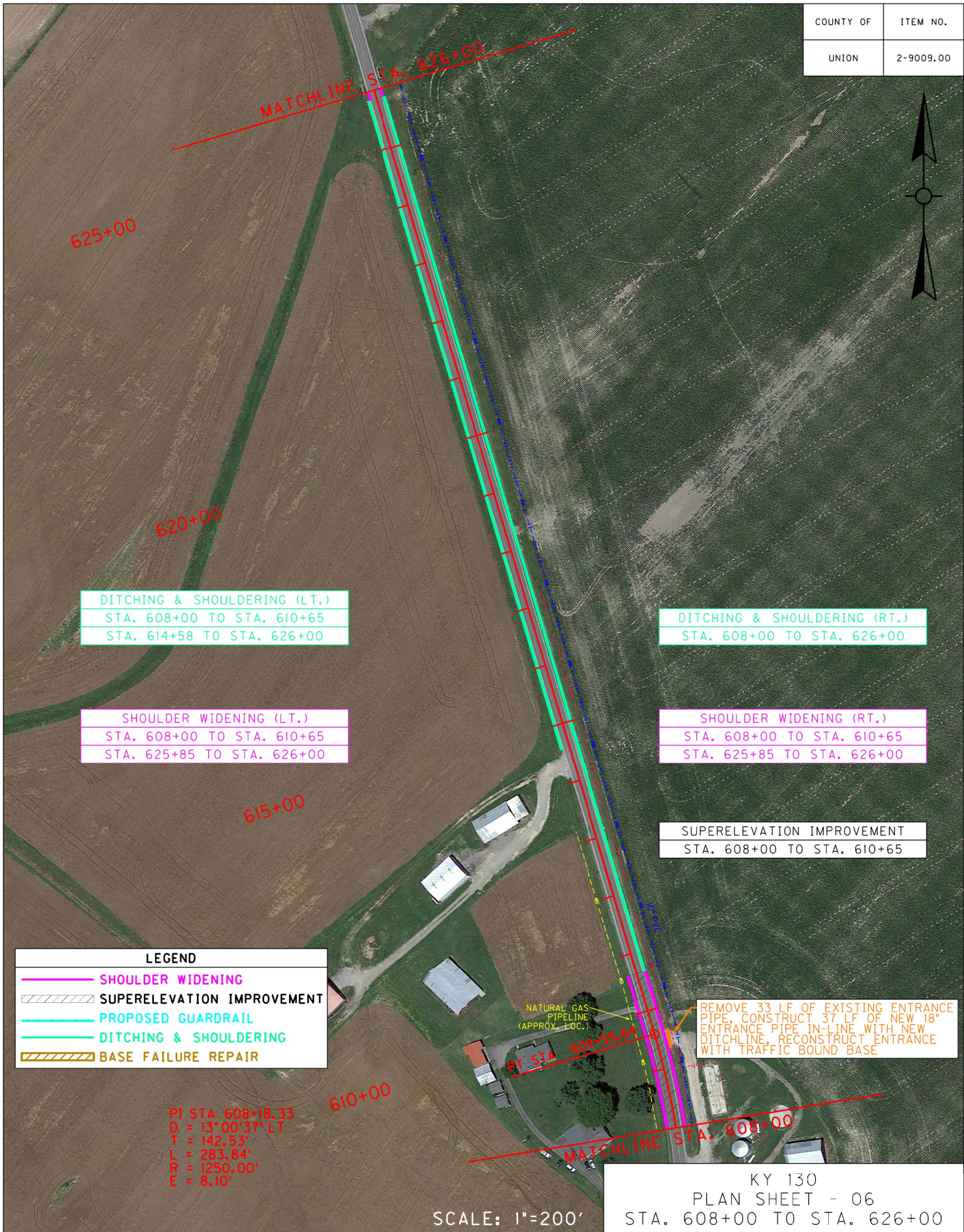

DITCHING & SHOULDERING (LT.)  
STA. 608+00 TO STA. 610+65  
STA. 614+58 TO STA. 626+00

DITCHING & SHOULDERING (RT.)  
STA. 608+00 TO STA. 626+00

SHOULDER WIDENING (LT.)  
STA. 608+00 TO STA. 610+65  
STA. 625+85 TO STA. 626+00

SHOULDER WIDENING (RT.)  
STA. 608+00 TO STA. 610+65  
STA. 625+85 TO STA. 626+00

SUPERELEVATION IMPROVEMENT  
STA. 608+00 TO STA. 610+65

LEGEND	
	SHOULDER WIDENING
	SUPERELEVATION IMPROVEMENT
	PROPOSED GUARDRAIL
	DITCHING & SHOULDERING
	BASE FAILURE REPAIR

PI STA 608+18.33  
D = 13° 00' 37" LT  
T = 142.53'  
L = 283.84'  
R = 1250.00'  
E = 8.10'

NATURAL GAS PIPELINE (APPROX. LOC.)

REMOVE 33 LF OF EXISTING ENTRANCE PIPE, CONSTRUCT 37 LF OF NEW 18" ENTRANCE PIPE IN-LINE WITH NEW DITCHLINE, RECONSTRUCT ENTRANCE WITH TRAFFIC BOUND BASE

SCALE: 1"=200'

KY 130  
PLAN SHEET - 06  
STA. 608+00 TO STA. 626+00

COUNTY OF	ITEM NO.
UNION	2-9009.00



SHOULDER WIDENING (LT.)  
STA. 626+00 TO STA. 644+00

SHOULDER WIDENING (RT.)  
STA. 626+00 TO STA. 644+00

DITCHING & SHOULDERING (LT.)  
STA. 626+00 TO STA. 644+00

DITCHING & SHOULDERING (RT.)  
STA. 626+00 TO STA. 644+00

LEGEND	
	SHOULDER WIDENING
	SUPERELEVATION IMPROVEMENT
	PROPOSED GUARDRAIL
	DITCHING & SHOULDERING
	BASE FAILURE REPAIR

KY 130  
PLAN SHEET - 07  
STA. 626+00 TO STA. 644+00

SCALE: 1"=200'

COUNTY OF	ITEM NO.
UNION	2-9009.00

STEEL W-BEAM GUARDRAIL (RT.)						
BEGIN STA.	TERM. SEC.	END TRMNT.	END STA.	TERM. SEC.	END TRMNT.	LENGTH
658+34	--	TY 1	658+84	--	--	--

REMOVE GUARDRAIL (RT.)						
BEGIN STA.	TERM. SEC.	END TRMNT.	END STA.	TERM. SEC.	END TRMNT.	LENGTH
658+34	--	TY 7	658+84	--	--	--



MATCHLINE STA. 652+00

660+00

655+00

650+00

645+00

DITCHING & SHOULDERING (LT.)  
STA. 644+00 TO STA. 659+67

DITCHING & SHOULDERING (RT.)  
STA. 644+00 TO STA. 658+36

SHOULDER WIDENING (LT.)  
STA. 644+00 TO STA. 659+67

SHOULDER WIDENING (RT.)  
STA. 644+00 TO STA. 652+34

LEGEND	
	SHOULDER WIDENING
	SUPERELEVATION IMPROVEMENT
	PROPOSED GUARDRAIL
	DITCHING & SHOULDERING
	BASE FAILURE REPAIR

SCALE: 1"=200'

KY 130  
PLAN SHEET - 08  
STA. 644+00 TO STA. 662+00

COUNTY OF	ITEM NO.
UNION	2-9009.00

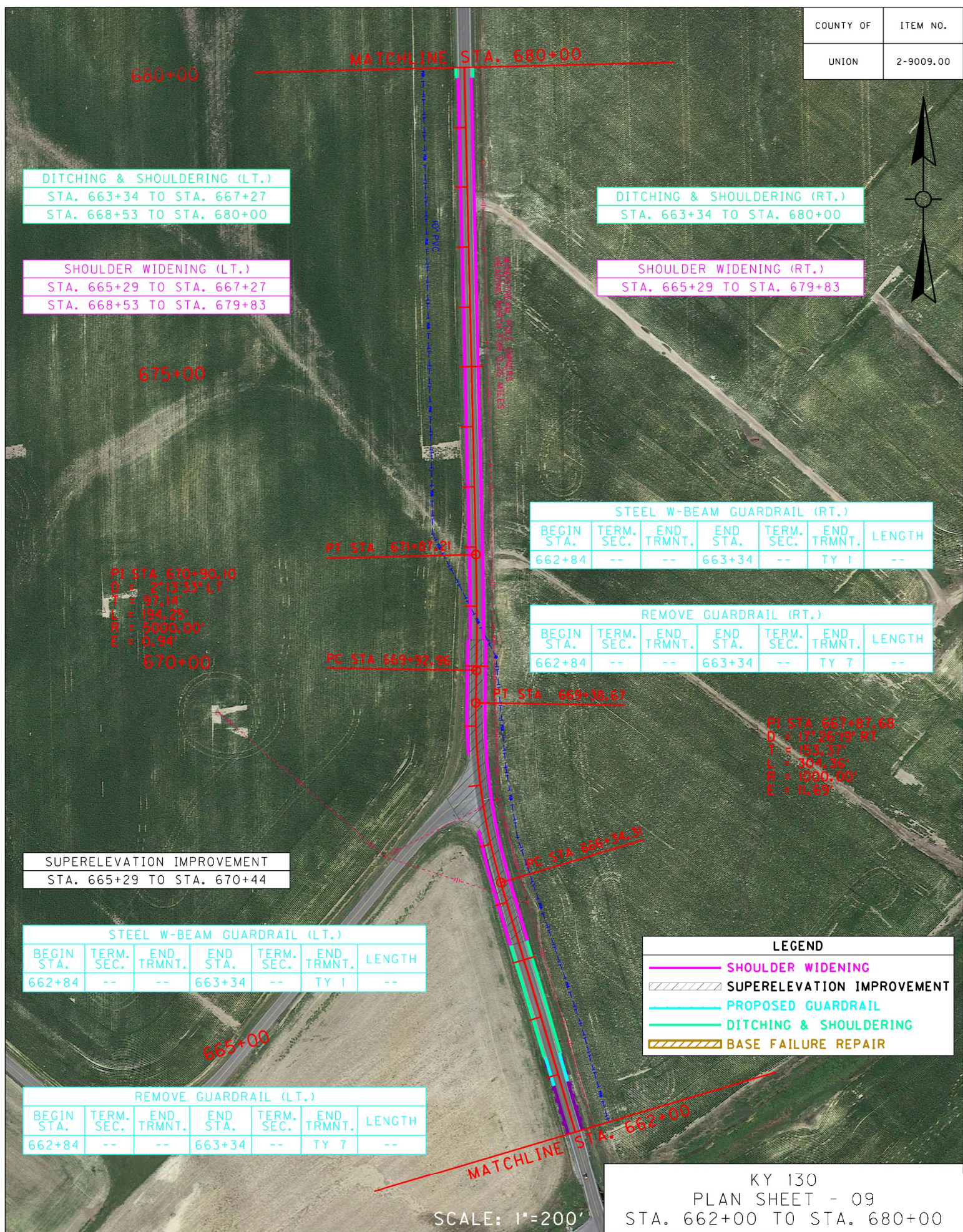

DITCHING & SHOULDERING (LT.)	
STA. 663+34 TO STA. 667+27	
STA. 668+53 TO STA. 680+00	

DITCHING & SHOULDERING (RT.)	
STA. 663+34 TO STA. 680+00	

SHOULDER WIDENING (LT.)	
STA. 665+29 TO STA. 667+27	
STA. 668+53 TO STA. 679+83	

SHOULDER WIDENING (RT.)	
STA. 665+29 TO STA. 679+83	

PT STA 670+90.00  
 D = 27°13'33" LT  
 L = 97.14'  
 R = 194.75'  
 R = 5000.00'  
 E = 0.94'

PT STA 671+87.21

STEEL W-BEAM GUARDRAIL (RT.)						
BEGIN STA.	TERM. SEC.	END TRMNT.	END STA.	TERM. SEC.	END TRMNT.	LENGTH
662+84	--	--	663+34	--	TY 1	--

REMOVE GUARDRAIL (RT.)						
BEGIN STA.	TERM. SEC.	END TRMNT.	END STA.	TERM. SEC.	END TRMNT.	LENGTH
662+84	--	--	663+34	--	TY 7	--

PC STA 669+92.95

PT STA 669+38.67

PT STA 661+87.68  
 D = 17°26'19" RT  
 L = 153.37'  
 R = 304.35'  
 R = 1000.00'  
 E = 0.69'

SUPERELEVATION IMPROVEMENT	
STA. 665+29 TO STA. 670+44	

STEEL W-BEAM GUARDRAIL (LT.)						
BEGIN STA.	TERM. SEC.	END TRMNT.	END STA.	TERM. SEC.	END TRMNT.	LENGTH
662+84	--	--	663+34	--	TY 1	--

REMOVE GUARDRAIL (LT.)						
BEGIN STA.	TERM. SEC.	END TRMNT.	END STA.	TERM. SEC.	END TRMNT.	LENGTH
662+84	--	--	663+34	--	TY 7	--

LEGEND	
	SHOULDER WIDENING
	SUPERELEVATION IMPROVEMENT
	PROPOSED GUARDRAIL
	DITCHING & SHOULDERING
	BASE FAILURE REPAIR

SCALE: 1"=200'  
 KY 130  
 PLAN SHEET - 09  
 STA. 662+00 TO STA. 680+00

COUNTY OF	ITEM NO.
UNION	2-9009.00



PI STA. 697+31.08  
 D = 27°21'06" LT  
 T = 102.63'  
 L = 205.23'  
 R = 5000.00'  
 E = 1.05'

PC STA. 696+38.45

PAVEMENT BASE FAILURE REPAIR (LT.)  
 STA. 697+50 TO STA. 698+00

DITCHING & SHOULDERING (LT.)  
 STA. 680+00 TO STA. 697+05

DITCHING & SHOULDERING (RT.)  
 STA. 680+00 TO STA. 697+84

LEGEND	
	SHOULDER WIDENING
	SUPERELEVATION IMPROVEMENT
	PROPOSED GUARDRAIL
	DITCHING & SHOULDERING
	BASE FAILURE REPAIR

KY 130  
 PLAN SHEET - 10  
 STA. 680+00 TO STA. 698+00

SCALE: 1"=200'

COUNTY OF	ITEM NO.
UNION	2-9009.00

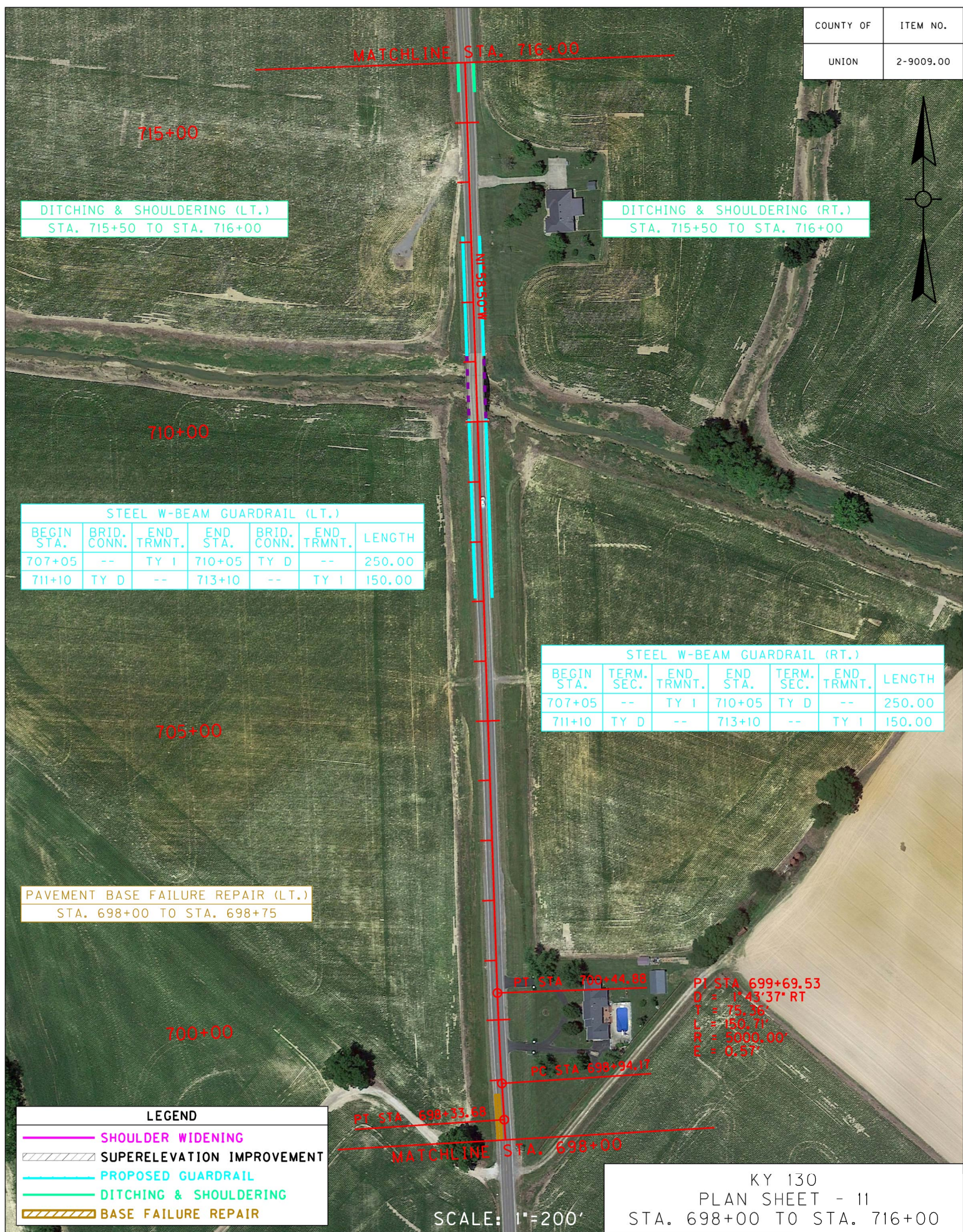

DITCHING & SHOULDERING (LT.)  
STA. 715+50 TO STA. 716+00

DITCHING & SHOULDERING (RT.)  
STA. 715+50 TO STA. 716+00

STEEL W-BEAM GUARDRAIL (LT.)						
BEGIN STA.	BRID. CONN.	END TRMNT.	END STA.	BRID. CONN.	END TRMNT.	LENGTH
707+05	--	TY 1	710+05	TY D	--	250.00
711+10	TY D	--	713+10	--	TY 1	150.00

STEEL W-BEAM GUARDRAIL (RT.)						
BEGIN STA.	TERM. SEC.	END TRMNT.	END STA.	TERM. SEC.	END TRMNT.	LENGTH
707+05	--	TY 1	710+05	TY D	--	250.00
711+10	TY D	--	713+10	--	TY 1	150.00

PAVEMENT BASE FAILURE REPAIR (LT.)  
STA. 698+00 TO STA. 698+75

PI STA 700+44.88  
PC STA 698+94.17  
PI STA 699+69.53  
D = 1'43'37" RT  
T = 75.36'  
L = 150.71'  
R = 5000.00'  
E = 0.87'

LEGEND	
	SHOULDER WIDENING
	SUPERELEVATION IMPROVEMENT
	PROPOSED GUARDRAIL
	DITCHING & SHOULDERING
	BASE FAILURE REPAIR

SCALE: 1"=200'  
KY 130  
PLAN SHEET - 11  
STA. 698+00 TO STA. 716+00

COUNTY OF	ITEM NO.
UNION	2-9009.00

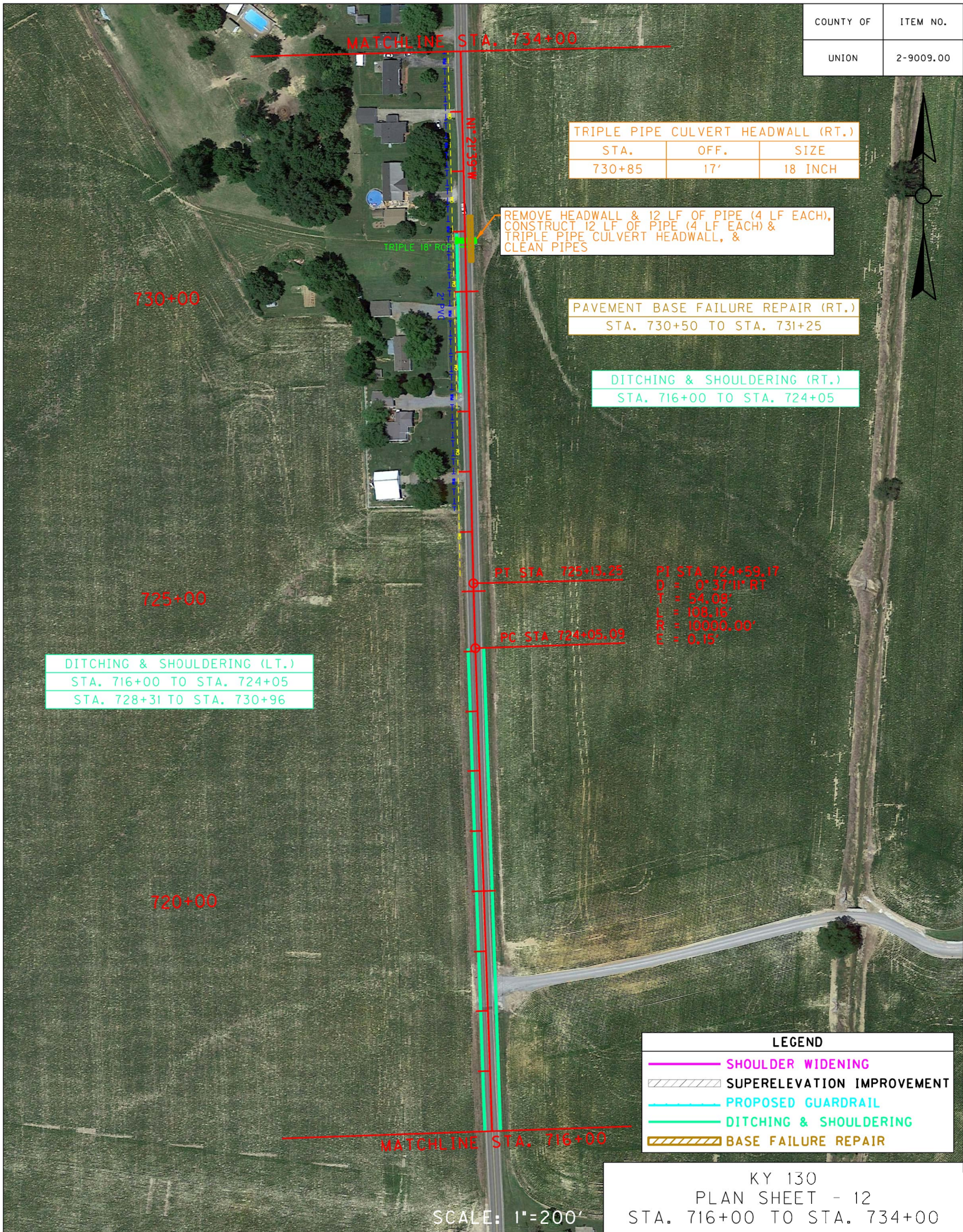

TRIPLE PIPE CULVERT HEADWALL (RT.)		
STA.	OFF.	SIZE
730+85	17'	18 INCH

REMOVE HEADWALL & 12 LF OF PIPE (4 LF EACH),  
CONSTRUCT 12 LF OF PIPE (4 LF EACH) &  
TRIPLE PIPE CULVERT HEADWALL, &  
CLEAN PIPES

PAVEMENT BASE FAILURE REPAIR (RT.)  
STA. 730+50 TO STA. 731+25

DITCHING & SHOULDERING (RT.)  
STA. 716+00 TO STA. 724+05

DITCHING & SHOULDERING (LT.)  
STA. 716+00 TO STA. 724+05  
STA. 728+31 TO STA. 730+96

PI STA 724+59.17  
D = 6° 57' 11" RT  
T = 54.08'  
L = 108.16'  
R = 10000.00'  
E = 0.15'

PT STA 725+13.25  
PC STA 724+05.09

LEGEND	
	SHOULDER WIDENING
	SUPERELEVATION IMPROVEMENT
	PROPOSED GUARDRAIL
	DITCHING & SHOULDERING
	BASE FAILURE REPAIR

SCALE: 1"=200'  
KY 130  
PLAN SHEET - 12  
STA. 716+00 TO STA. 734+00

COUNTY OF	ITEM NO.
UNION	2-9009.00

SUPERELEVATION IMPROVEMENT  
STA. 750+04 TO STA. 752+00

STANDARD CONCRETE HEADWALL (LT.)		
STA.	OFF.	SIZE
749+20	17'	24 INCH

REMOVE 4 LF OF PIPE,  
CONSTRUCT 4 LF OF PIPE &  
STANDARD CONCRETE HEADWALL  
& CLEAN PIPE

REMOVE 4 LF OF PIPE,  
CONSTRUCT 9 LF OF PIPE,  
SLOPED & MITERED HEADWALL,  
& 36 TON OF  
CHANNEL LINING CLASS II

PI STA 750+35.90  
D = 7'18" RT  
T = 111.18'  
L = 232.06'  
R = 1750.00'  
E = 3.53'

STEEL W-BEAM GUARDRAIL (RT.)						
BEGIN STA.	TERM. SEC.	END TRMNT.	END STA.	TERM. SEC.	END TRMNT.	LENGTH
750+65	--	TY 1	752+00	--	--	85.00

SLOPED AND MITERED HEADWALL (RT.)		
STA.	OFF.	SIZE
749+20	22'	24 INCH

CHANNEL LINING CLASS II (RT.)		
STA.	OFF.	TOTAL
749+16 TO 749+31	20' TO 25'	36 TON

SHOULDER WIDENING (RT.)  
STA. 745+37 TO STA. 752+00

DITCHING & SHOULDERING (RT.)  
STA. 745+37 TO STA. 752+00

SHOULDER WIDENING (LT.)  
STA. 742+15 TO STA. 752+00

DITCHING & SHOULDERING (LT.)  
STA. 734+42 TO STA. 741+35  
STA. 742+15 TO STA. 752+00

PI STA 742+37.14  
D = 9'59" RT  
T = 215.47'  
L = 349.46'  
R = 3150.00'  
E = 12.02'

LEGEND	
	SHOULDER WIDENING
	SUPERELEVATION IMPROVEMENT
	PROPOSED GUARDRAIL
	DITCHING & SHOULDERING
	BASE FAILURE REPAIR

KY 130  
PLAN SHEET - 13  
STA. 734+00 TO STA. 752+00

SCALE: 1"=200'

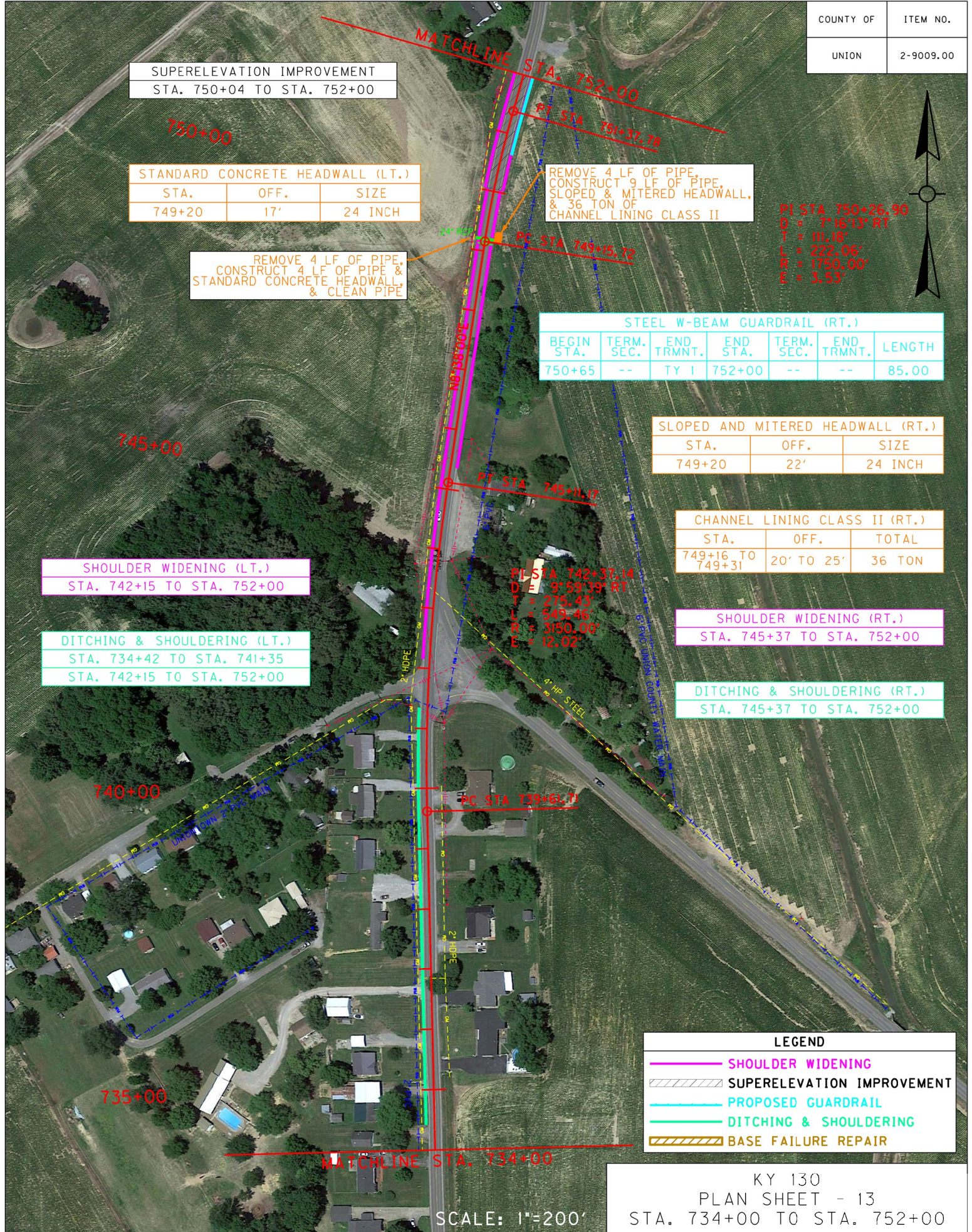

COUNTY OF	ITEM NO.
UNION	2-9009.00

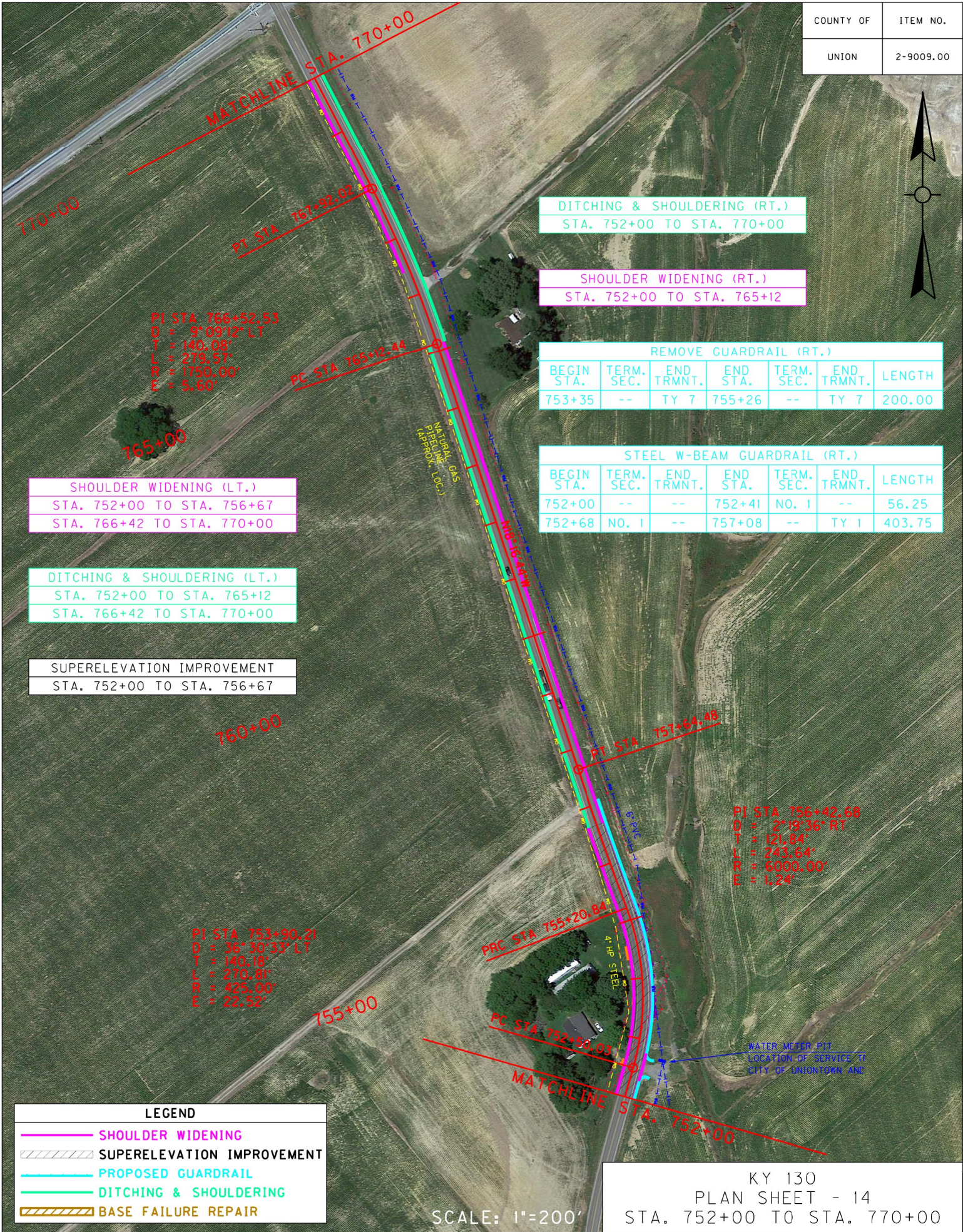

DITCHING & SHOULDERING (RT.)  
STA. 752+00 TO STA. 770+00

SHOULDER WIDENING (RT.)  
STA. 752+00 TO STA. 765+12

REMOVE GUARDRAIL (RT.)						
BEGIN STA.	TERM. SEC.	END TRMNT.	END STA.	TERM. SEC.	END TRMNT.	LENGTH
753+35	--	TY 7	755+26	--	TY 7	200.00

STEEL W-BEAM GUARDRAIL (RT.)						
BEGIN STA.	TERM. SEC.	END TRMNT.	END STA.	TERM. SEC.	END TRMNT.	LENGTH
752+00	--	--	752+41	NO. 1	--	56.25
752+68	NO. 1	--	757+08	--	TY 1	403.75

SHOULDER WIDENING (LT.)  
STA. 752+00 TO STA. 756+67  
STA. 766+42 TO STA. 770+00

DITCHING & SHOULDERING (LT.)  
STA. 752+00 TO STA. 765+12  
STA. 766+42 TO STA. 770+00

SUPERELEVATION IMPROVEMENT  
STA. 752+00 TO STA. 756+67

PI STA 766+52.53  
D = 9°09'12" LT  
T = 140.08'  
L = 279.57'  
R = 1793.00'  
E = 5.60'

PI STA 753+90.21  
D = 36°10'37" LT  
T = 190.18'  
L = 279.81'  
R = 426.00'  
E = 23.52'

PI STA 755+42.68  
D = 2°09'36" RT  
T = 121.84'  
L = 343.64'  
R = 6000.00'  
E = 1.24'

LEGEND	
	SHOULDER WIDENING
	SUPERELEVATION IMPROVEMENT
	PROPOSED GUARDRAIL
	DITCHING & SHOULDERING
	BASE FAILURE REPAIR

SCALE: 1"=200'  
KY 130  
PLAN SHEET - 14  
STA. 752+00 TO STA. 770+00

COUNTY OF	ITEM NO.
UNION	2-9009.00

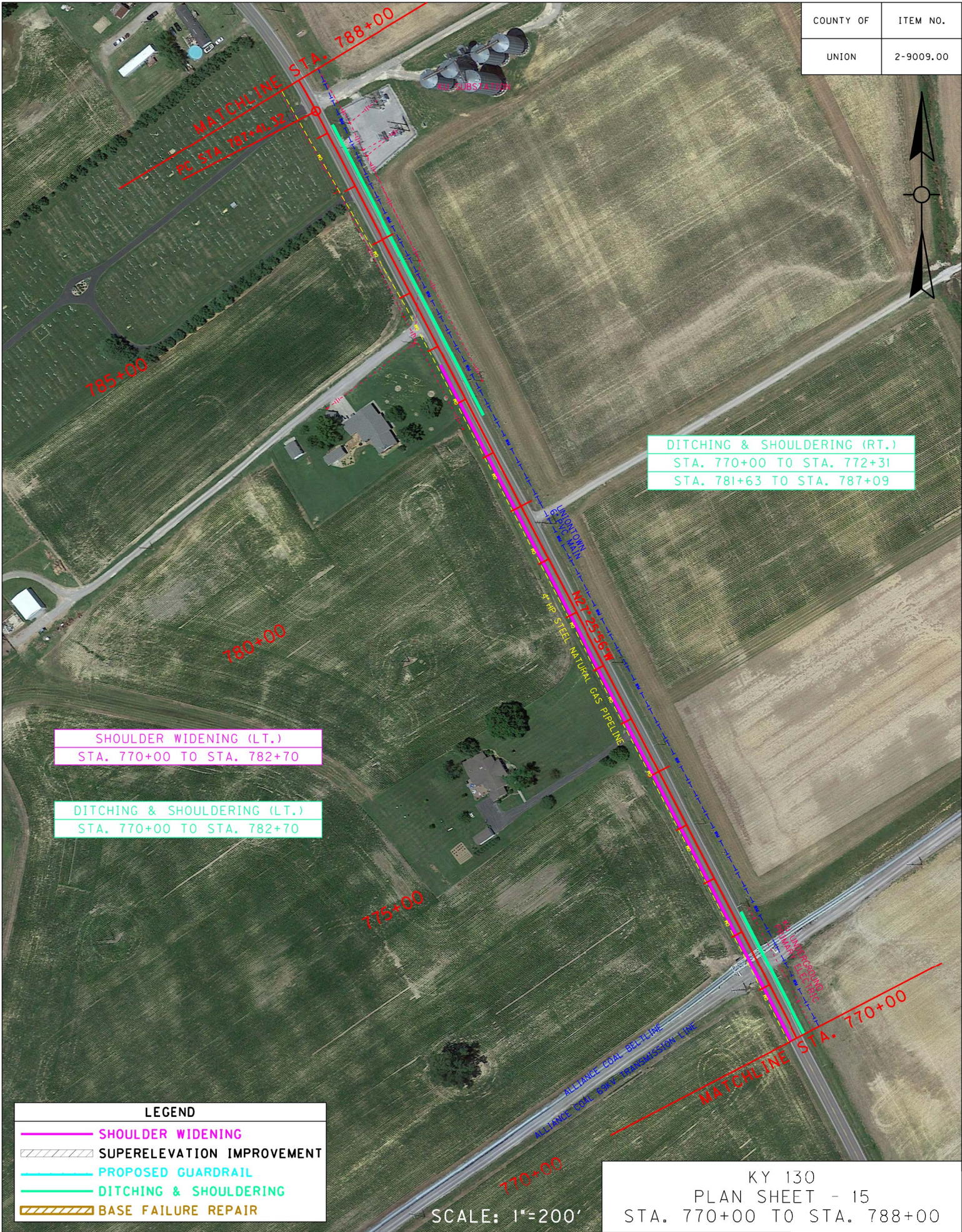

DITCHING & SHOULDERING (RT.)  
STA. 770+00 TO STA. 772+31  
STA. 781+63 TO STA. 787+09

SHOULDER WIDENING (LT.)  
STA. 770+00 TO STA. 782+70

DITCHING & SHOULDERING (LT.)  
STA. 770+00 TO STA. 782+70

LEGEND	
	SHOULDER WIDENING
	SUPERELEVATION IMPROVEMENT
	PROPOSED GUARDRAIL
	DITCHING & SHOULDERING
	BASE FAILURE REPAIR

SCALE: 1"=200'  
KY 130  
PLAN SHEET - 15  
STA. 770+00 TO STA. 788+00

COUNTY OF	ITEM NO.
UNION	2-9009.00



**LEGEND**

- SHOULDER WIDENING
- SUPERELEVATION IMPROVEMENT
- PROPOSED GUARDRAIL
- DITCHING & SHOULDERING
- BASE FAILURE REPAIR

PI STA 798+25.59  
 D = 127.22' LT  
 T = 119.80'  
 L = 235.53'  
 R = 3089.05'  
 C = 0.72

PI STA 799+02.81  
 D = 207.20' 44" LT  
 T = 161.49'  
 L = 319.59'  
 R = 908.00'  
 C = 14.37

SCALE: 1"=200'  
 KY 130  
 PLAN SHEET - 16  
 STA. 788+00 TO STA. 803+00

COUNTY OF	ITEM NO.
UNION	2-9009.00

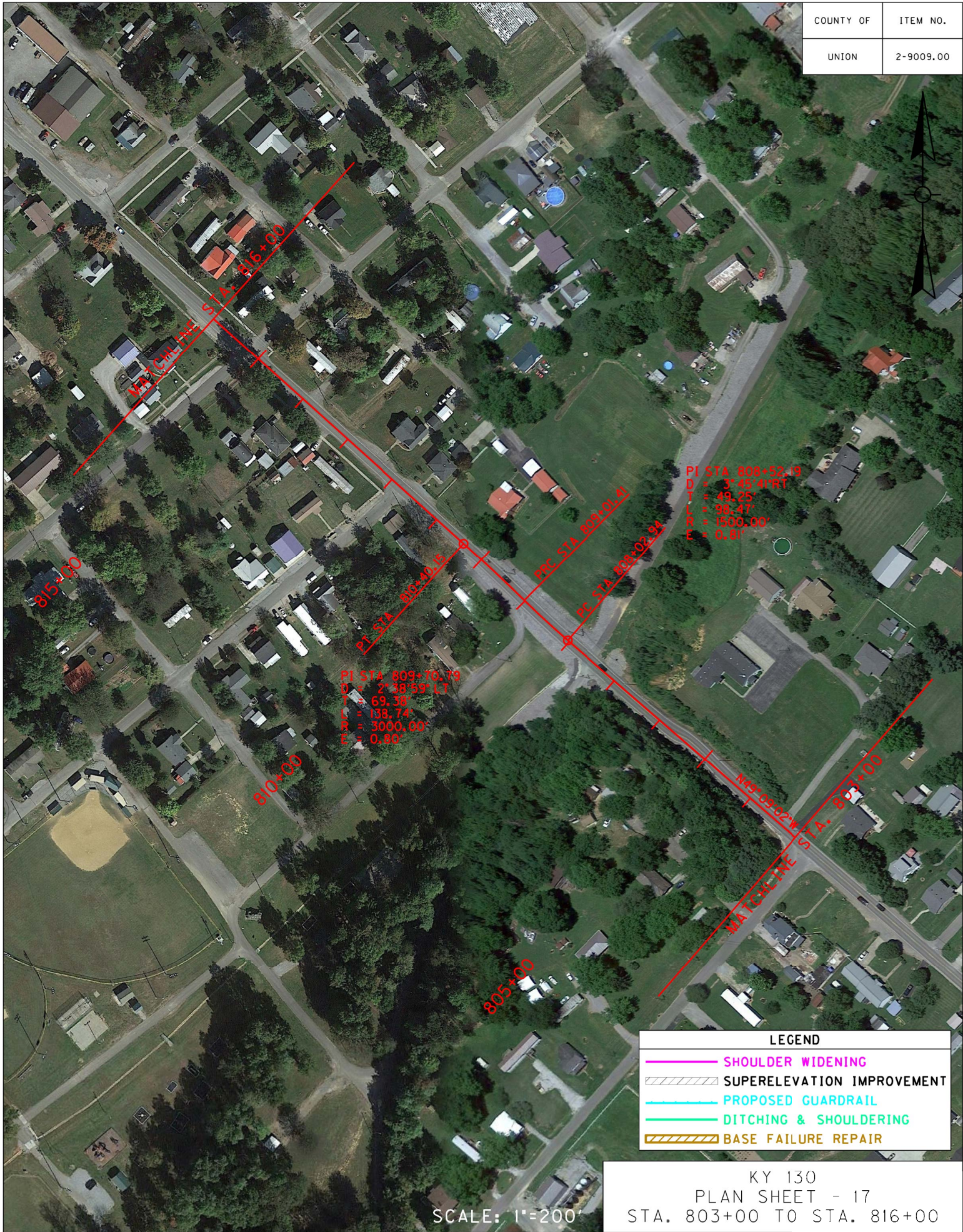

COUNTY OF	ITEM NO.
UNION	2-9009.00

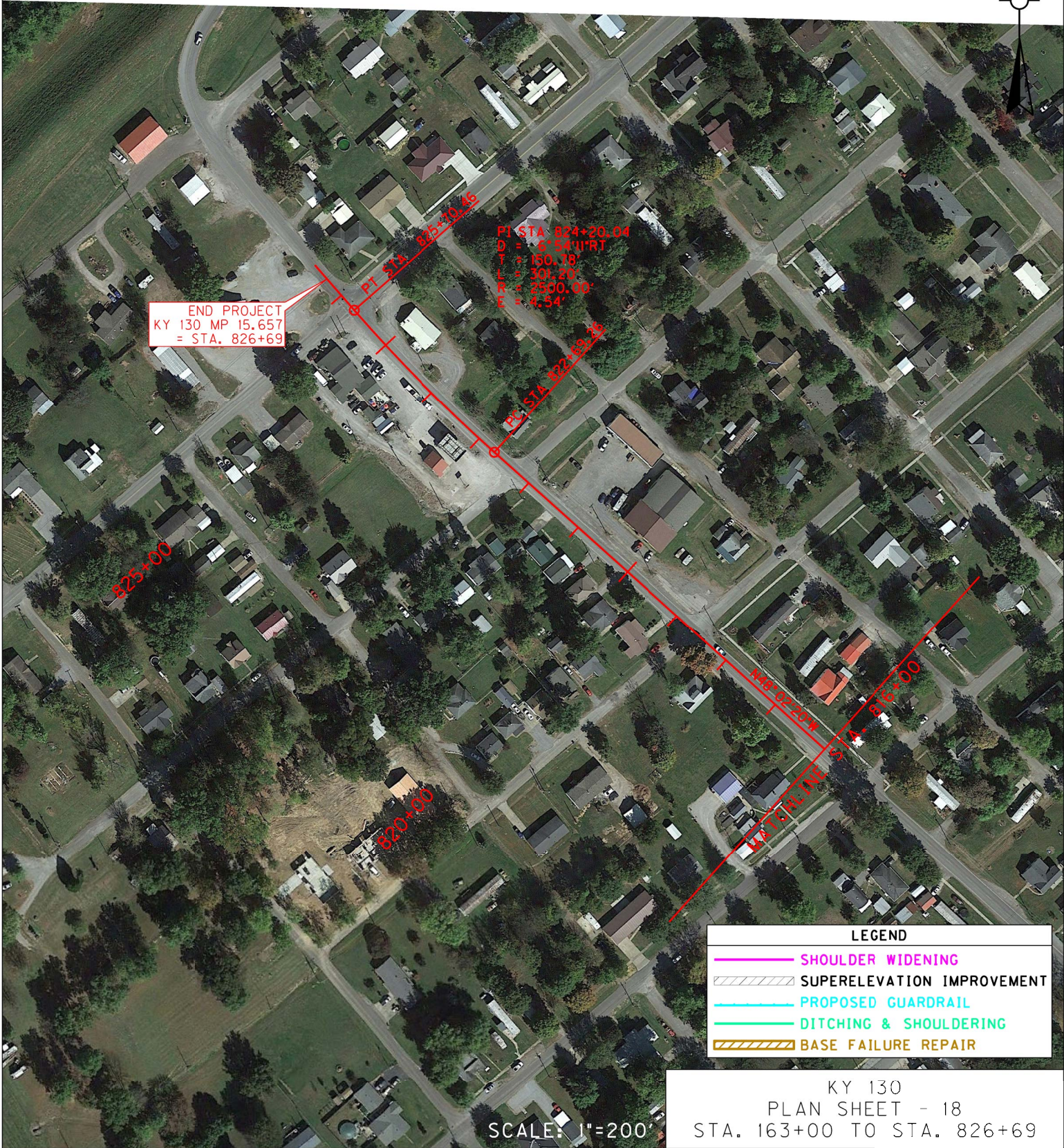

END PROJECT  
KY 130 MP 15.657  
= STA. 826+69

PI STA 824+20.04  
D = 47.54' (PIRT)  
T = 150.18'  
L = 301.20'  
E = 2500.00'  
F = 4.54'

LEGEND	
	SHOULDER WIDENING
	SUPERELEVATION IMPROVEMENT
	PROPOSED GUARDRAIL
	DITCHING & SHOULDERING
	BASE FAILURE REPAIR

SCALE: 1"=200'  
KY 130  
PLAN SHEET - 18  
STA. 163+00 TO STA. 826+69

SUPERELEVATION TRANSITION		
STA.	CROSS-SLOPE	
	SB LANE	NB LANE
605+71	EXISTING	EXISTING
606+16	2.0% (←)	FLAT
606+61	2.0% (←)	2.0% (←)
607+06	4.0% (←)	4.0% (←)
609+30	4.0% (←)	4.0% (←)
609+75	2.0% (←)	2.0% (←)
610+20	2.0% (←)	FLAT
610+65	EXISTING	EXISTING

COUNTY OF	ITEM NO.
UNION	2-9009.00

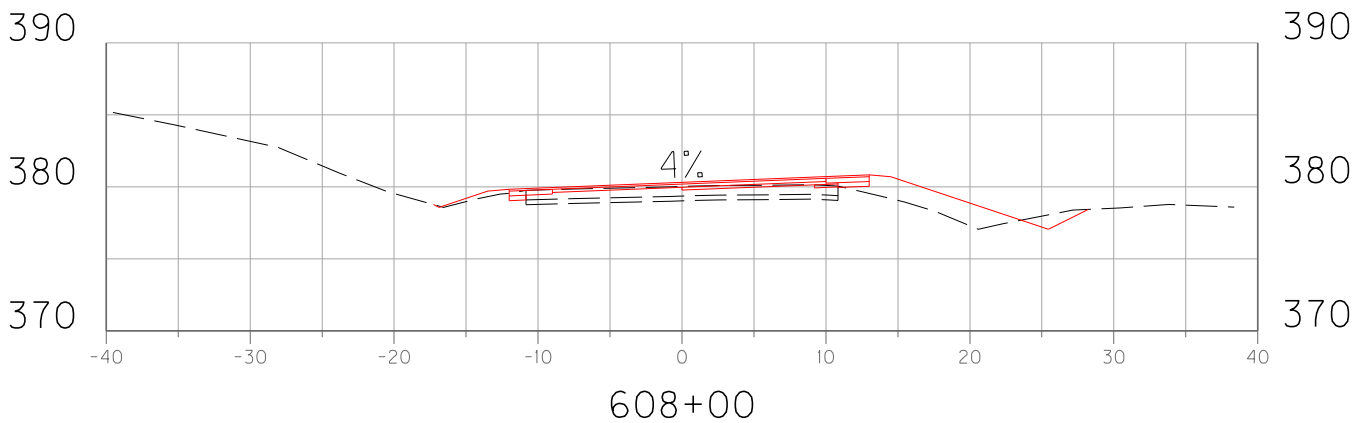
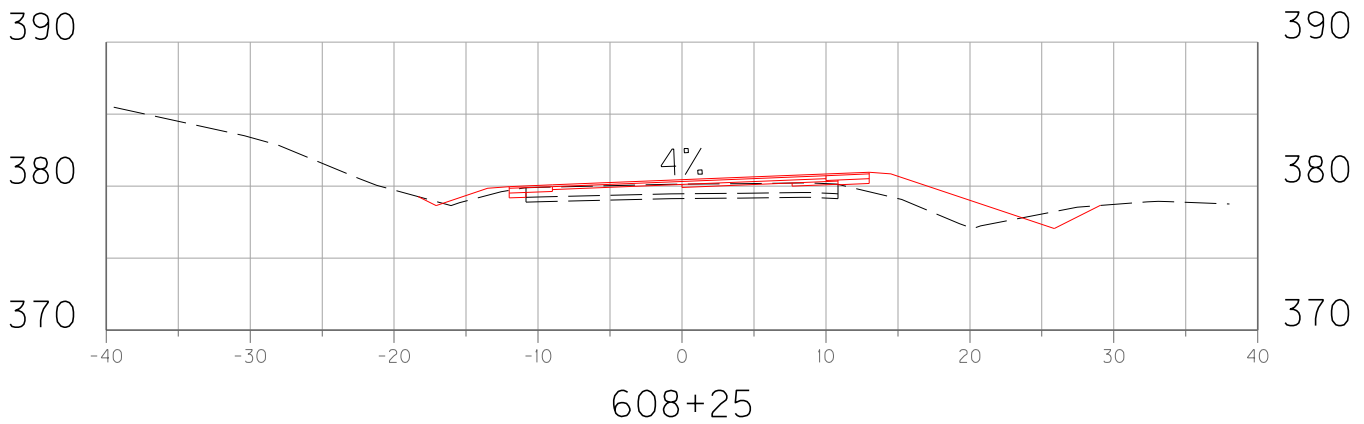
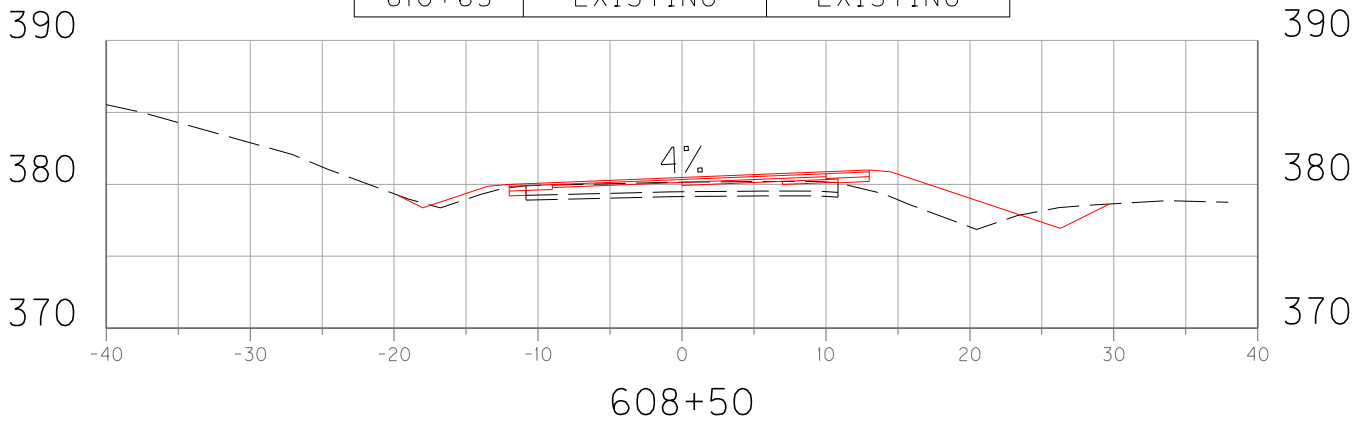

KY 130  
SUPERELEVATION DETAIL  
PI STA 608+18.33

SUPERELEVATION TRANSITION		
STA.	CROSS-SLOPE	
	SB LANE	NB LANE
665+29	EXISTING	EXISTING
665+74	FLAT	2.0% (→)
666+19	2.0% (→)	2.0% (→)
666+64	4.0% (→)	4.0% (→)
669+09	4.0% (→)	4.0% (→)
669+54	2.0% (→)	2.0% (→)
669+99	FLAT	2.0% (→)
670+44	EXISTING	EXISTING

COUNTY OF	ITEM NO.
UNION	2-9009.00

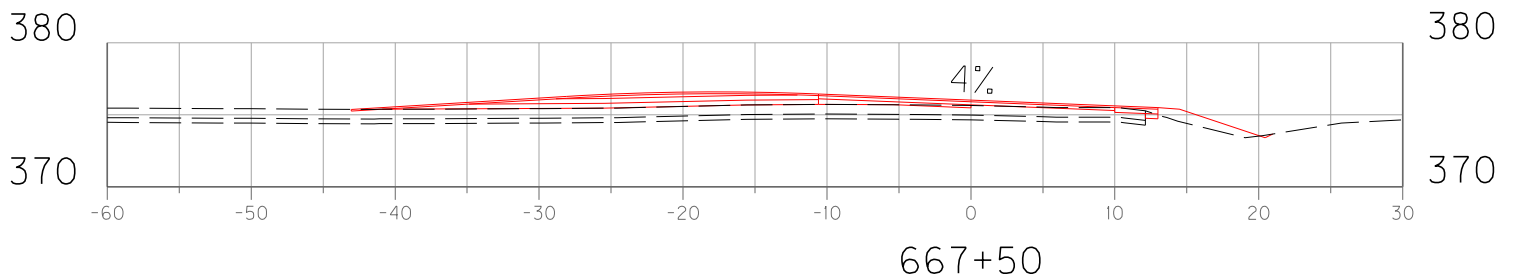
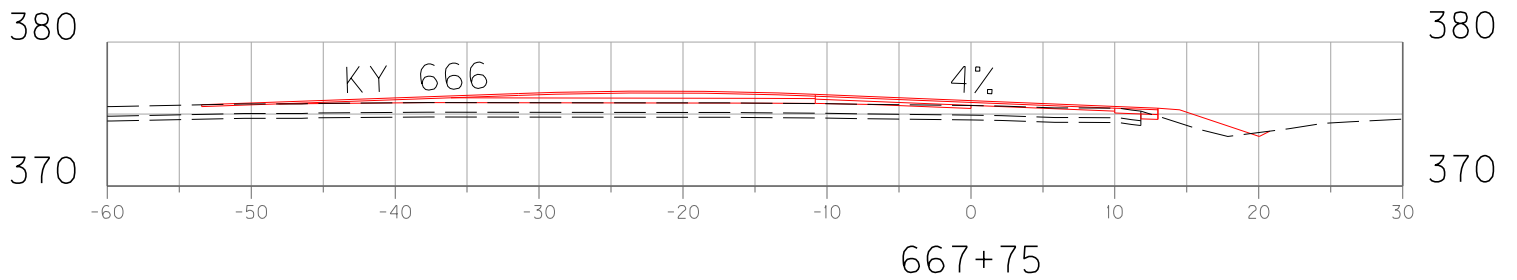
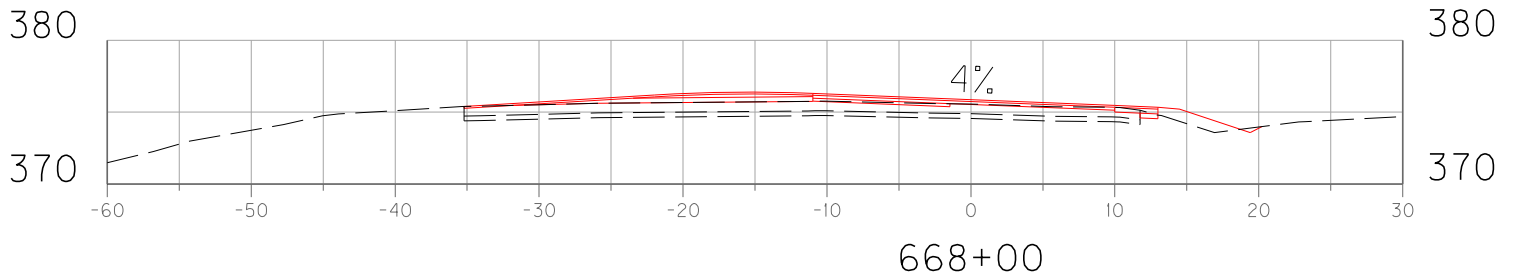

KY 130  
SUPERELEVATION DETAIL  
PI STA 667+87.68

SUPERELEVATION TRANSITION		
STA.	CROSS-SLOPE	
	SB LANE	NB LANE
750+04	EXISTING	EXISTING
751+04	2.0% (←)	2.0% (→)
751+44	2.0% (←)	FLAT
751+83	2.0% (←)	2.0% (←)
753+03	8.0% (←)	8.0% (←)
754+68	8.0% (←)	8.0% (←)
755+88	2.0% (←)	2.0% (←)
756+27	2.0% (←)	FLAT
756+67	EXISTING	EXISTING

COUNTY OF	ITEM NO.
UNION	2-9009.00

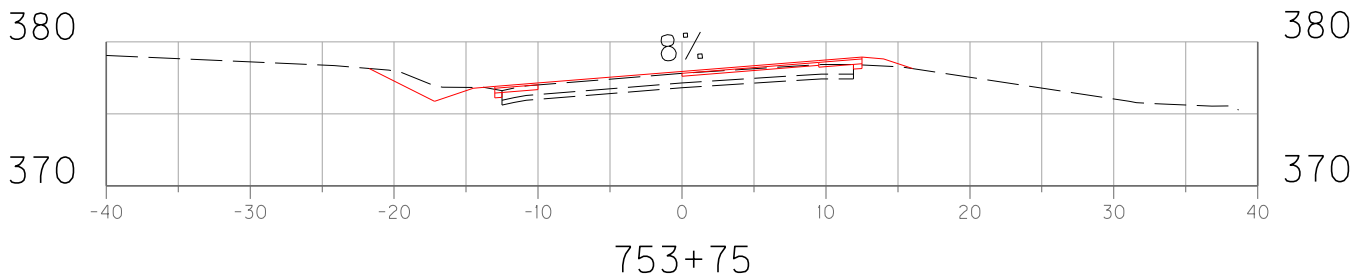
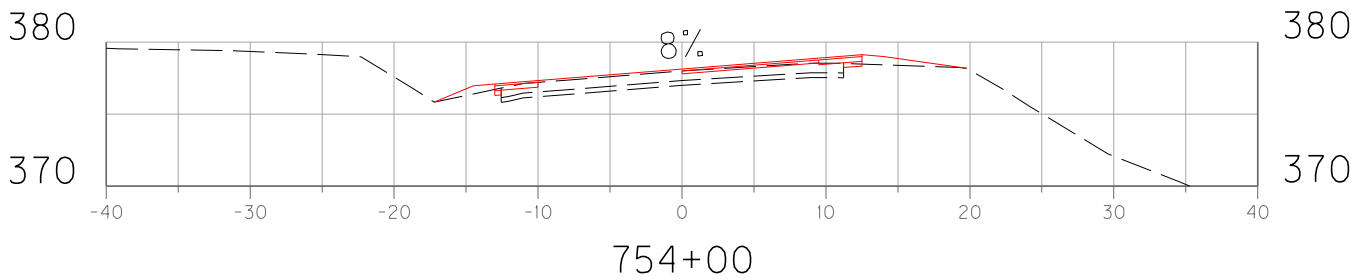
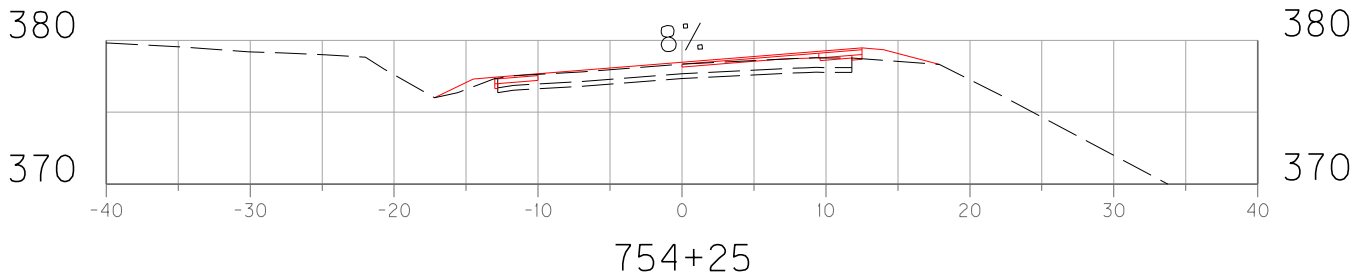

KY 130  
SUPERELEVATION DETAIL  
PI STA 753+90.21

COUNTY OF	ITEM NO.
UNION	2-9009.00

**NOTE:**

ALL JOINTS WHERE PROPOSED PIPE IS TO CONNECT WITH EXISTING PIPE SHALL BE ENCASED BY AN INTERMEDIATE ANCHOR. REFER TO THE PIPE REPLACEMENT AND EXTENSION SUMMARY FOR ESTIMATED QUANTITIES AND STANDARD DRAWING RDX-060-04 FOR DESIGN SPECIFICS.

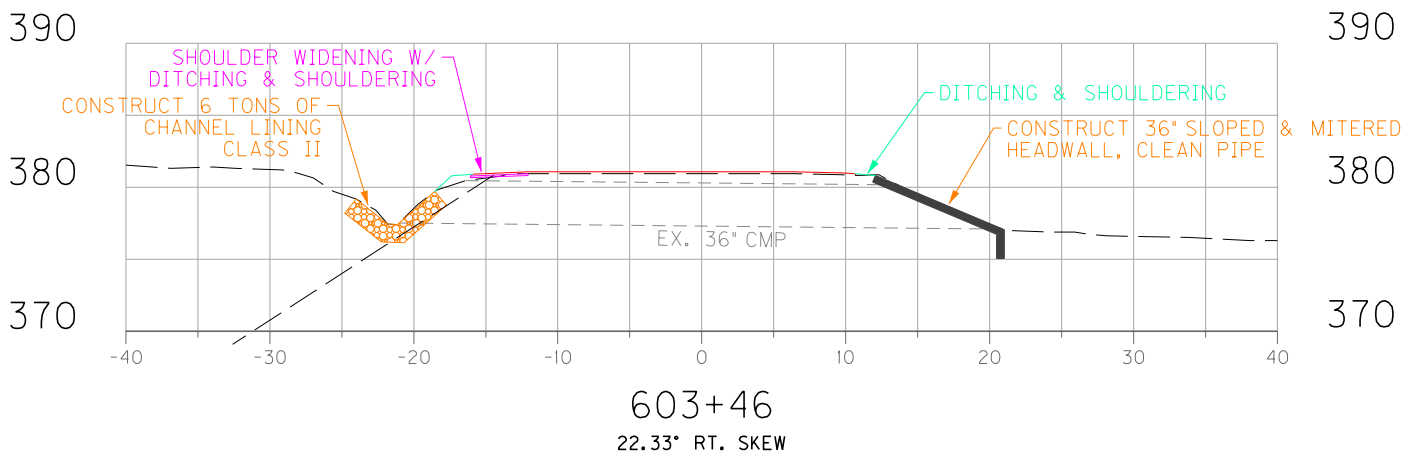
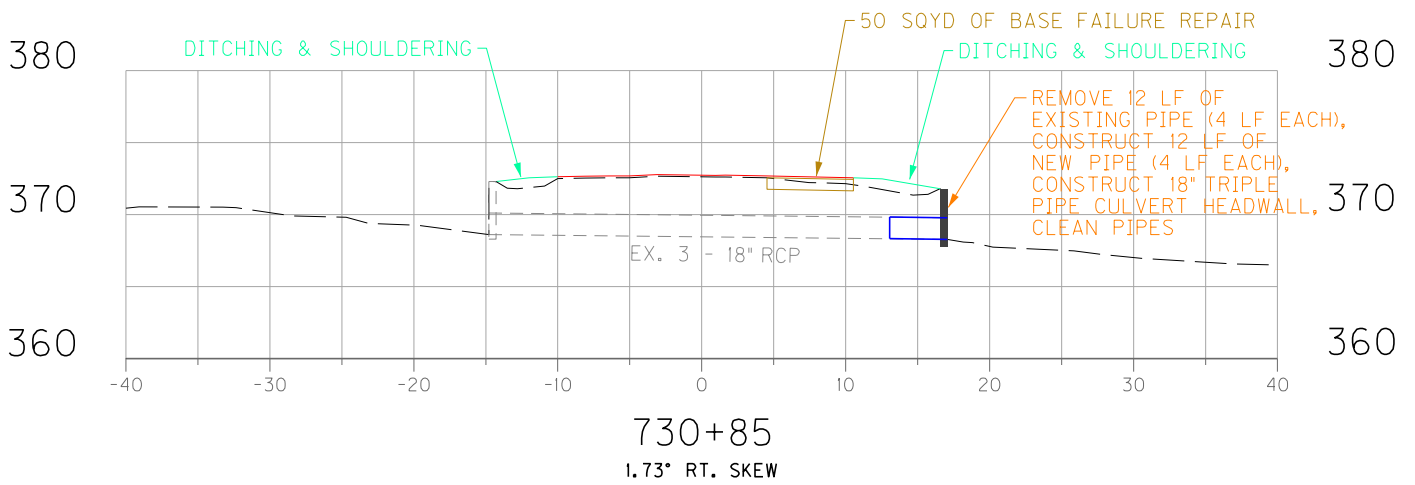
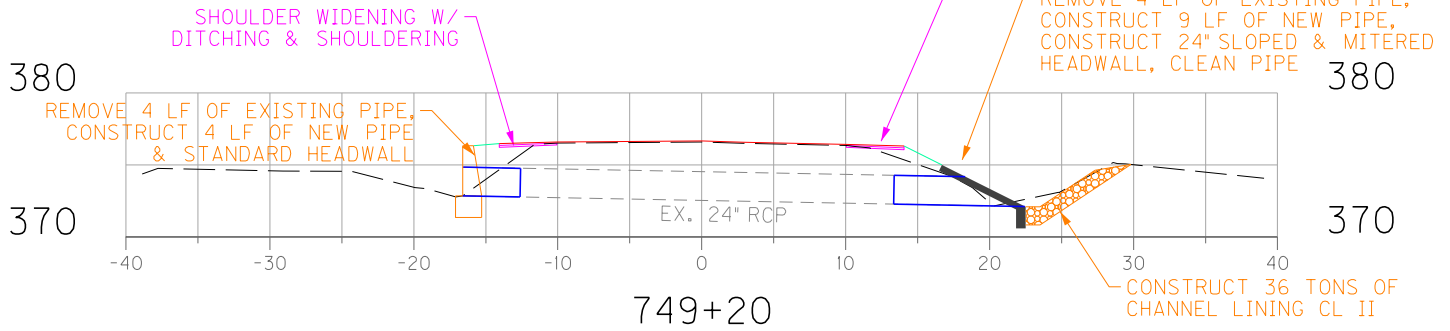

LEGEND	
<span style="color: blue;">—</span>	PROPOSED PIPE
<span style="color: red;">—</span>	PROPOSED PAVED SURFACE

KY 130  
PIPE SECTIONS

COUNTY OF	ITEM NO.
UNION	2-9009.00

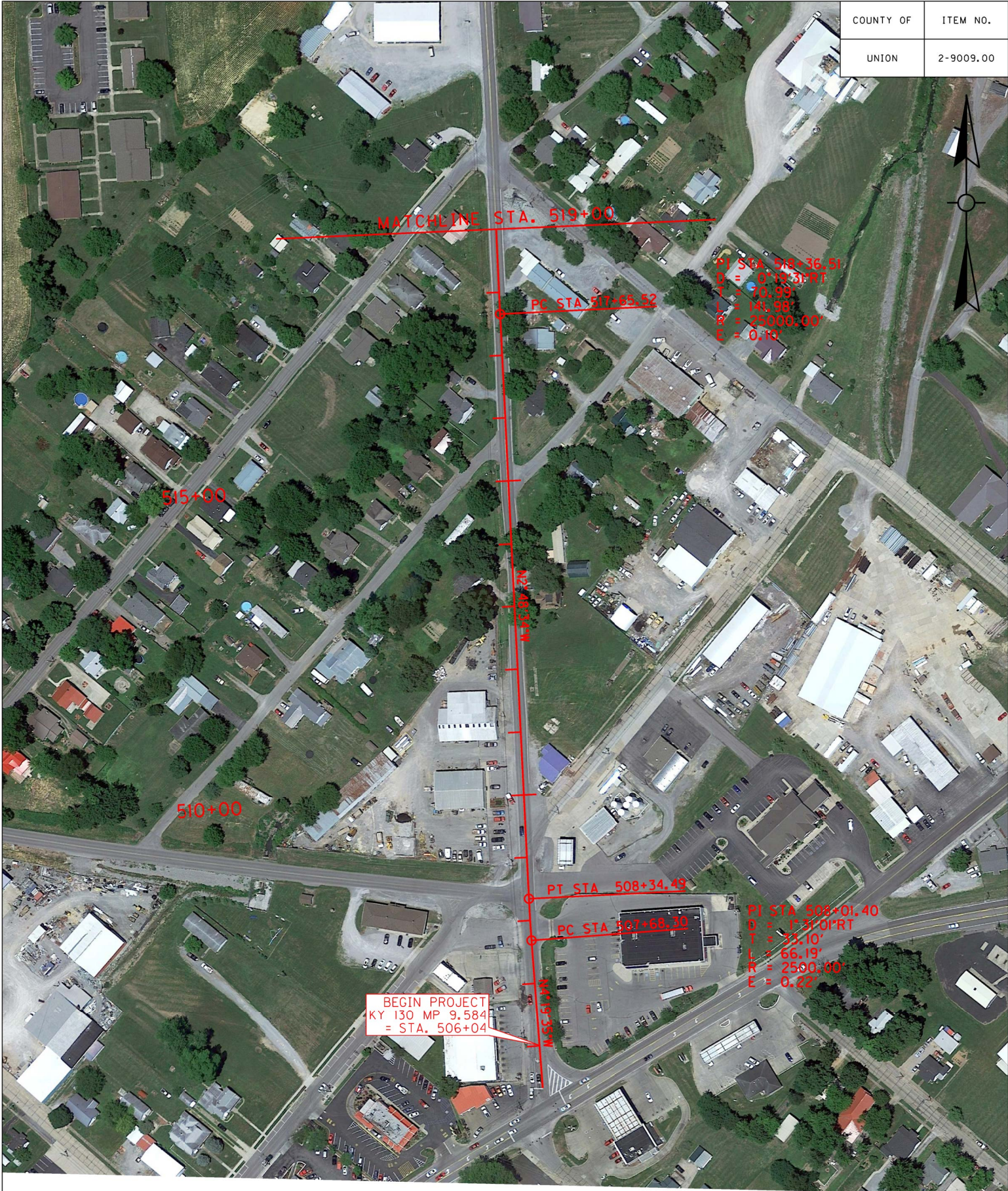

MATCHLINE STA. 519+00

PI STA 518+36.51  
 D = 6°13'31"RT  
 T = 30.99'  
 L = 141.98'  
 R = 25000.00'  
 E = 0.10'

PC STA 517+63.62

515+00

510+00

N27.48 S 52.71 W

N55.50 E 7.71 W

BEGIN PROJECT  
 KY 130 MP 9.584  
 = STA. 506+04

PT STA 508+34.49

PC STA 507+68.30

PI STA 508+01.40  
 D = 1°31'01"RT  
 T = 33.10'  
 L = 66.19'  
 R = 2500.00'  
 E = 0.22'

SCALE: 1"=200'

KY 130  
 SIGNING SHEET - 00  
 STA. 506+04 TO STA. 519+00



COUNTY OF	ITEM NO.
UNION	2-9009.00

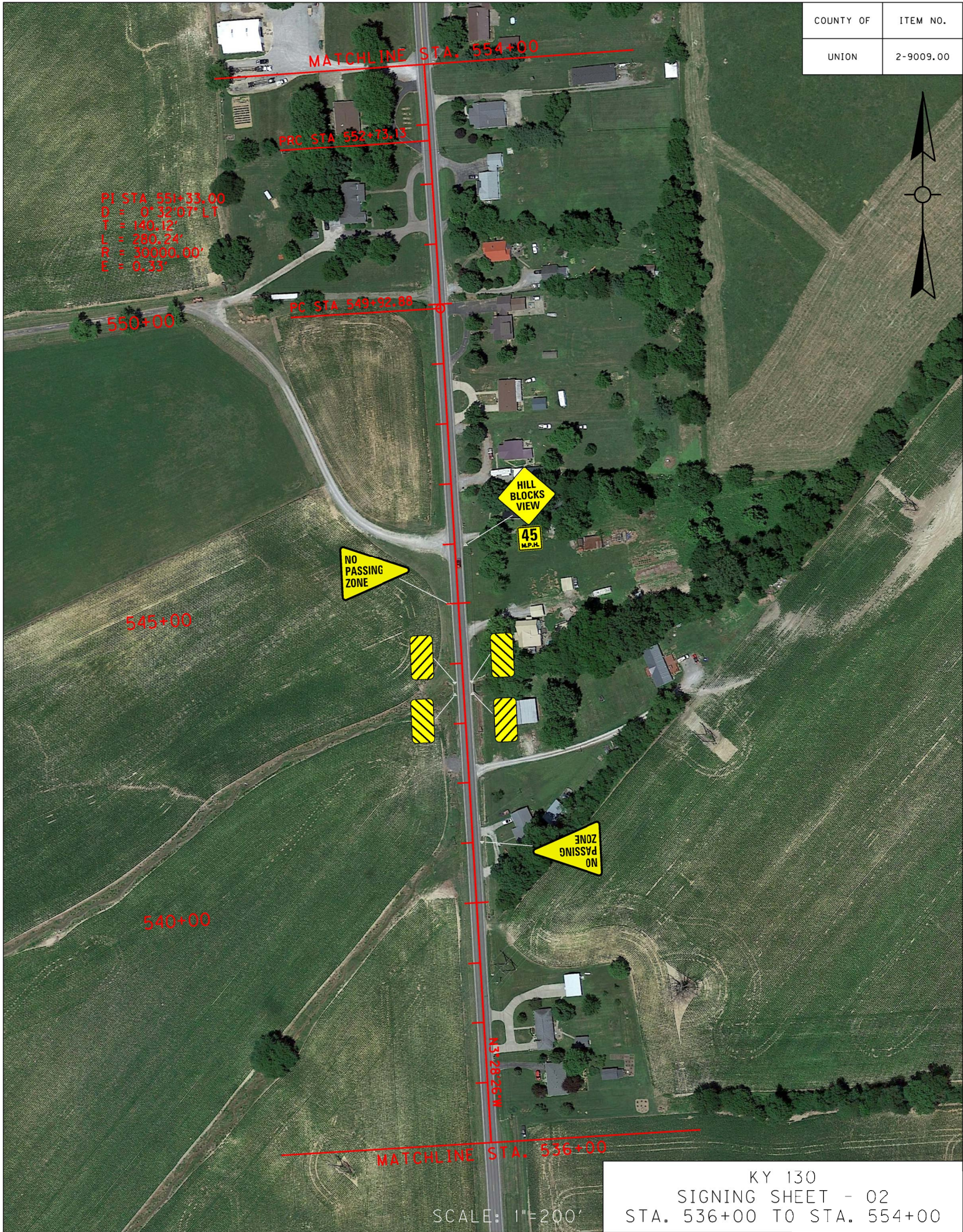

SCALE: 1"=200'  
KY 130  
SIGNING SHEET - 02  
STA. 536+00 TO STA. 554+00

COUNTY OF	ITEM NO.
UNION	2-9009.00

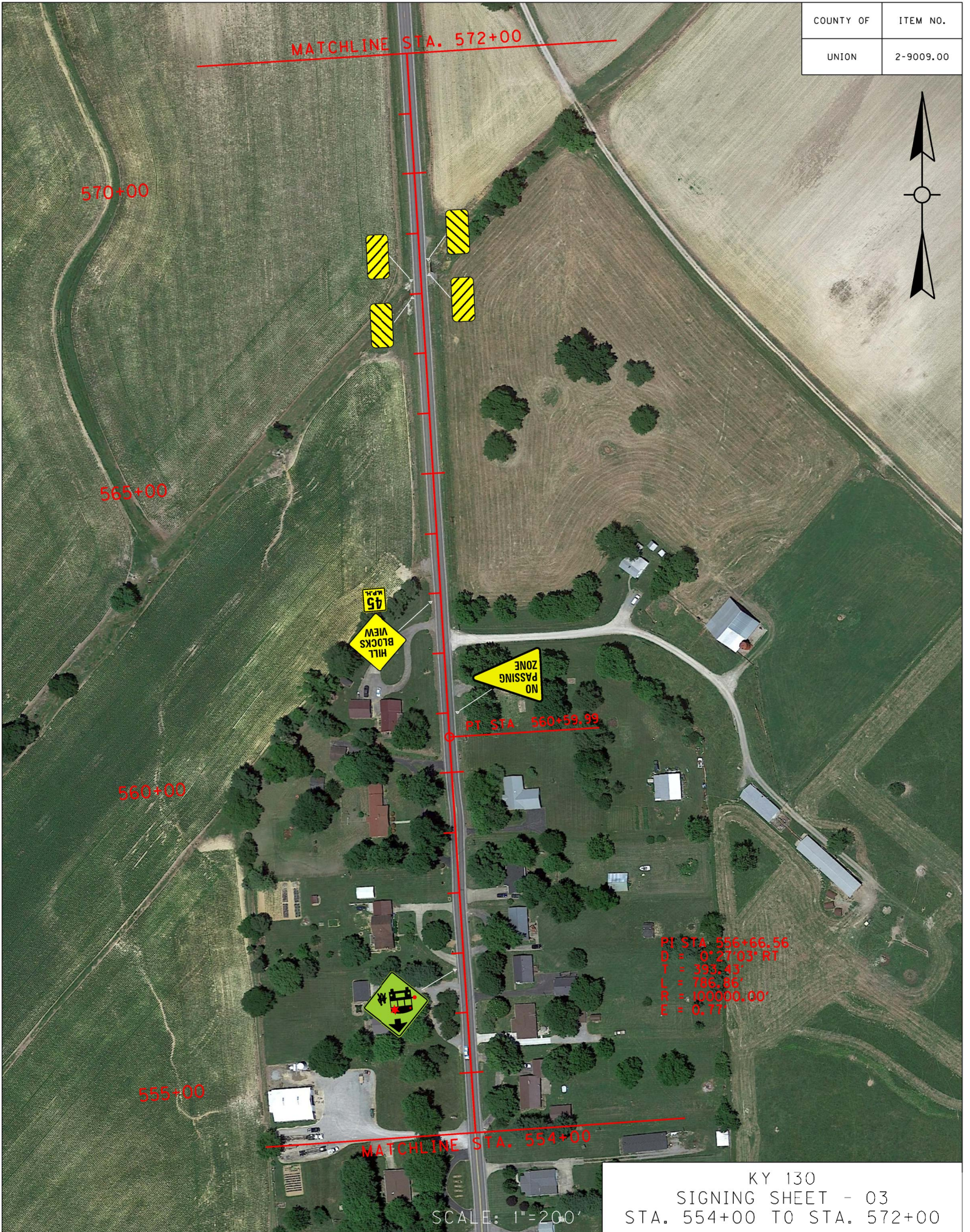

PT STA. 556+66.56  
D = 0° 21' 03" RT  
T = 333.43'  
L = 186.86'  
R = 100000.00'  
E = 0.77'

KY 130  
SIGNING SHEET - 03  
STA. 554+00 TO STA. 572+00

SCALE: 1"=200'

COUNTY OF	ITEM NO.
UNION	2-9009.00



KY 130  
SIGNING SHEET - 04  
STA. 572+00 TO STA. 590+00

SCALE: 1"=200'

COUNTY OF	ITEM NO.
UNION	2-9009.00

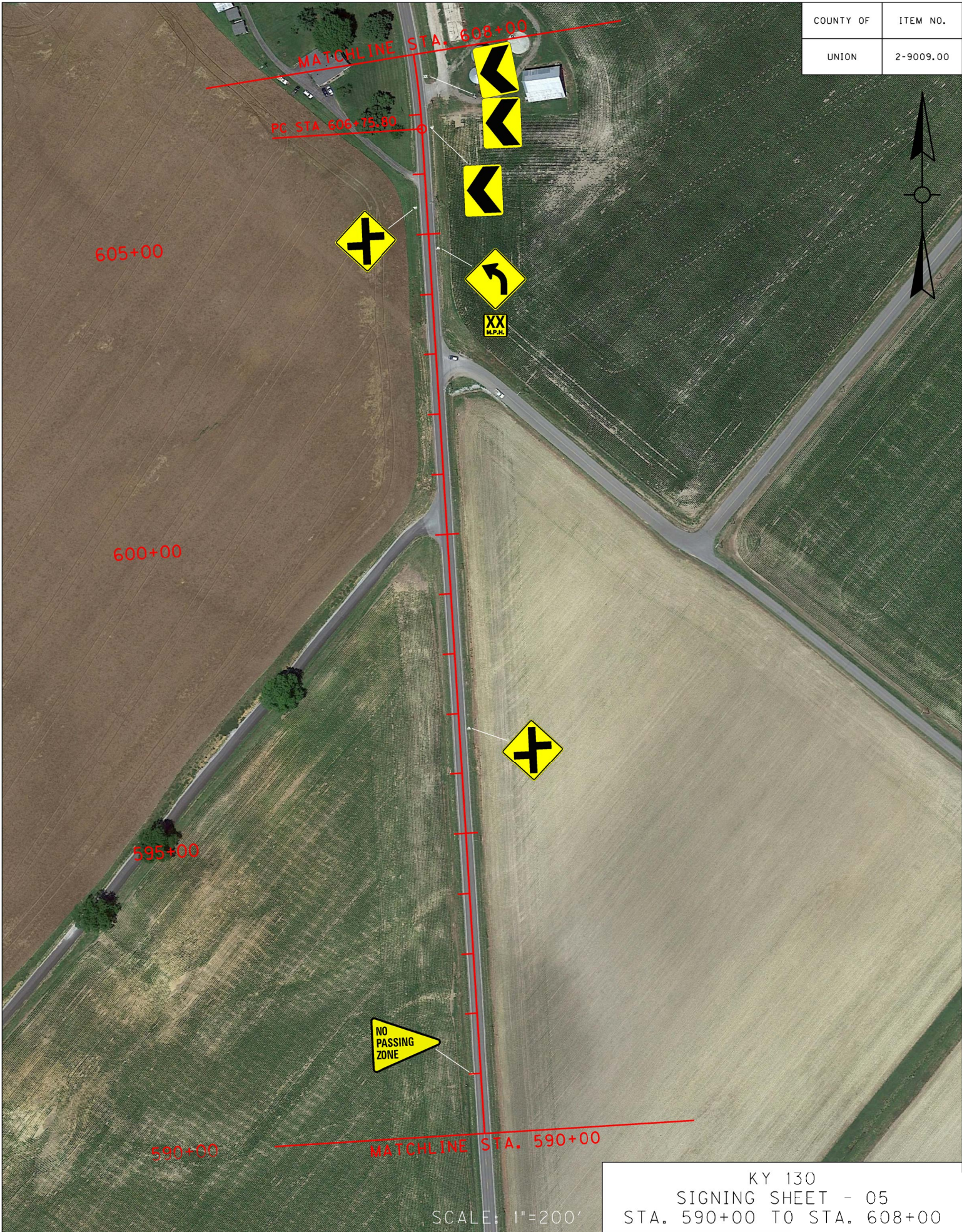

COUNTY OF	ITEM NO.
UNION	2-9009.00

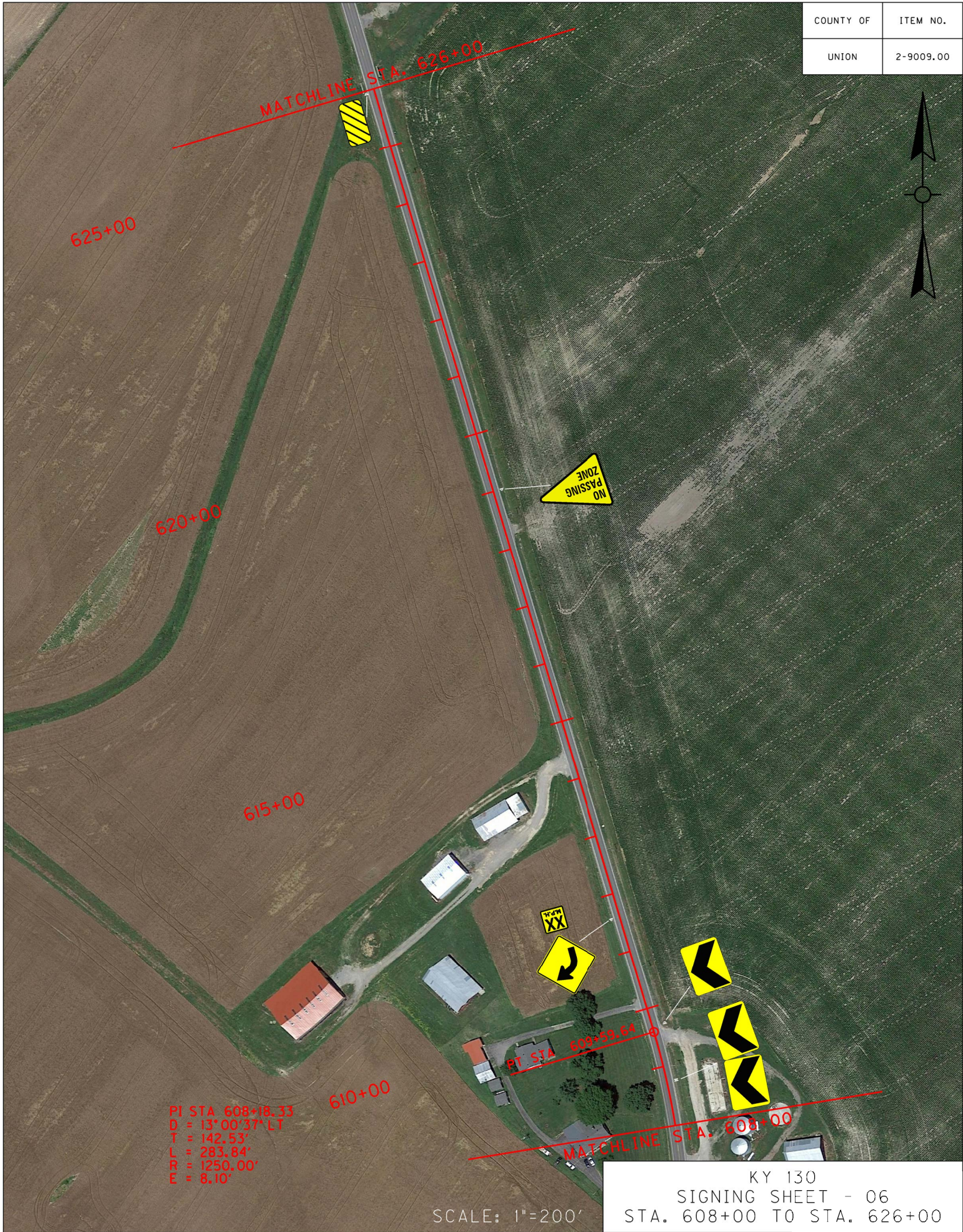

COUNTY OF	ITEM NO.
UNION	2-9009.00



SCALE: 1"=200'

KY 130  
SIGNING SHEET - 07  
STA. 626+00 TO STA. 644+00

COUNTY OF	ITEM NO.
UNION	2-9009.00



KY 130  
SIGNING SHEET - 08  
STA. 644+00 TO STA. 662+00

SCALE: 1"=200'

COUNTY OF	ITEM NO.
UNION	2-9009.00

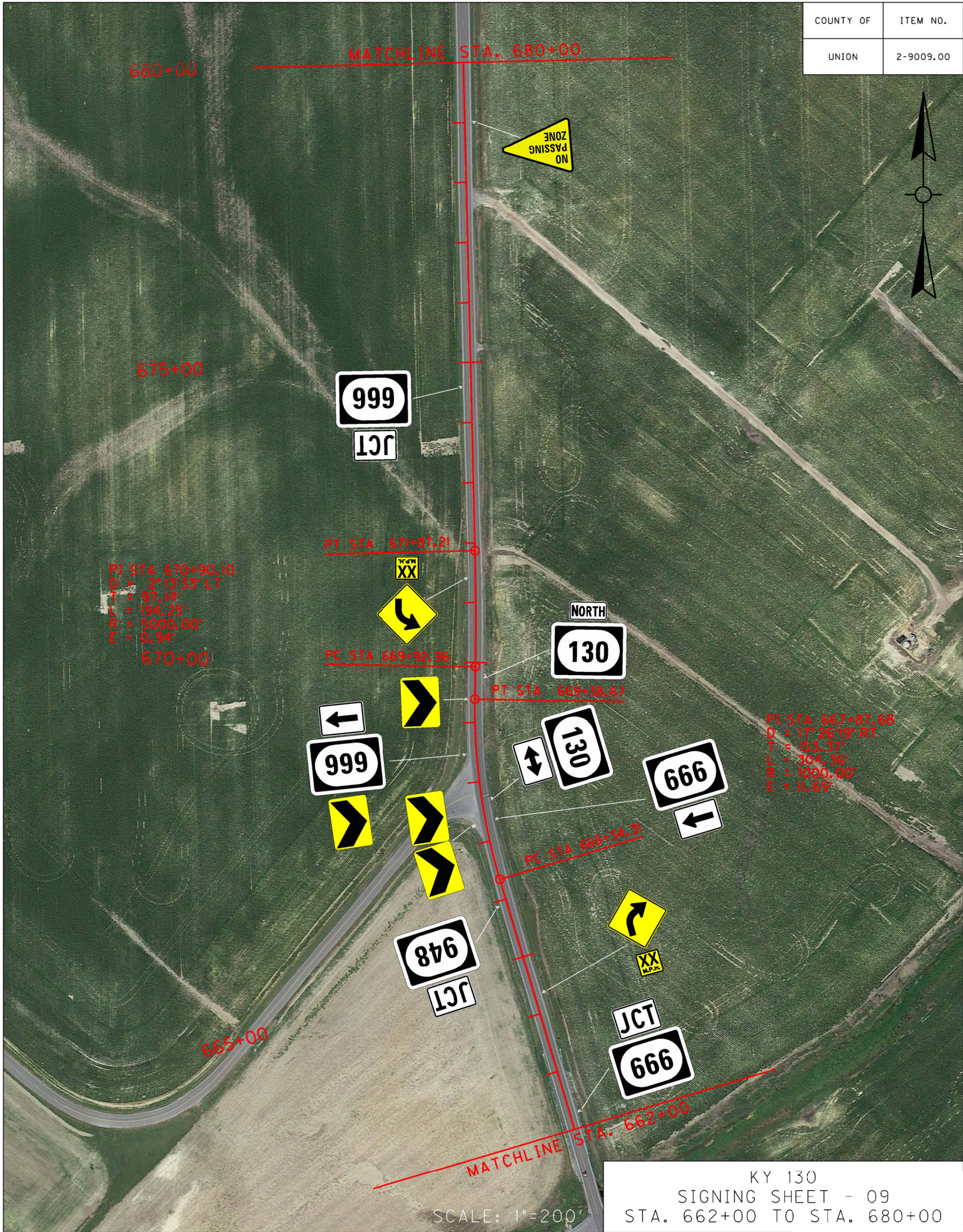

KY 130  
SIGNING SHEET - 09  
STA. 662+00 TO STA. 680+00

COUNTY OF	ITEM NO.
UNION	2-9009.00



PI STA. 697+31.08  
D = 2721'06" L.T  
T = 102.63  
L = 205.23  
R = 5000.00'  
E = 1.05'

PC STA 696+38.45

695+00

690+00

685+00

680+00

MATCHLINE STA. 698+00

MATCHLINE STA. 680+00

6-12-12

3 1  
MILE  
1 3  
MILE

KY 130  
SIGNING SHEET - 10  
STA. 680+00 TO STA. 698+00

SCALE: 1"=200'

COUNTY OF	ITEM NO.
UNION	2-9009.00

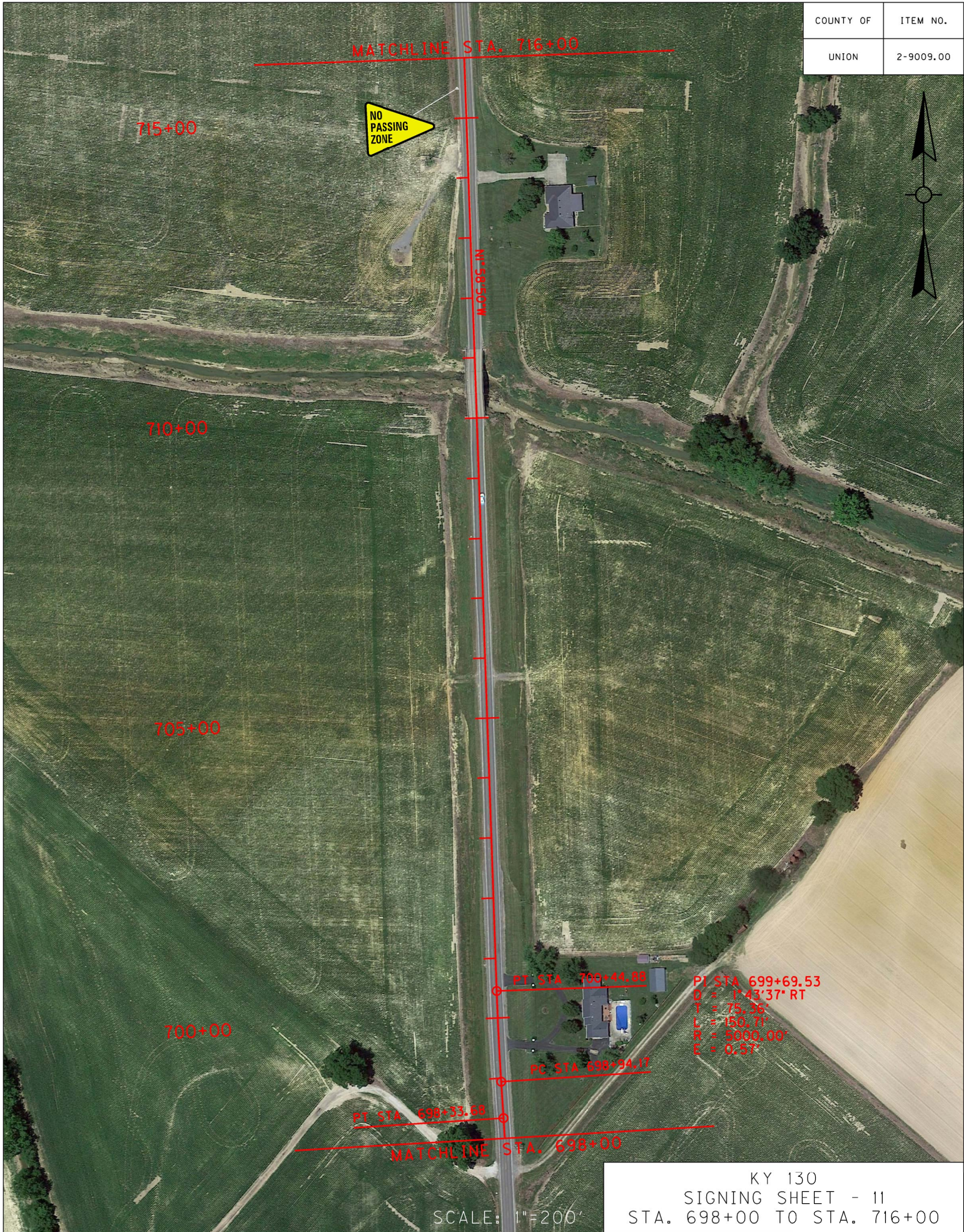

COUNTY OF	ITEM NO.
UNION	2-9009.00

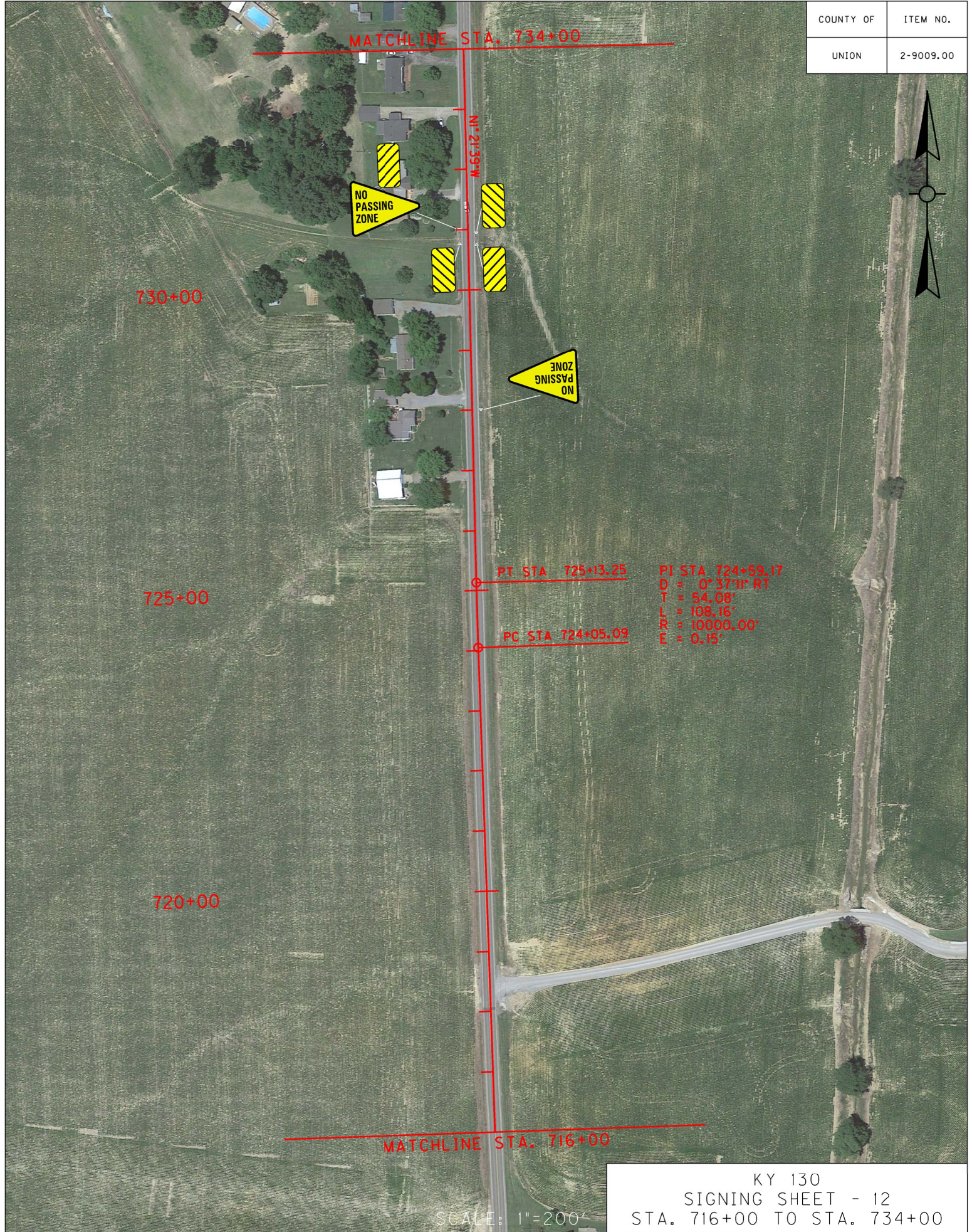

KY 130  
SIGNING SHEET - 12  
STA. 716+00 TO STA. 734+00

SCALE: 1"=200'

COUNTY OF	ITEM NO.
UNION	2-9009.00

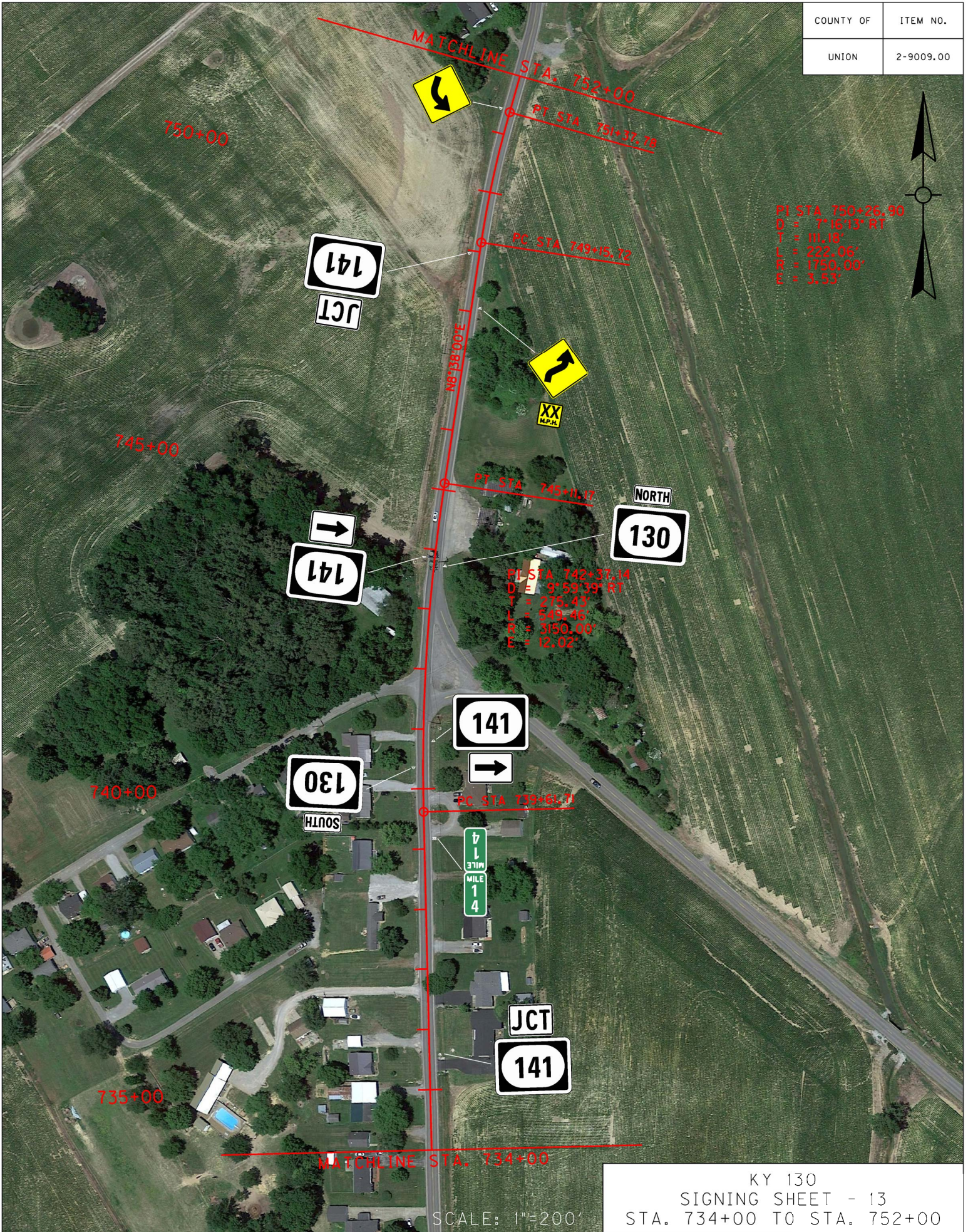

PI STA 750+35.90  
 D = 7°16'13" RT  
 T = 111.18'  
 L = 232.06'  
 E = 1750.00'  
 E = 3.53'

PI STA 742+37.14  
 D = 9°59'39" RT  
 T = 215.47'  
 L = 349.48'  
 E = 3150.00'  
 E = 12.02'

KY 130  
 SIGNING SHEET - 13  
 STA. 734+00 TO STA. 752+00

SCALE: 1"=200'

COUNTY OF	ITEM NO.
UNION	2-9009.00

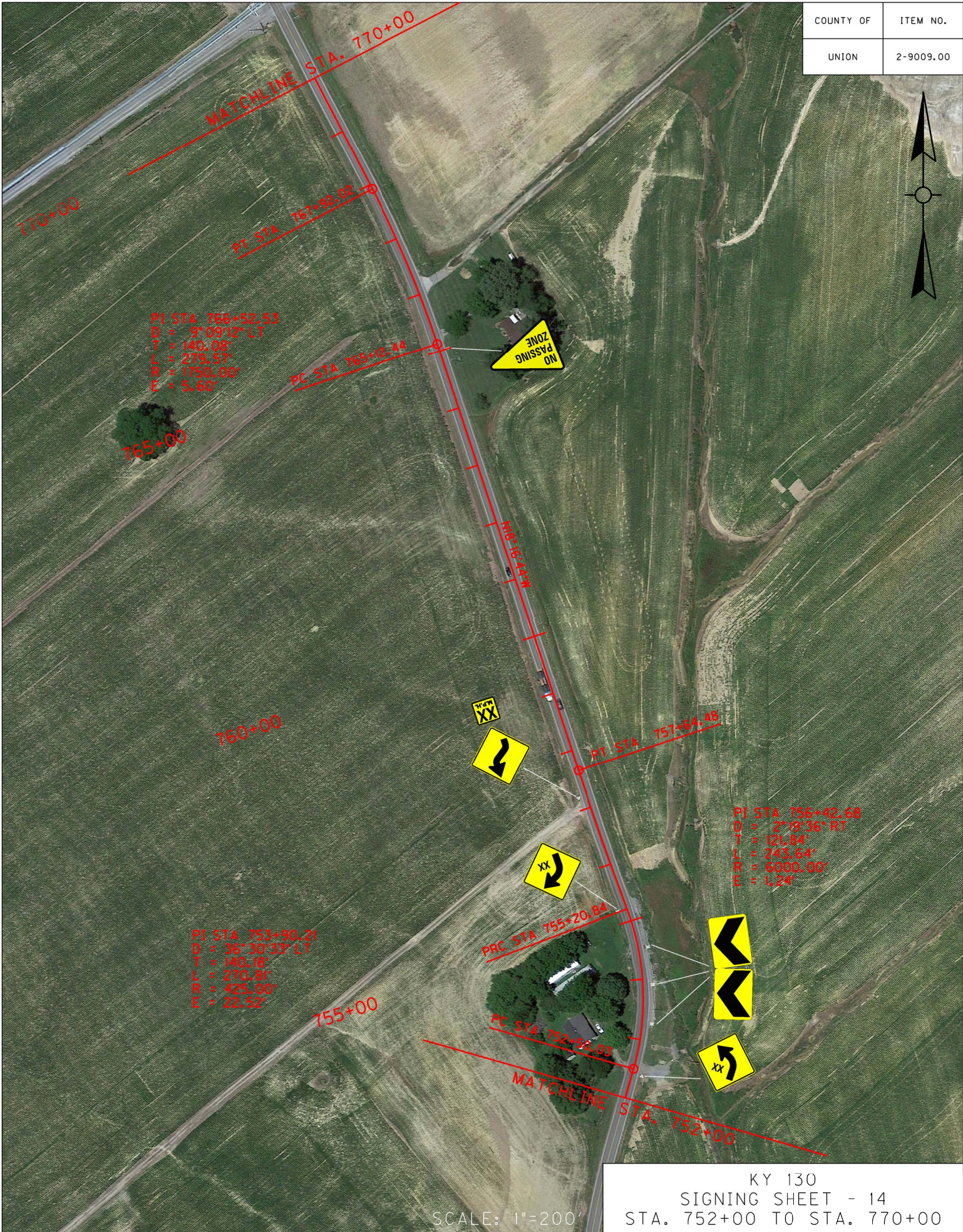

PI STA 766+52.53  
 D = 9°09'12" LT  
 T = 140.08  
 L = 273.57  
 R = 1753.00'  
 E = 5.50

PI STA 753+90.21  
 D = 36°10'37" LT  
 T = 193.18  
 L = 273.81  
 R = 425.00'  
 E = 23.52

PI STA 755+42.68  
 D = 2°09'36" RT  
 T = 121.84  
 L = 343.54  
 R = 6000.00'  
 E = 1.24

KY 130  
 SIGNING SHEET - 14  
 STA. 752+00 TO STA. 770+00

SCALE: 1"=200'

COUNTY OF	ITEM NO.
UNION	2-9009.00

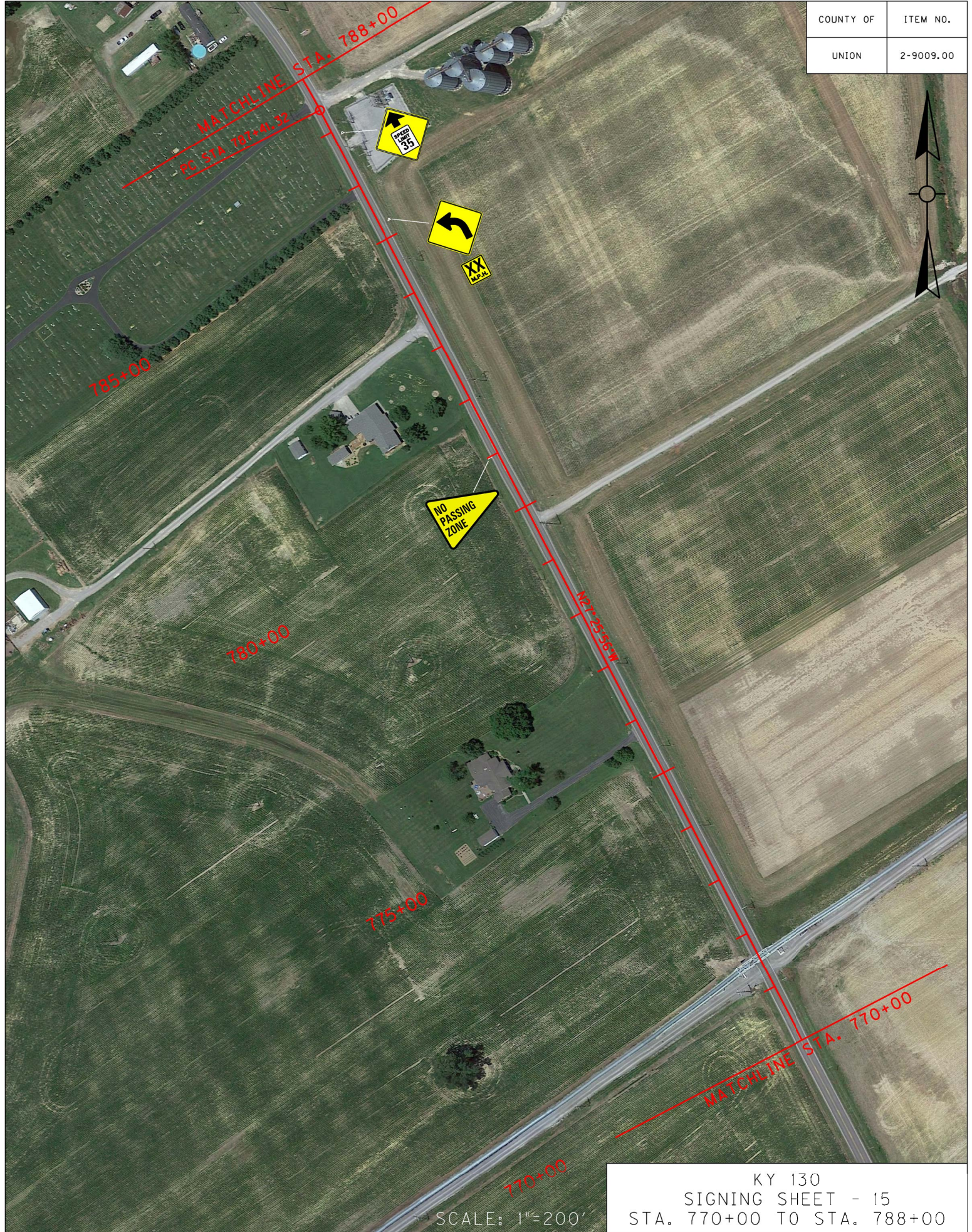

SCALE: 1"=200'  
KY 130  
SIGNING SHEET - 15  
STA. 770+00 TO STA. 788+00

COUNTY OF	ITEM NO.
UNION	2-9009.00

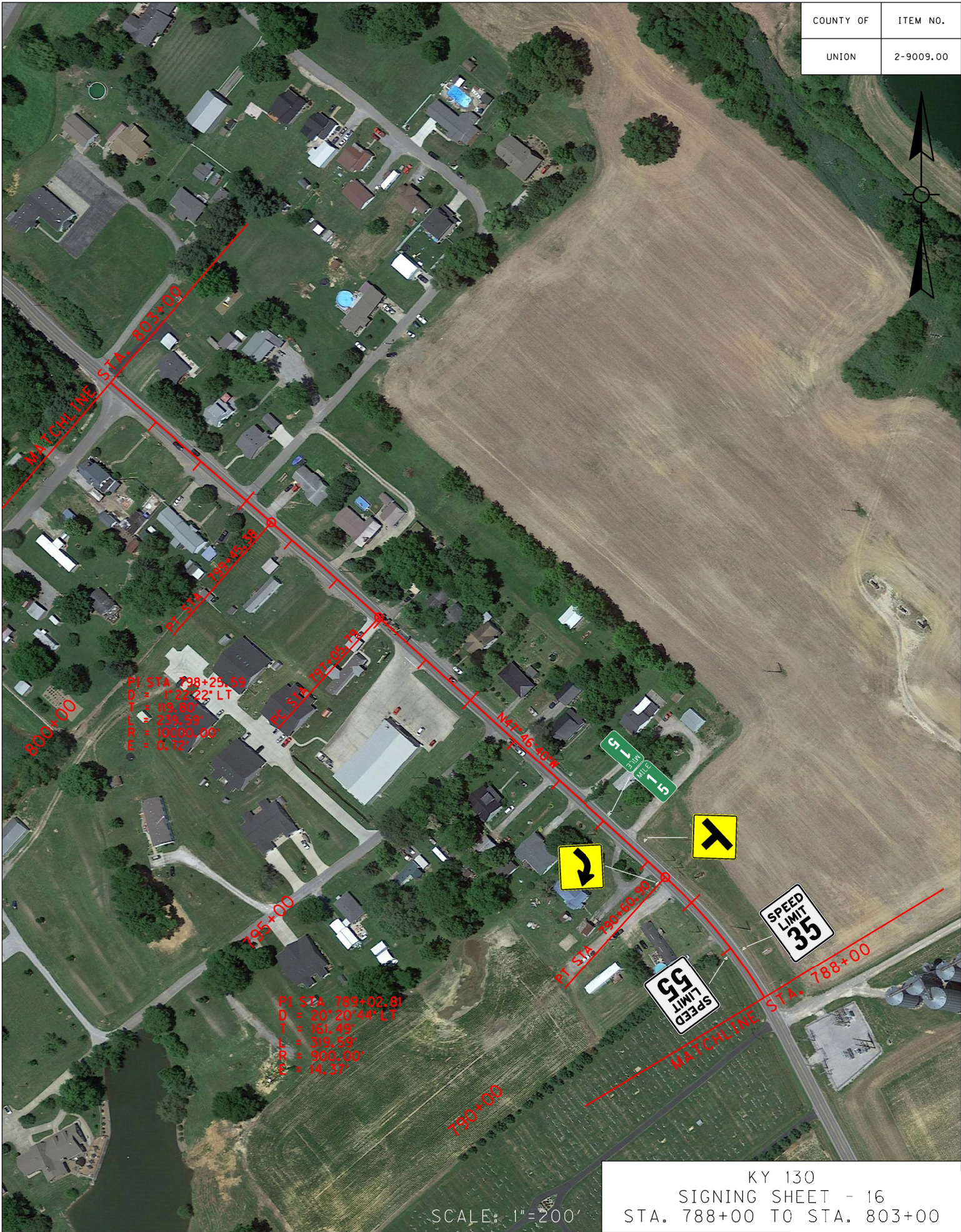

PI STA 798+25.59  
 D = 122.22' LT  
 L = 119.80'  
 T = 235.53'  
 P = 3089.05'  
 E = 0.72'

PI STA 799+02.81  
 D = 20' 20.44" LT  
 L = 161.49'  
 T = 319.59'  
 P = 908.00'  
 E = 14.37'

SCALE: 1"=200'  
 KY 130  
 SIGNING SHEET - 16  
 STA. 788+00 TO STA. 803+00

COUNTY OF	ITEM NO.
UNION	2-9009.00

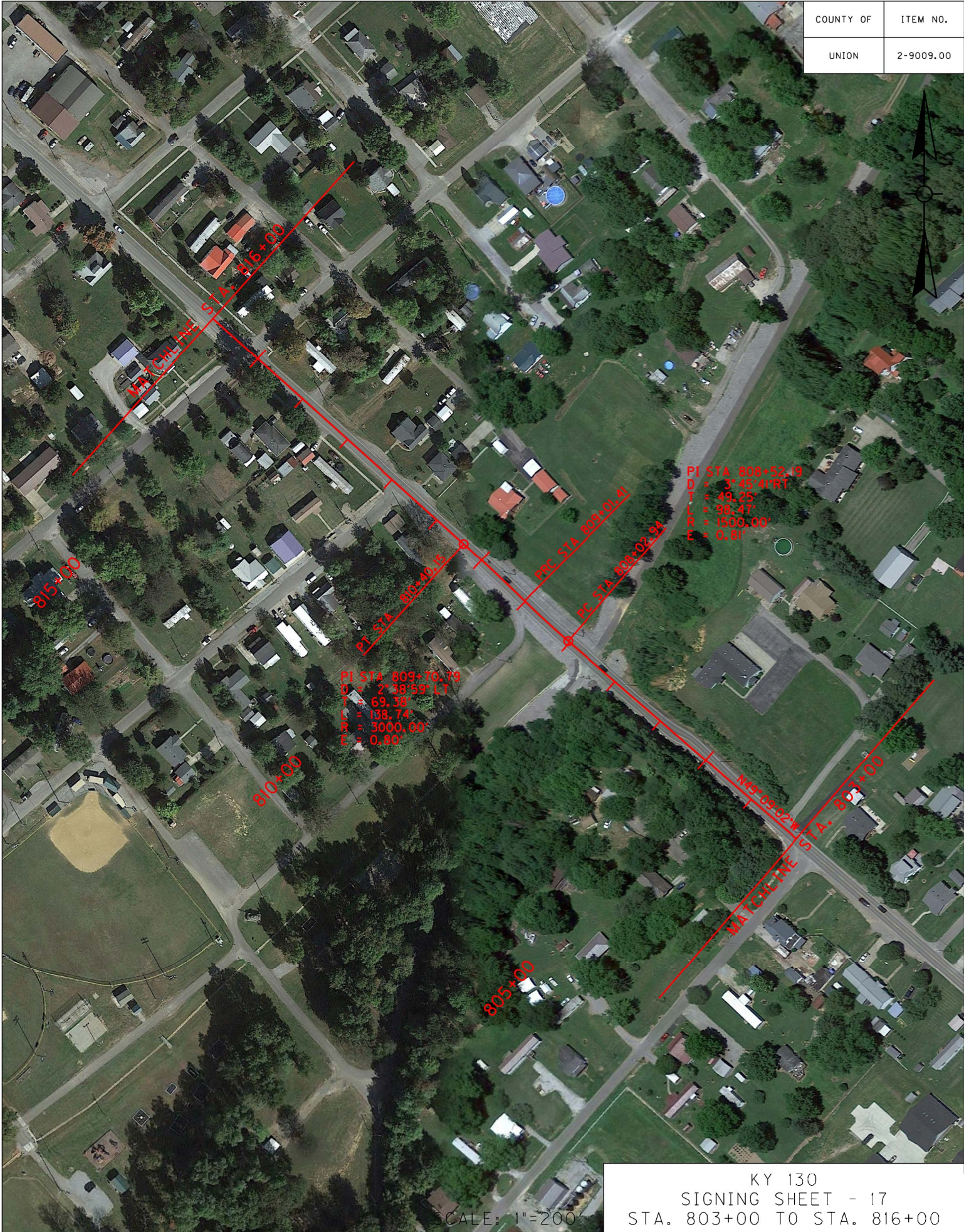

PI STA. 809+76.79  
D = 2° 38' 59" LT  
L = 69.30  
K = 138.74  
R = 3000.00'  
E = 0.80'

PI STA. 808+52.19  
D = 3° 43' 41" RT  
L = 49.25  
K = 98.47  
R = 1530.00'  
E = 0.81'

SCALE: 1"=200'  
KY 130  
SIGNING SHEET - 17  
STA. 803+00 TO STA. 816+00

COUNTY OF	ITEM NO.
UNION	2-9009.00

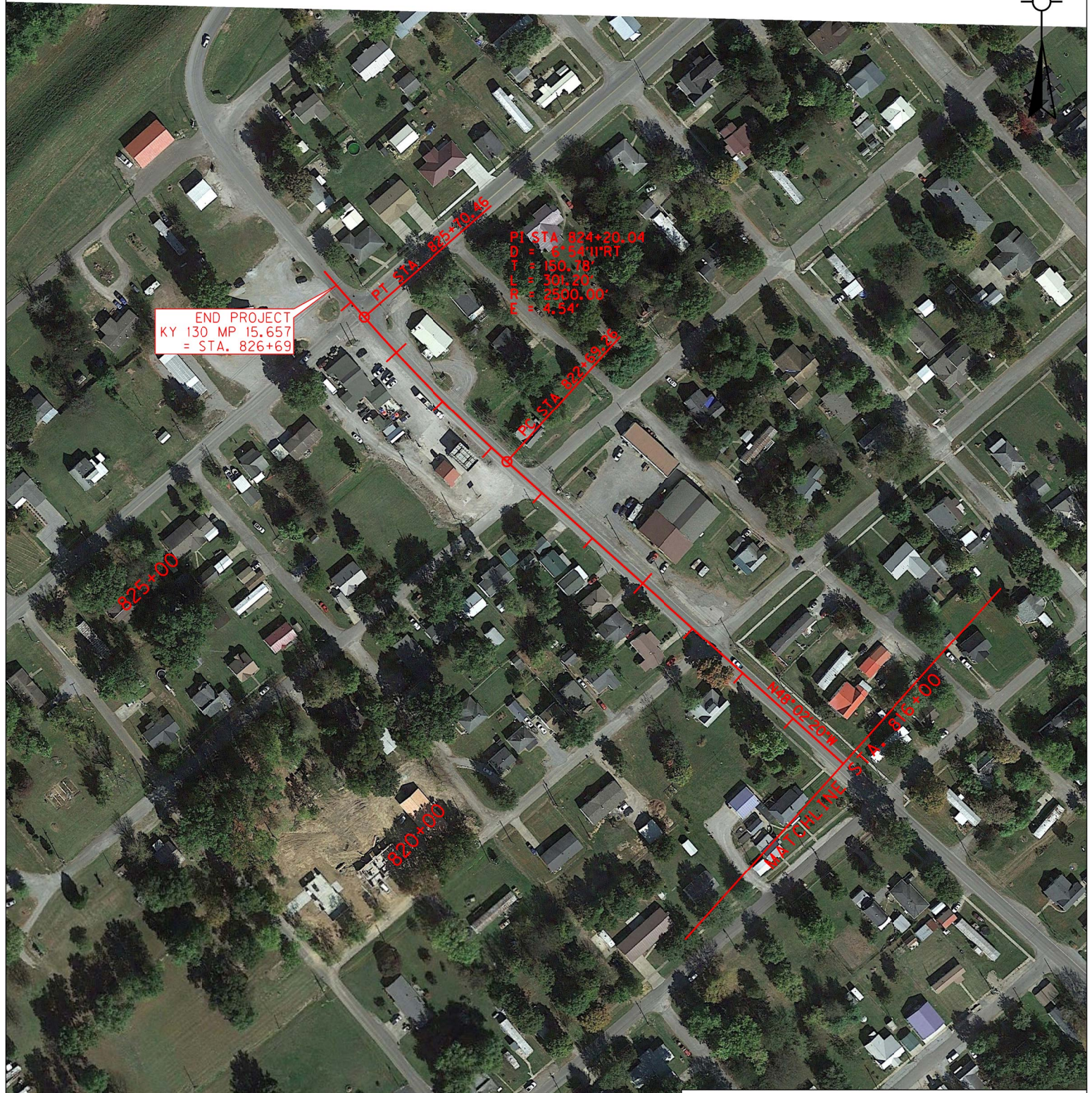

END PROJECT  
KY 130 MP 15.657  
= STA. 826+69

PI STA. 824+20.04  
D = 47.5411RT  
T = 150.18  
L = 301.20  
R = 2500.00  
E = 4.54

825+00

820+00

815+00

810+00

SCALE: 1"=200'

KY 130  
SIGNING SHEET - 18  
STA. 163+00 TO STA. 826+69

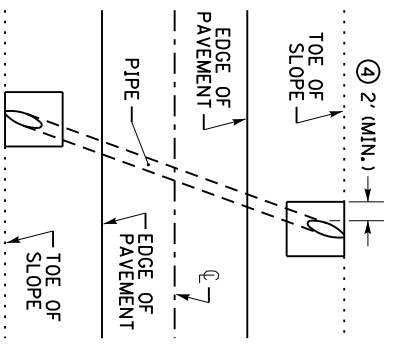
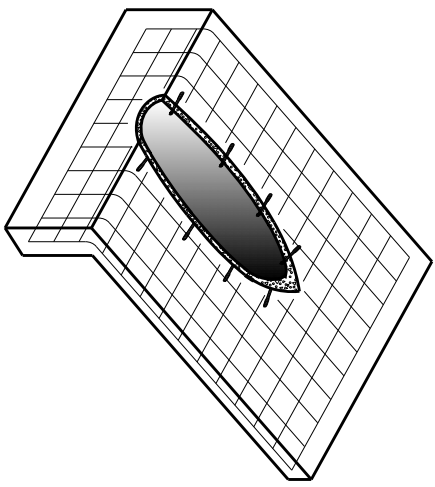
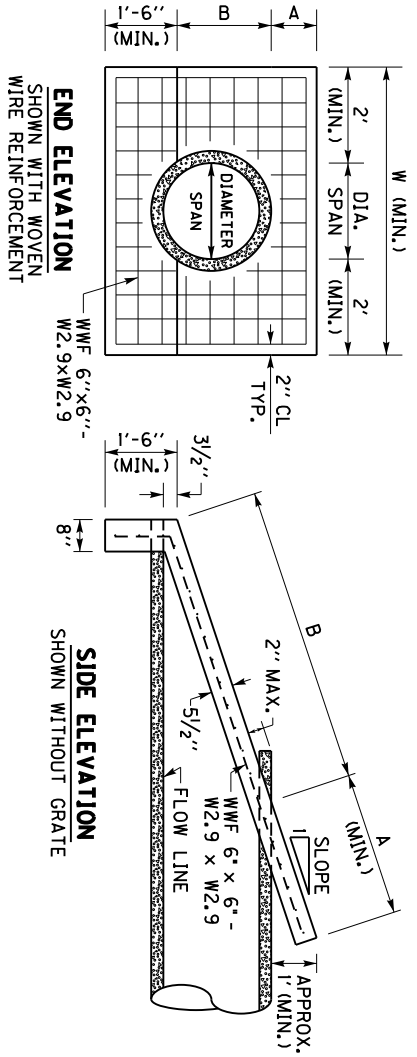

**ISOMETRIC VIEW**  
SHOWN WITH WOVEN  
WIRE REINFORCEMENT  
AND WEDGE ANCHORS

**PLAN VIEW**  
SHOWN WHEN THE  
PIPE IS ON A SKEW

DIMENSIONS AND CONCRETE QUANTITIES (FOR PIPE WITH SKEW = 0°) ④

PIPE SIZE	3:1 SLOPE			4:1 SLOPE			6:1 SLOPE		
	A	B	W	A	B	W	A	B	W
15"	3'-7 1/2"	5'-3"	0.74	4'-8 3/4"	5'-3"	0.93	6'-11 3/4"	5'-3"	1.29
18"	4'-5 3/4"	5'-6"	0.85	5'-10"	5'-6"	1.05	8'-7 1/4"	5'-6"	1.48
24"	6'-2 1/2"	6'-0"	1.05	8'-1"	6'-0"	1.32	11'-11"	6'-0"	1.87
30"	7'-10 3/4"	6'-6"	1.43	10'-3 3/4"	6'-6"	1.80	15'-2 1/2"	6'-6"	2.28

④ DIMENSIONS AND CONCRETE QUANTITIES ARE APPROXIMATE AND LISTED FOR INFORMATIONAL PURPOSES ONLY. \*\*

BID ITEM AND UNIT TO BID: 24575ES610 HEADWALL (SLOPED & MITERED CONCRETE-FOR 1/2 INCH PIPE) - EACH

COUNTY OF	TOWN OF	SHEET NO.
-----------	---------	-----------

- ~ NOTES ~
- FOR PIPES THAT RECEIVE THE SLOPED & MITERED CONCRETE HEADWALL, THE PIPE LENGTH SHALL BE MEASURED TO THE FURTHEST POINT ALONG THE MITERED END OF THE PIPE.
  - THE EMBANKMENT FILL MATERIAL IS TO BE PLACED, COMPACTED, AND GRADDED AROUND THE PIPE BEFORE THE CONCRETE SLOPE PAVING IS PLACED. THE INTENT IS FOR THE SLOPED & MITERED HEADWALL TO MATCH THE FINAL EMBANKMENT SLOPE.
  - THE PIPE SHALL BE MITERED AFTER THE CONCRETE SLOPE PAVING HAS BEEN PLACED AND SUFFICIENTLY CURED. THE PIPE SHOULD BE MITERED AS CLOSE TO FLUSH WITH THE SLOPE PAVING AS POSSIBLE, AND NO HIGHER THAN 2" ABOVE THE SLOPE PAVING. HAND FINISHING AND/OR CUTTING MAY BE NECESSARY.
  - WHEN THE PIPE IS ON A SKEW, INSTALL THE HEADWALL AND MITER THE PIPE SO THAT THE CONCRETE SLOPE PAVING IS PERPENDICULAR TO THE ROADWAY. FOR HEADWALLS ON SKEWED PIPES, THE HEADWALL WIDTH, 'W', SHALL BE WIDENED, AS NEEDED, SO THAT THE OUTSIDE EDGE OF THE CONCRETE SLOPE PAVING IS A MINIMUM OF 2" FROM THE OUTER MOST EDGE OF THE PIPE.
  - THE DIMENSION 'A' IS BASED ON THE FINAL GRADED SLOPE. THE DIMENSION 'B' IS BASED ON CIRCULAR REINFORCED CONCRETE PIPE AT 0° SKEW FOR THE LISTED SLOPE. THE DIMENSION 'W' IS BASED ON THE DIAMETER, OR SPAN, OF THE PIPE. THE FINAL HEADWALL DIMENSIONS AND CONCRETE QUANTITIES MAY VARY BASED ON THE FINAL GRADED SLOPE, PIPE SKEW, AND/OR TYPE OF PIPE.
  - WOVEN WIRE REINFORCEMENT (WWF 6"x6" - W2.9xW2.9) IS REQUIRED FOR THE SLOPE PAVING AND TOE WALL. UTILIZE 2" CLEARANCE FROM ALL EDGES.
  - DIMENSIONS AND CONCRETE QUANTITIES SHOWN ARE FOR ONE (1) HEADWALL, INSTALLED ON A PIPE WITH SKEW = 0°.
  - AFTER THE PIPE HAS BEEN MITERED, ANCHOR THE PIPE TO THE CONCRETE SLOPE PAVING BY CORE DRILLING AND INSTALLING 1/2" DIAMETER x 7" LENGTH STEEL WEDGE ANCHORS (3" MINIMUM EMBEDMENT) ON 18" CENTERS ALONG THE SIDES OF THE PIPE. HOLE SIZE & DEPTH, TORQUE, & INSTALLATION PROCEDURES PER RECOMMENDATION OF ANCHOR MANUFACTURER. NOTE: STEEL WEDGE ANCHORS ARE NOT REQUIRED FOR REINFORCED CONCRETE PIPE.
  - THE FOLLOWING SITUATIONS REQUIRE A HEADWALL WITH A GRATE:
    - 24" DIAMETER PIPE ON GREATER THAN 30° SKEW
    - 30" DIAMETER PIPE ON GREATER THAN 15° SKEW
    - PIPE WITH GREATER THAN 30" DIAMETER.
    - ELLIPTICAL PIPE GREATER THAN 24" EQUIVALENT DIAMETER
 SEE SHEET 2 FOR GRATE DETAILS.
  - ALL BOLTS AND HARDWARE SHALL BE RUST RESISTANT: ZINC PLATED, STAINLESS STEEL, OR STEEL THAT HAS BEEN GALVANIZED IN ACCORDANCE WITH AASHTO M 232.

NOT TO SCALE

DEPARTMENT OF HIGHWAYS
KENTUCKY
SLOPED & MITERED CONCRETE HEADWALL (SHEET 1 OF 2)

SEE SHEET 2 FOR DIMENSIONS OF HEADWALLS FOR PIPE OVER 30" DIAMETER

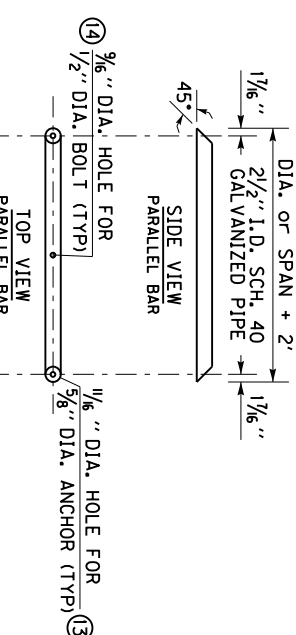
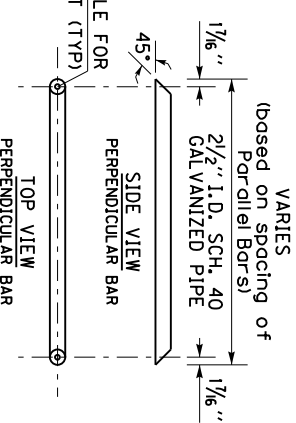
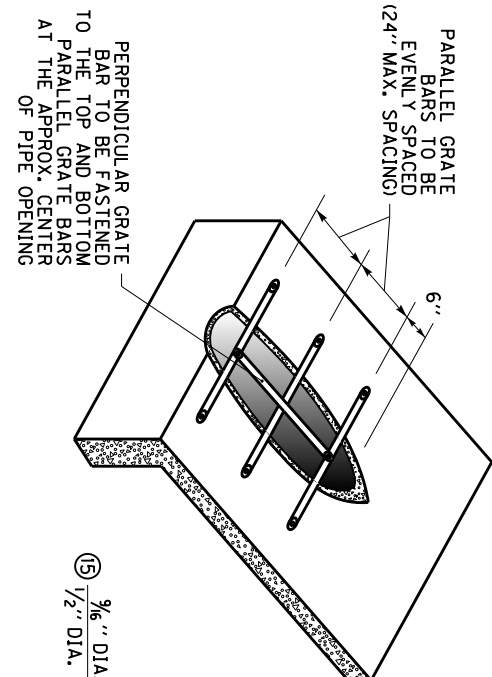
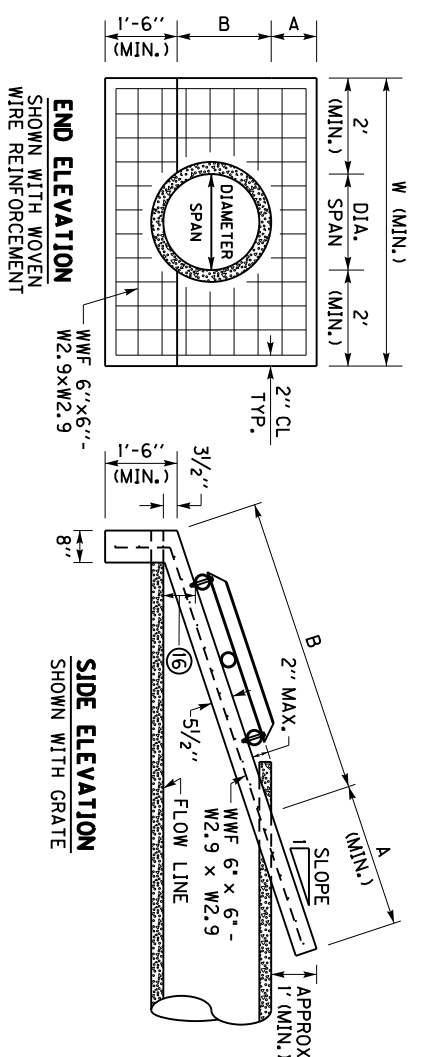

- ~ NOTES ~
- SEE SHEET 1 FOR NOTES 1 THRU 8
  - THE FOLLOWING SITUATIONS REQUIRE A HEADWALL WITH A GRATE:
    - 24\"/>
  - 30\"/>
  - PIPE WITH GREATER THAN 30\"/>
  - ELLIPTICAL PIPE GREATER THAN 24\"/>
  - ALL BOLTS AND HARDWARE SHALL BE RUST RESISTANT; ZINC PLATED, STAINLESS STEEL, OR STEEL THAT HAS BEEN GALVANIZED IN ACCORDANCE WITH AASHTO M 232.
  - THE PIPE USED TO CONSTRUCT THE GRATE SHALL BE STEEL, SCHEDULE 40, CONFORMING TO ASTM A53, AND GALVANIZED IN ACCORDANCE WITH AASHTO M 111 AFTER FABRICATION.
  - ANY RAW METAL EXPOSED BY FIELD CUTTING AND/OR DRILLING SHALL BE TREATED WITH A COLD GALVANIZING COMPOUND.
  - FASTEN PARALLEL BARS TO HEADWALL WITH 5/8\"/>
  - LENGTH STEEL WEDGE ANCHORS, MINIMUM EMBEDMENT = 24\"/>
  - HOLE SIZE AND DEPTH, TORQUE, & INSTALLATION PROCEDURES PER RECOMMENDATION OF ANCHOR MANUFACTURE.
  - CENTER BOLT HOLE SHALL ONLY BE DRILLED IN THE TOP AND BOTTOM PARALLEL BARS.
  - FASTEN THE PERPENDICULAR BAR TO THE TOP AND BOTTOM PARALLEL BARS WITH 1/2\"/>
  - THE BOTTOM PARALLEL BAR IS TO BE PLACED SO THAT IT IS APPROX. 6\"/>

**PIPE FOR GRATE DETAILS**  
SEE NOTE 9 TO DETERMINE  
IF GRATE IS REQUIRED

DIMENSIONS AND CONCRETE QUANTITIES (FOR PIPE WITH SKEW = 0°) ④

PIPE SIZE	3:1 SLOPE			4:1 SLOPE			6:1 SLOPE			GRATE REQUIRED	
	A	B	W	A	B	W	A	B	W		
36"	3'	9'-7 1/2"	7'-0"	4'	12'-6 1/2"	7'-0"	6'	18'-6"	7'-0"	2.42	YES
42"	3'	11'-4"	7'-6"	4'	14'-9 1/4"	7'-6"	6'	21'-9 1/2"	7'-6"	3.19	YES

••DIMENSIONS AND CONCRETE QUANTITIES ARE APPROXIMATE AND LISTED FOR INFORMATIONAL PURPOSES ONLY••

**BID ITEM AND UNIT TO BID: 24575ES610 HEADWALL (SLOPED & MITERED CONCRETE-FOR 3\"/>**

SEE SHEET 1 FOR  
DIMENSIONS OF  
HEADWALLS FOR PIPE  
30\"/>

NOT TO SCALE

KENTUCKY
DEPARTMENT OF HIGHWAYS
SLOPED & MITERED CONCRETE HEADWALL (SHEET 2 OF 2)

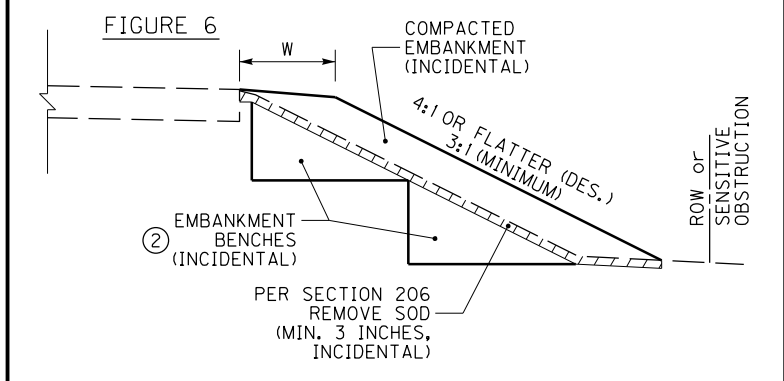
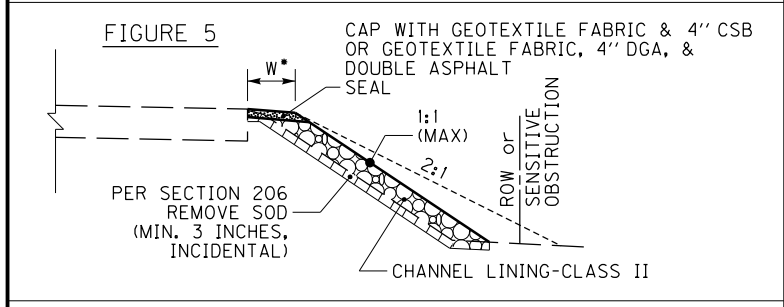
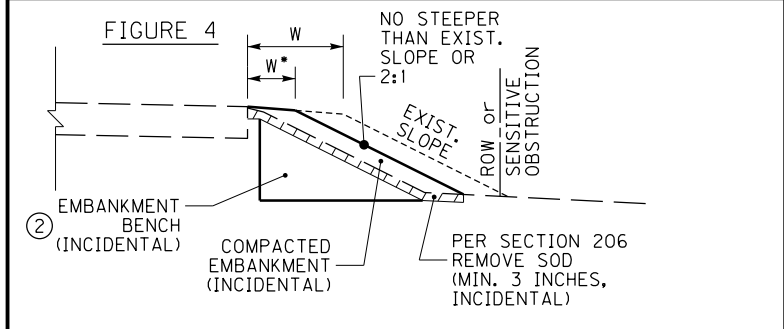
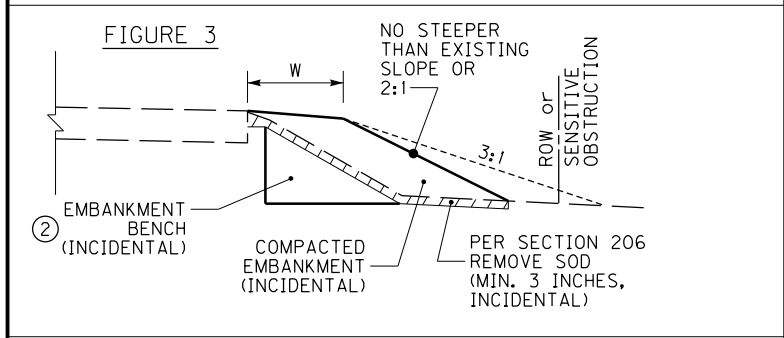
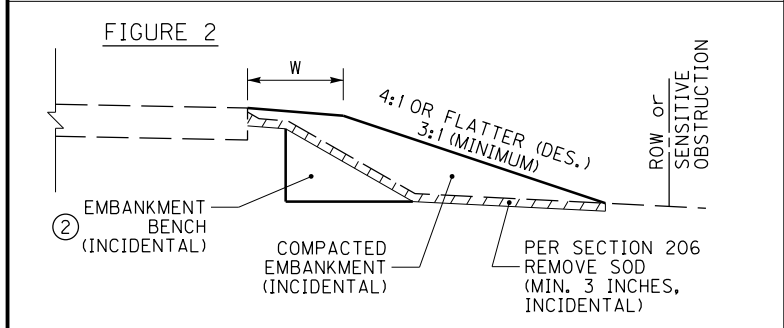
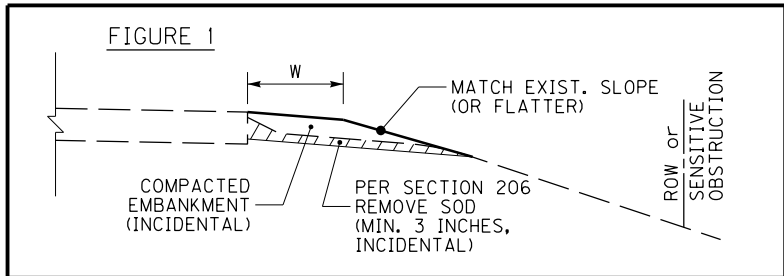

~ NOTES ~

BID ITEM AND UNIT TO BID:  
2575 - DITCHING & SHOULDERING - LF

- THE BID ITEM 'DITCHING & SHOULDERING' SHALL CONSIST OF ANY AND ALL NECESSARY CLEARING & GRUBBING, GRADING, AND/OR RESHAPING OF THE EXISTING SHOULDER, DITCH, AND/OR ROADSIDE TO ACHIEVE THE PROPOSED SHOULDER, DITCH, AND/OR ROADSIDE DIMENSIONS, AS DETAILED ON THE TYPICAL SECTIONS. FINAL PAYMENT WILL BE BASED ON THE ACTUAL LINEAR FEET OF DITCHING AND SHOULDERING PERFORMED, AND WILL INCLUDE ALL WORK AND INCIDENTALS NECESSARY TO PERFORM THE DITCHING AND SHOULDERING ACCORDING TO THESE DETAILS, NOTES, AND ANY OTHER INFORMATION FOUND ELSEWHERE IN THE PROPOSAL OR STANDARD SPECIFICATIONS. IN THE CASE OF A DISCREPANCY, REFER TO SECTION 105.05 OF THE STANDARD SPECIFICATIONS. DEPENDING ON THE EXISTING CONDITIONS ENCOUNTERED, DITCHING AND SHOULDERING MAY ALSO INCLUDE, BUT IS NOT LIMITED TO:
  - PROVIDING ADDITIONAL EARTH MATERIAL AND GRADING, SHAPING, AND COMPACTING THE EARTH MATERIAL TO ACHIEVE THE DIMENSIONS SHOWN ON THE TYPICAL SECTIONS. COMPACT MATERIAL ACCORDING TO SECTION 206 OF THE STANDARD SPECIFICATIONS.
  - NOTE: ADDITIONAL EARTH MATERIAL PROVIDED SHALL BE SUITABLE FOR VEGETATION GROWTH.
  - EXCAVATING AND REMOVING EXCESS MATERIAL TO ACHIEVE THE DIMENSIONS SHOWN ON THE TYPICAL SECTIONS
  - EMBANKMENT BENCHING
- EMBANKMENT BENCHING WILL BE REQUIRED WHEN THE EXISTING GROUNDLINE HAS AN INCLINE GREATER THAN 15% (APPROX. 6:1). ANY AND ALL REQUIRED EMBANKMENT BENCHING SHALL BE INCIDENTAL TO THE BID ITEM 'DITCHING AND SHOULDERING'. THE FOLLOWING ARE GUIDELINES FOR EMBANKMENT BENCHING USED IN CONJUNCTION WITH THE BID ITEM 'DITCHING AND SHOULDERING':
  - THE TYPICAL HEIGHT (OR RISE) IS 1' TO 6'
  - THE TYPICAL WIDTH (OR RUN) WILL VARY BASED ON THE HEIGHT OF THE BENCH
  - MULTIPLE SMALL BENCHES MAY BE USED, AND MAY BE MORE ADVANTAGEOUS AS THIS WILL REQUIRE PROCESSING LESS EARTHWORK.
- AS SHOWN IN FIGURE 1, IN SOME SITUATIONS, MINOR SHOULDERING, WITH MINIMAL ADDITIONAL EARTH MATERIAL, MAY BE ALL THAT IS REQUIRED TO RESHAPE THE EARTH SHOULDER TO THE PROPOSED WIDTH AND BRING IT FLUSH WITH THE EDGE OF PAVEMENT.
- AS SHOWN IN FIGURE 2, MOST SITUATIONS WILL REQUIRE ADDITIONAL EARTH MATERIAL TO ACHIEVE THE PROPOSED EARTH SHOULDER WIDTH. IT IS DESIRED THAT THE RESULTING FILL SLOPE BE INSTALLED AS FLAT AS POSSIBLE AND REMAIN WITHIN THE RIGHT-OF-WAY AND/OR AVOID SENSITIVE OBSTRUCTIONS.
- AS SHOWN IN FIGURE 3, IF A 3:1 FILL SLOPE WILL RESULT IN THE TOE OF SLOPE EXTENDING BEYOND THE RIGHT-OF-WAY OR IMPACT A SENSITIVE OBSTRUCTION, THEN THE FILL SLOPE MAY BE INSTALLED STEEPER THAN 3:1, BUT NO STEEPER THAN THE EXISTING FILL SLOPE, OR A 2:1, WHICHEVER IS FLATTER.
- AS SHOWN IN FIGURE 4, IF MATCHING THE EXISTING FILL SLOPE OR INSTALLING A 2:1 FILL SLOPE (WHICHEVER IS FLATTER) STILL RESULTS IN THE TOE OF SLOPE EXTENDING BEYOND THE RIGHT-OF-WAY OR STILL IMPACTS A SENSITIVE OBSTRUCTION, THEN THE PROPOSED EARTH SHOULDER WIDTH MAY BE REDUCED SO THAT THE RESULTING TOE OF SLOPE WILL REMAIN WITHIN THE RIGHT-OF-WAY AND/OR NOT IMPACT THE SENSITIVE OBSTRUCTION.
- AS SHOWN IN FIGURE 5, IF THE EXISTING FILL SLOPE IS STEEPER THAN 2:1 AND THERE IS NOT ENOUGH SPACE TO INSTALL A 2:1 FILL SLOPE WITHOUT EXTENDING BEYOND THE RIGHT-OF-WAY AND/OR IMPACTING A SENSITIVE OBSTRUCTION, THEN CLASS II CHANNEL LINING MAY BE INSTALLED ALONG THE STEEP EXISTING SLOPE IN ORDER TO ESTABLISH A WIDTH OF AGGREGATE SHOULDER. THESE LOCATIONS WILL BE NOTED ELSEWHERE IN THE PROPOSAL AS SLOPE PROTECTION. THE CHANNEL LINING IS TO BE CAPPED WITH GEOTEXTILE FABRIC TYPE IV AND 4" OF CRUSHED STONE BASE, OR 4" OF DGA WITH DOUBLE ASPHALT SEAL COAT.
- AS SHOWN IN FIGURE 6, AS THE HEIGHT OF THE FILL INCREASES, MULTIPLE EMBANKMENT BENCHES MAY BE REQUIRED.

SEE SHEET 2 FOR NOTES 9 THRU 13

<b>KENTUCKY</b>
<b>DEPARTMENT OF HIGHWAYS</b>
DITCHING & SHOULDERING AND EMBANKMENT BENCHING DETAILS (SHEET 1 OF 2)

NOT TO SCALE

FIGURE 7

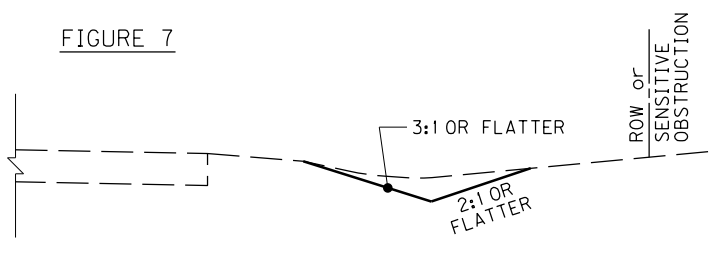

FIGURE 8

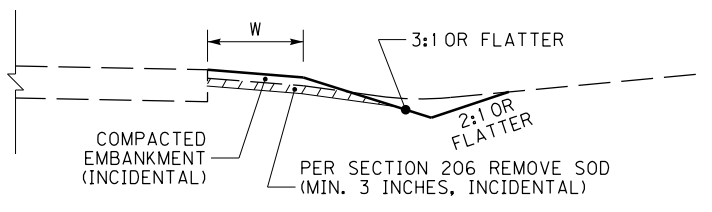

FIGURE 9

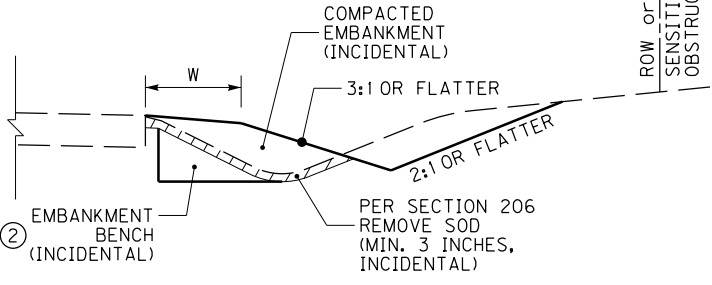

FIGURE 10

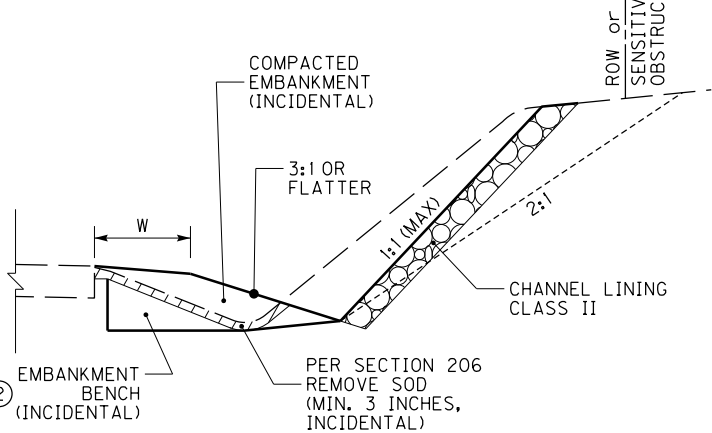
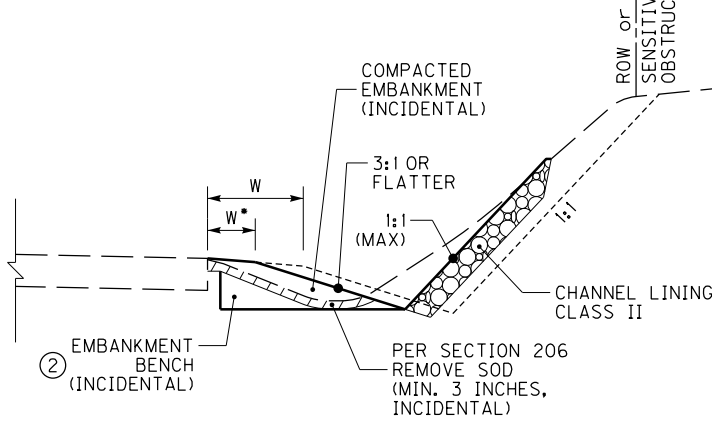

FIGURE 11



~ NOTES ~

BID ITEM AND UNIT TO BID:  
2575 - DITCHING & SHOULDERING - LF

1. THE BID ITEM 'DITCHING & SHOULDERING' SHALL CONSIST OF ANY AND ALL NECESSARY CLEARING & GRUBBING, GRADING, AND/OR RESHAPING OF THE EXISTING SHOULDER, DITCH, AND/OR ROADSIDE TO ACHIEVE THE PROPOSED SHOULDER, DITCH, AND/OR ROADSIDE DIMENSIONS, AS DETAILED ON THE TYPICAL SECTIONS. FINAL PAYMENT WILL BE BASED ON THE ACTUAL LINEAR FEET OF DITCHING AND SHOULDERING PERFORMED, AND WILL INCLUDE ALL WORK AND INCIDENTALS NECESSARY TO PERFORM THE DITCHING AND SHOULDERING ACCORDING TO THESE DETAILS, NOTES, AND ANY OTHER INFORMATION FOUND ELSEWHERE IN THE PROPOSAL OR STANDARD SPECIFICATIONS. IN THE CASE OF A DISCREPANCY, REFER TO SECTION 105.05 OF THE STANDARD SPECIFICATIONS. DEPENDING ON THE EXISTING CONDITIONS ENCOUNTERED, DITCHING AND SHOULDERING MAY ALSO INCLUDE, BUT IS NOT LIMITED TO:

- PROVIDING ADDITIONAL EARTH MATERIAL AND GRADING, SHAPING, AND COMPACTING THE EARTH MATERIAL TO ACHIEVE THE DIMENSIONS SHOWN ON THE TYPICAL SECTIONS. COMPACT MATERIAL ACCORDING TO SECTION 206 OF THE STANDARD SPECIFICATIONS.
- NOTE: ADDITIONAL EARTH MATERIAL PROVIDED SHALL BE SUITABLE FOR VEGETATION GROWTH.
- EXCAVATING AND REMOVING EXCESS MATERIAL TO ACHIEVE THE DIMENSIONS SHOWN ON THE TYPICAL SECTIONS
- EMBANKMENT BENCHING

② EMBANKMENT BENCHING WILL BE REQUIRED WHEN THE EXISTING GROUNDLINE HAS AN INCLINE GREATER THAN 15% (APPROX. 6:1). ANY AND ALL REQUIRED EMBANKMENT BENCHING SHALL BE INCIDENTAL TO THE BID ITEM 'DITCHING AND SHOULDERING'. THE FOLLOWING ARE GUIDELINES FOR EMBANKMENT BENCHING USED IN CONJUNCTION WITH THE BID ITEM 'DITCHING AND SHOULDERING':

- THE TYPICAL HEIGHT (OR RISE) IS 1' TO 6'
- THE TYPICAL WIDTH (OR RUN) WILL VARY BASED ON THE HEIGHT OF THE BENCH
- MULTIPLE SMALL BENCHES MAY BE USED, AND MAY BE MORE ADVANTAGEOUS AS THIS WILL REQUIRE PROCESSING LESS EARTHWORK.

SEE SHEET 1 FOR NOTES 3. THRU 8.

9. AS SHOWN IN FIGURE 7, IN SOME SITUATIONS, ALL THAT MAY BE REQUIRED IS TO CLEAN OUT THE EXISTING DITCH AND RESHAPE IT TO THE PROPOSED DIMENSIONS. THE MATERIAL EXCAVATED FROM THE DITCH MAY BE RE-USED ELSEWHERE ON THE PROJECT, PROVIDED THE ENGINEER DETERMINES THE MATERIAL REMOVED FROM THE DITCH IS SUITABLE FOR THE INTENDED RE-USE.
10. AS SHOWN IN FIGURE 8, IN SOME SITUATIONS, THE DITCH AND SHOULDER MAY ONLY NEED MINOR REGRADING AND/OR RESHAPING. THE MATERIAL EXCAVATED FROM THE DITCH MAY BE USED TO RESHAPE THE EARTH SHOULDER, PROVIDED THE ENGINEER DETERMINES THE MATERIAL REMOVED FROM THE DITCH IS SUITABLE FOR SHOULDERING. IF THE MATERIAL IS NOT SUITABLE, ADDITIONAL EARTH MATERIAL MAY BE REQUIRED.
11. AS SHOWN IN FIGURE 9, IN MOST SITUATIONS, REGRADING AND RESHAPING THE ROADSIDE TO ACHIEVE THE PROPOSED SHOULDER, DITCH, AND/OR ROADSIDE DIMENSIONS WILL RESULT IN MOVING THE DITCH FURTHER AWAY FROM THE ROADWAY. IT IS DESIRED THAT DITCH FORESLOPES BE 3:1 OR FLATTER AND DITCH BACKSLOPES BE 2:1 OR FLATTER.
12. AS SHOWN IN FIGURE 10, IF INSTALLING A 2:1 DITCH BACKSLOPE WILL RESULT IN THE TOP OF CUT EXTENDING BEYOND THE RIGHT-OF-WAY OR IMPACTING A SENSITIVE OBSTRUCTION, THEN THE DITCH BACK SLOPE MAY BE INSTALLED STEEPER THAN 2:1, UP TO 1:1 MAXIMUM. IN THIS SITUATION, THE DITCH BACKSLOPE SHALL HAVE CLASS II CHANNEL LINING INSTALLED FOR SLOPE PROTECTION.
13. AS SHOWN IN FIGURE 11, IF USING A 1:1 DITCH BACKSLOPE STILL RESULTS IN THE TOP OF CUT EXTENDING BEYOND THE RIGHT-OF-WAY OR STILL IMPACTS A SENSITIVE OBSTRUCTION, THEN THE PROPOSED EARTH SHOULDER WIDTH MAY BE REDUCED SO THAT THE STEEP DITCH BACKSLOPE CAN BE INSTALLED WITHIN THE RIGHT-OF-WAY AND/OR TO AVOID A SENSITIVE OBSTRUCTION.

**KENTUCKY  
DEPARTMENT OF HIGHWAYS**

DITCHING & SHOULDERING  
AND EMBANKMENT  
BENCHING DETAILS  
(SHEET 2 OF 2)

NOT TO SCALE

COUNTY OF	ITEM NO.	SHEET NO.

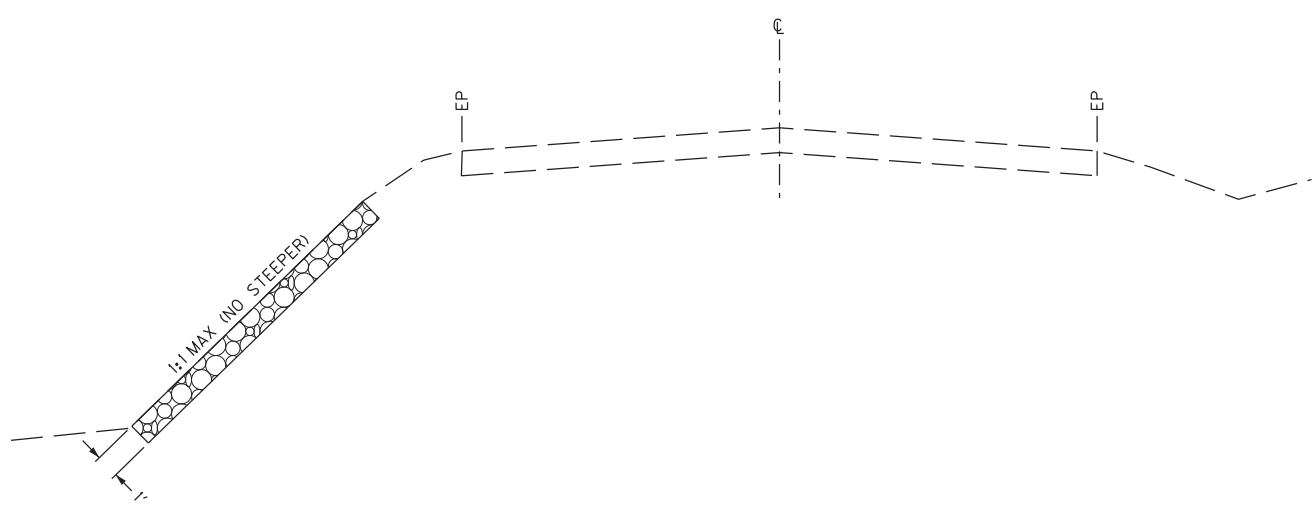

**PROTECTION DETAIL FOR EMBANKMENT FILL SLOPE**

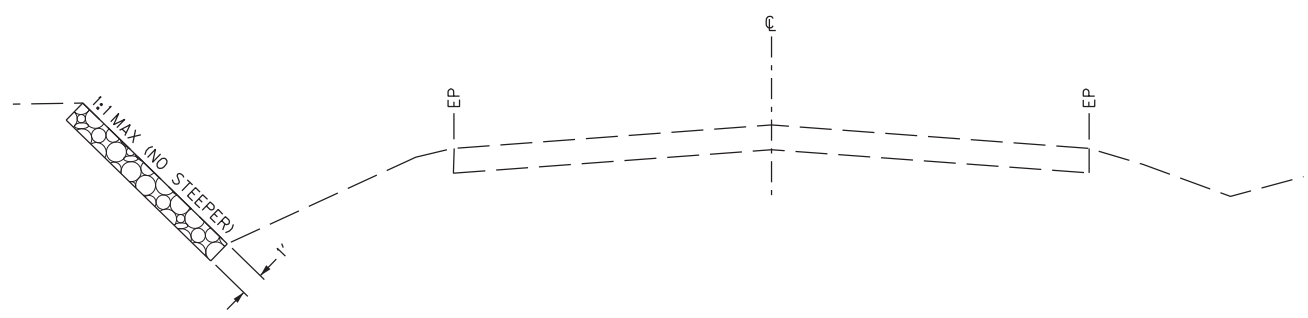

**PROTECTION DETAIL FOR DITCH BACKSLOPE**

NOTES:

1. SEE CHANNEL LINING SUMMARY FOR APPROXIMATE LOCATIONS OF SLOPE PROTECTION.
2. FINAL LOCATIONS TO BE DETERMINED BY THE ENGINEER.
3. EXCAVATION IS INCIDENTAL TO THE PLACEMENT OF THE CHANNEL LINING.

SLOPE PROTECTION DETAILS



COUNTY OF	ITEM NO.	SHEET NO.

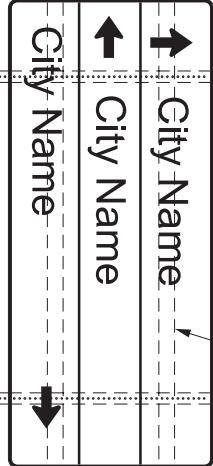

SEE SHEETING SIGN DETAIL SHEET 2 OF 2 FOR BRACING REQUIREMENTS

NOTE: SEE SIGN DETAIL SHEETS FOR QUANTITY, LENGTH, SIZE AND GAUGE OF TYPE I POSTS

PLAN VIEW  
NOT TO SCALE

PLAN VIEW  
NOT TO SCALE

PLAN VIEW  
NOT TO SCALE

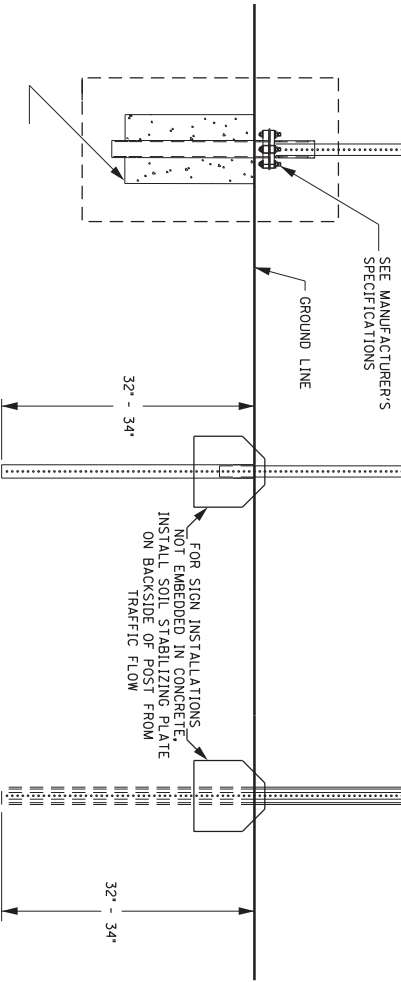

TYPE J  
SQUARE TUBING POST WITH TYPE "D" SUPPORT

TYPE J  
SQUARE TUBING POST WITH SOIL STABILIZER

TYPE II  
CHANNEL POST WITH SOIL STABILIZER

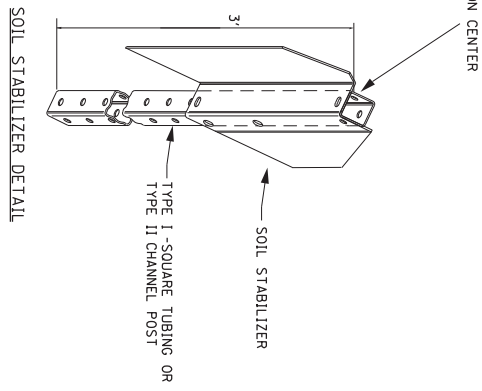

SOIL STABILIZER DETAIL

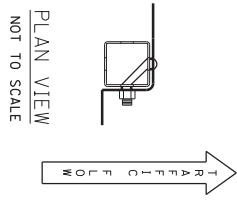

PLAN VIEW  
NOT TO SCALE

ADDED HOLE IN SOIL PLATE  
STRAIGHT 3/8"-16 x 3"  
GRADE 5 HEX CAP SCREW,  
NUT, & TWO WASHERS

SOIL STABILIZER DETAIL  
FOR TYPE I POST

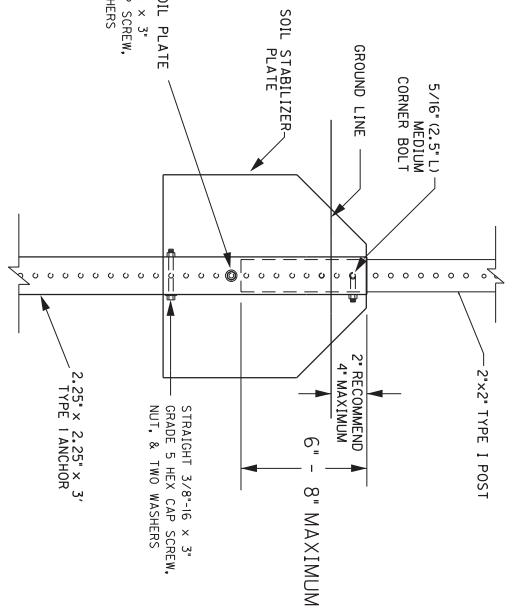

NOT TO SCALE

SHEETING SIGN DETAIL  
SHEET 1 OF 2

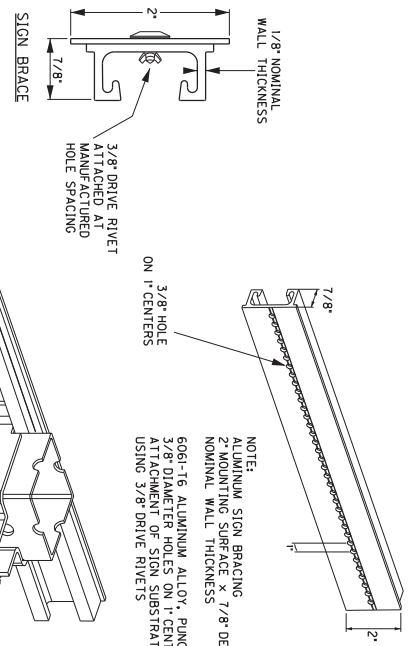

FOR ATTACHMENT OF SIGNS LESS THAN 72" IN WIDTH USING MANUFACTURED 3/8" HOLES ACCORDING TO 2004 STANDARD HIGHWAY SIGNS BLANK STANDARDS POST 7-1 THRU 7-6

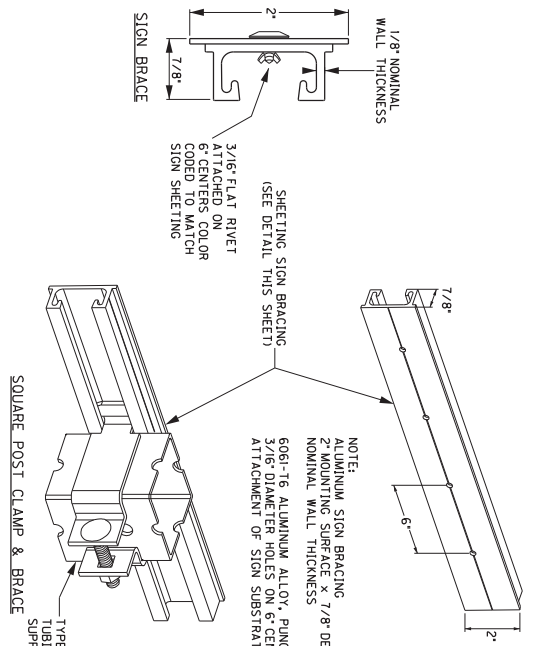

FOR ATTACHMENT OF SIGNS GREATER THAN, OR EQUAL TO, 72" IN WIDTH, RIVETS SHALL BE COLOR CODED TO MATCH SHEETING IN ORDER TO MINIMIZE GLARE FROM RIVETS

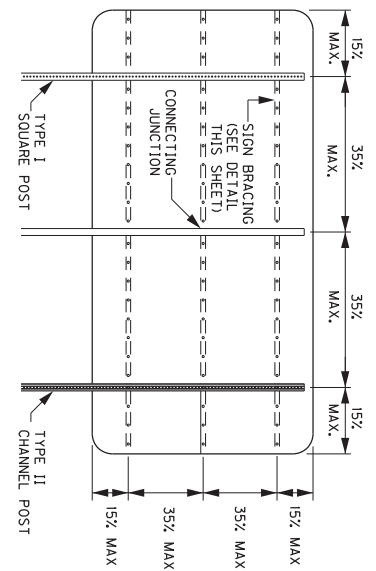

3 POST - BRACING DIAGRAM  
NOTE:  
1. MAXIMUM AREA PER CONNECTING JUNCTION = 16 SQ. FT.  
2. BRACING SHOULD NOT BE SPLICED WITHIN 6" OF A BRACE TO POST JUNCTION.

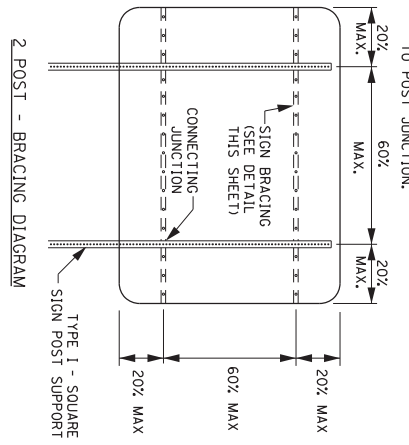

2 POST - BRACING DIAGRAM  
NOTE:  
USE OF SIGN BRACING NOT SHOWN ON THIS SHEET MAY BE PERMITTED BY PROJECT ENGINEER AND/OR DISTRICT TRAFFIC ENGINEER.

COUNTY OF	ITEM NO.	SHEET NO.

NOT TO SCALE  
SHEETING SIGN DETAIL  
SHEET 2 OF 2

COUNTY OF	ITEM NO.	SHEET NO.

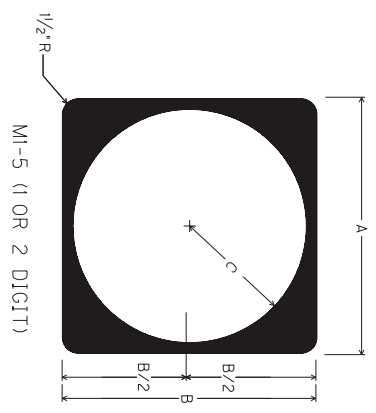
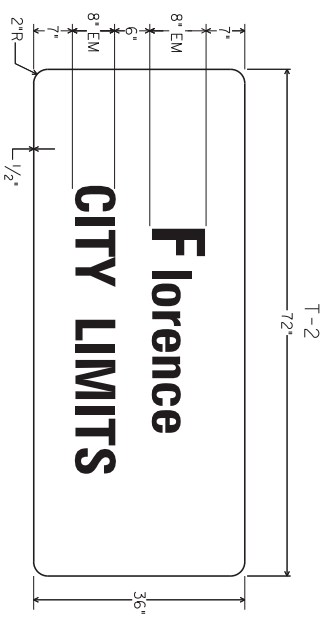
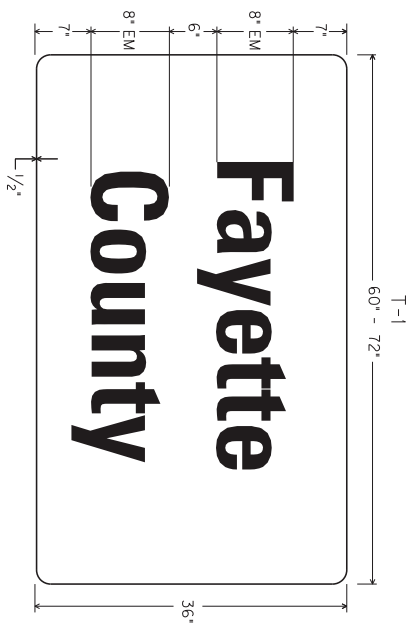

	A	B	C	FONT
CONVENTIONAL	24"	24"	11"	12D
EXPRESSWAY/ FREEWAY	36"	36"	17"	18D

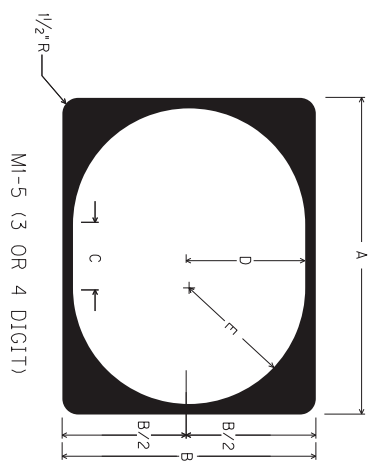

	A	B	C	D	E	FONT	
						3 DIGIT	4 DIGIT
CONVENTIONAL	30"	24"	6"	11"	11"	12D	12B
EXPRESSWAY/ FREEWAY	45"	36"	9"	16.5"	16.5"	18D	18B

NOTE: FOR ROUTE MARKERS, IF NECESSARY, ADJUSTMENTS TO THE DIGIT LAYOUT AND/OR FONT TYPE MAY BE MADE TO ENSURE VISUAL ACUITY

NOTE: EXPRESSWAY/FREEWAY DEFINED AS A DIVIDED HIGHWAY WITH PARTIAL OR FULL CONTROL OF ACCESS

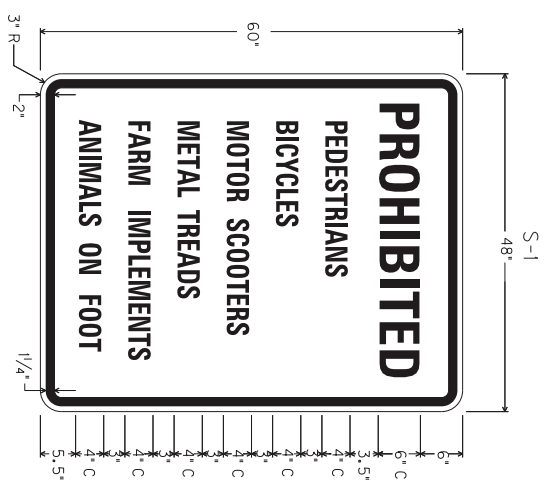

NOT TO SCALE

TYPICAL SIGNS

# GUARDRAIL DELIVERY VERIFICATION SHEET

Contract Id: \_\_\_\_\_

Contractor: \_\_\_\_\_

Section Engineer: \_\_\_\_\_

District & County: \_\_\_\_\_

<u>DESCRIPTION</u>	<u>UNIT</u>	<u>QTY LEAVING PROJECT</u>	<u>QTY RECEIVED@BB YARD</u>
GUARDRAIL (Includes End treatments & crash cushions)	LF	_____	_____
STEEL POSTS	EACH	_____	_____
STEEL BLOCKS	EACH	_____	_____
WOOD OFFSET BLOCKS	EACH	_____	_____
BACK UP PLATES	EACH	_____	_____
CRASH CUSHION	EACH	_____	_____
NUTS, BOLTS, WASHERS	BAG/BCKT	_____	_____
DAMAGED RAIL TO MAINT. FACILITY	LF	_____	_____
DAMAGED POSTS TO MAINT. FACILITY	EACH	_____	_____

**\*Required Signatures before Leaving Project Site**

Printed Section Engineer's Representative \_\_\_\_\_ & Date \_\_\_\_\_

Signature Section Engineer's Representative \_\_\_\_\_ & Date \_\_\_\_\_

Printed Contractor's Representative \_\_\_\_\_ & Date \_\_\_\_\_

Signature Contractor's Representative \_\_\_\_\_ & Date \_\_\_\_\_

**\*Required Signatures after Arrival at Bailey Bridge Yard (All material on truck must be counted & the quantity received column completed before signatures)**

Printed Bailey Bridge Yard Representative \_\_\_\_\_ & Date \_\_\_\_\_

Signature Bailey Bridge Yard Representative \_\_\_\_\_ & Date \_\_\_\_\_

Printed Contractor's Representative \_\_\_\_\_ & Date \_\_\_\_\_

Signature Contractor's Representative \_\_\_\_\_ & Date \_\_\_\_\_

\*\*Payment for the bid item remove guardrail will be based upon the quantities shown in the Bailey Bridge Yard received column. Payment will not be made for guardrail removal until the guardrail verification sheets are electronically submitted to the Section Engineer by the Bailey Bridge Yard Representative.

Completed Form Submitted to Section Engineer Date: \_\_\_\_\_ By: \_\_\_\_\_

### BRIDGE DETAIL FOR PAVING PROJECT

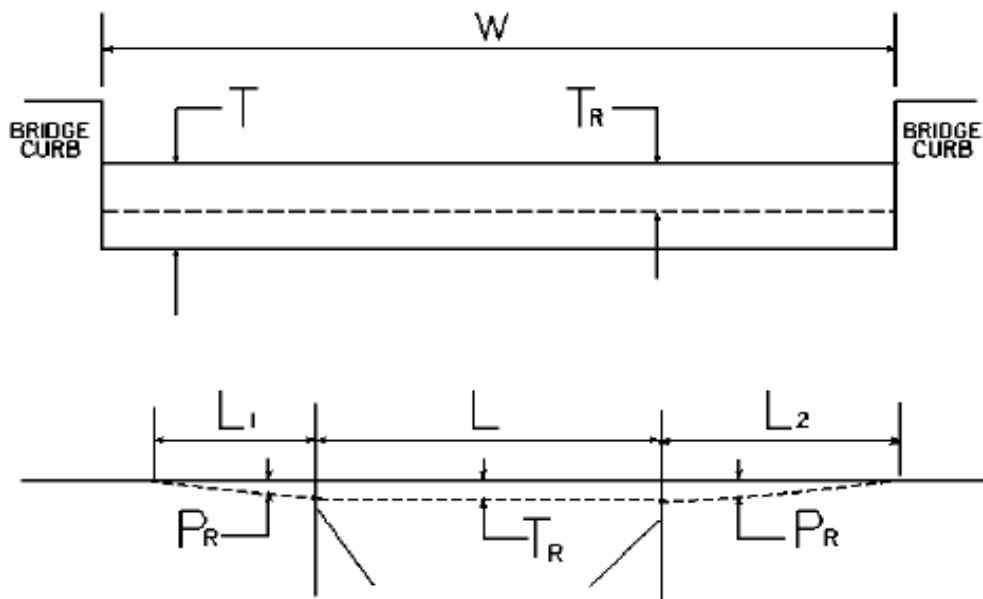

W = bridge width curb to curb

T = thickness of existing asphalt overlay

L = length of bridge

L<sub>1</sub> & L<sub>2</sub> = length of approach pavement to be removed

T<sub>R</sub> = thickness to be removed and replaced on bridge

P<sub>R</sub> = thickness to be removed and replaced on pavement

Note: L<sub>1</sub> & L<sub>2</sub> lengths shall be determined by using a transition rate of 100 ft/in of thickness

Route	Bridge No.	MP	W (ft)	T (in)	L <sub>1</sub> (ft)	L <sub>2</sub> (ft)	T <sub>R</sub> (in)	L (ft)	P <sub>R</sub> (in)
KY 130	B00001N	12.537	23.00	1.00	100.00	100.00	1.00	50.00	1.00
KY 130	B00002N	13.478	23.00	0.00	100.00	100.00	0.00	115.00	1.00

**PART II**  
**SPECIFICATIONS AND STANDARD DRAWINGS**

### **SPECIFICATIONS REFERENCE**

Any reference in the plans or proposal to previous editions of the *Standard Specifications for Road and Bridge Construction* and *Standard Drawings* are superseded by *Standard Specifications for Road and Bridge Construction, Edition of 2019* and *Standard Drawings, Edition of 2020*.

## **SUPPLEMENTAL SPECIFICATIONS**

The contractor shall use the Supplemental Specifications that are effective at the time of letting.  
The Supplemental Specifications can be found at the following link:

<http://transportation.ky.gov/Construction/Pages/Kentucky-Standard-Specifications.aspx>

### SPECIAL NOTE FOR BARCODE LABEL ON PERMANENT SIGNS

**1.0 DESCRIPTION.** Install barcode label on sheeting signs. Section references herein are to the Department’s Standard Specifications for Road and Bridge Construction, current edition.

**2.0 MATERIALS.** The Department will provide the Contractor with a 2 inch x 1 inch foil barcode label for each permanent sheeting sign. A unique number will be assigned to each barcode label.

The Contractor shall contact the Operations and Pavement Management Branch in the Division of Maintenance at (502) 564-4556 to obtain the barcode labels.

**3.0 CONSTRUCTION.** Apply foil barcode label in the lower right quadrant of the sign back. Signs where the bottom edge is not parallel to the ground, the lowest corner of the sign shall serve as the location to place the barcode label. The barcode label shall be placed no less than one-inch and no more than three inches from any edge of the sign. The barcode must be placed so that the sign post does not cover the barcode label.

Barcodes shall be applied in an indoor setting with a minimum air temperature of 50°F or higher. Prior to application of the barcode label, the back of the sign must be clean and free of dust, oil, etc. If the sign is not clean, an alcohol swab shall be used to clean the area. The area must be allowed to dry prior to placement of the barcode label.

Data for each sign shall include the barcode number, MUTCD reference number, sheeting manufacturer, sheeting type, manufacture date, color of primary reflective surface, installation date, latitude and longitude using the North American Datum of 1983 (NAD83) or the State Plane Coordinates using an x and y ordinate of the installed location.

Data should be provided electronically on the TC 71-229 Sign Details Information and TC 71-230 Sign Assembly Information forms. The Contractor may choose to present the data in a different format provided that the information submitted to the Department is equivalent to the information required on the Department TC forms. The forms must be submitted in electronic format regardless of which type of form is used. The Department will not accept PDF or handwritten forms. These completed forms must be submitted to the Department prior to final inspection of the signs. The Department will not issue formal acceptance for the project until the TC 71-229 and TC-230 electronic forms are completed for all signs and sign assemblies on the project.

**4.0 MEASUREMENT.** The Department will measure all work required for the installation of the barcode label and all work associated with completion and submission of the sign inventory data (TC 71-229 and TC 71-230).

The installation of the permanent sign will be measured in accordance to Section 715.

**5.0 PAYMENT.** The Department will make payment for the completed and accepted quantities under the following:

<u>Code</u>	<u>Pay Item</u>	<u>Pay Unit</u>
24631EC	Barcode Sign Inventory	Each

The Department will not make payment for this item until all barcodes are installed and sign inventory is complete on every permanent sign installed on the project. The Department will make payment for installation of the permanent sign in accordance to Section 715. The Department will consider payment as full compensation for all work required under this special note.

### One Sign Post



↑  
2" Wide Post

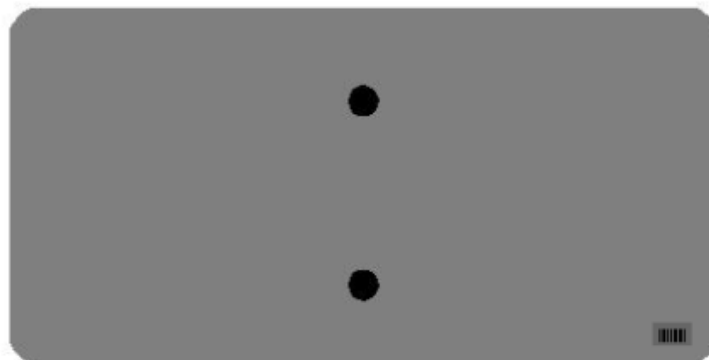
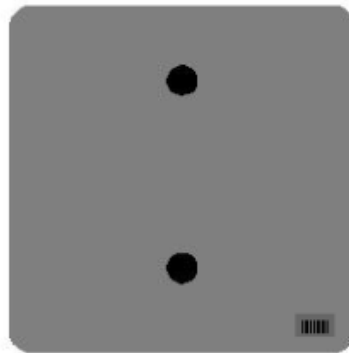

### One Sign Post

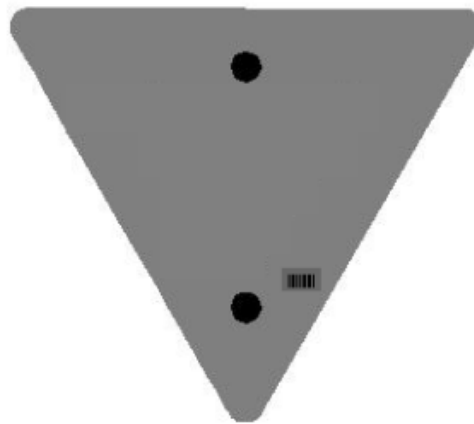
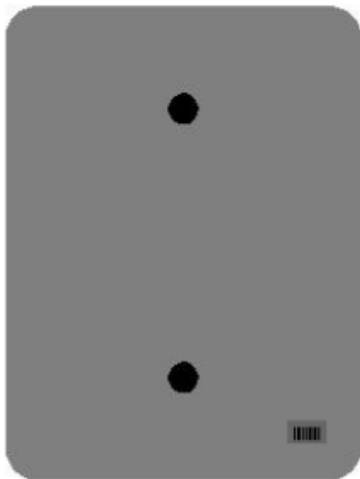
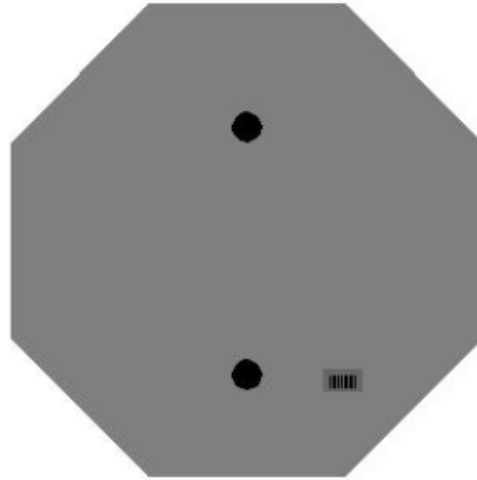
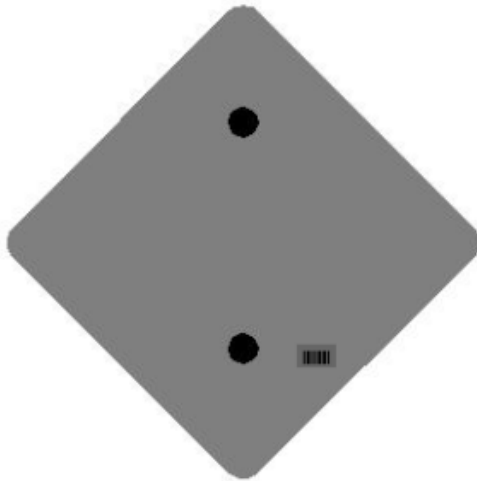

### One Sign Post

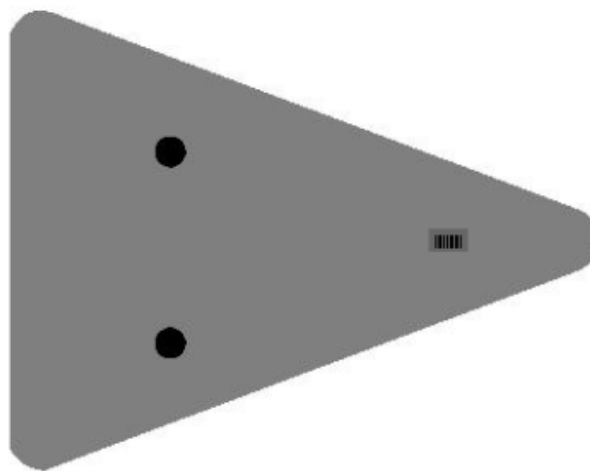
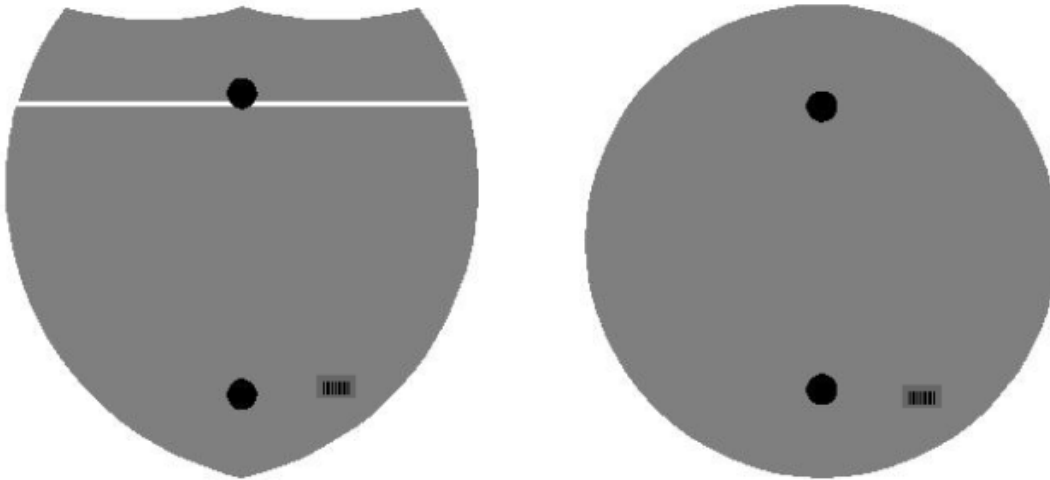

### Double Sign Post

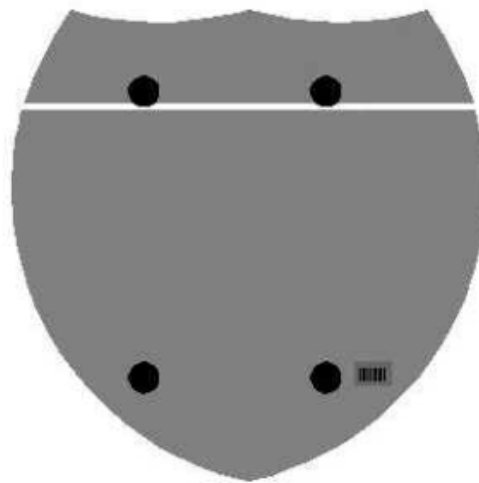

Interstate  
Shield

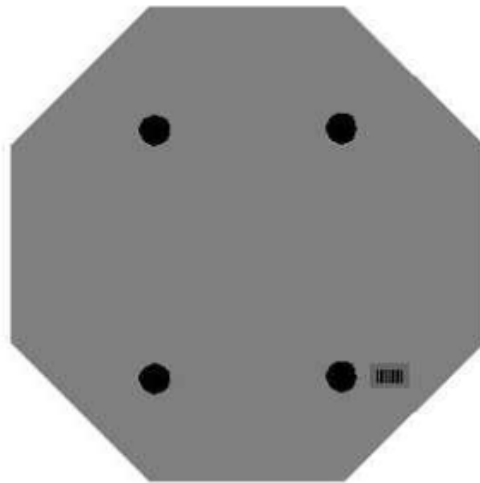

48" Stop

### 2 Post Signs



↑  
2" Wide Post

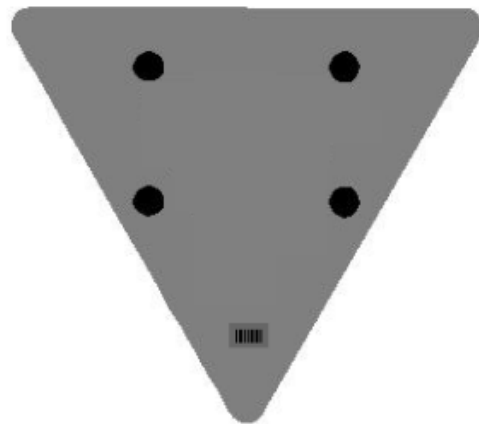

**2020 STANDARD DRAWINGS THAT APPLY**

**ROADWAY  
~ BARRIERS ~**

**GUARDRAIL AND BRIDGE END DRAINAGE**

GUARDRAIL TRANSITION FROM NORMAL SHOULDER TO NARROW BRIDGE..... RBB-010-06

**GUARDRAIL CONNECTORS TO BRIDGE ENDS**

GUARDRAIL CONNECTOR TO BRIDGE END TYPE D..... RBC-004-08

GUARDRAIL CONNECTOR TO BRIDGE END TYPE D NOTES.....RBC-004N

**TYPICAL BARRIER INSTALLATIONS**

TYPICAL GUARDRAIL INSTALLATIONS.....RBI-001-12

TYPICAL GUARDRAIL INSTALLATIONS.....RBI-002-07

INSTALLATION OF GUARDRAIL END TREATMENT TYPE 1.....RBI-004-06

**GUARDRAIL HARDWARE**

STEEL BEAM GUARDRAIL (W-BEAM)..... RBR-001-13

GUARDRAIL COMPONENTS..... RBR-005-11

GUARDRAIL TERMINAL SECTIONS ..... RBR-010-06

STEEL GUARDRAIL POSTS..... RBR-015-06

GUARDRAIL END TREATMENT TYPE 1..... RBR-020-07

DELINEATORS FOR GUARDRAIL..... RBR-005-01

**~ DRAINAGE ~**

**PAVED DITCHES, FLUME INLETS AND CHANNEL LININGS**

CHANNEL LINING CLASS II AND III..... RDD-040-05

**PIPE AND BOX CULVERT HEADWALLS**

**12" – 27" - SINGLE LINE PIPE**

CONCRETE HEADWALLS FOR 12" - 27" CIRCULAR PIPE CULVERTS ..... RDH-005-02

**18" – 48" MULTIPLE LINE PIPE**

18" – 24" DOUBLE AND TRIPLE PIPE CULVERT HEADWALLS AT 0° SKEW ..... RDH-500-03

**TYPICAL DRAINAGE INSTALLATIONS**

CULVERT, ENTRANCE & STORM SEWER PIPE TYPES & COVER HEIGHTS (12" – 24" PIPE) .....RDI-001-10

CULVERT, ENTRANCE & STORM SEWER PIPE TYPES & COVER HEIGHTS (27" – 42" PIPE) .....RDI-002-05

PIPE BEDDING FOR CULVERTS, ENTRANCE, AND STORM SEWER PIPE.....RDI-020-10

PIPE BEDDING FOR CULVERTS, ENTRANCE, AND STORM SEWER, REINFORCED CONC. PIPE.....RDI-021-01

PIPE BEDDING, TRENCH CONDITION .....RDI-025-06

PIPE BEDDING, TRENCH CONDITION, REINFORCED CONC. PIPE .....RDI-026-01

COATINGS, LININGS AND PAVINGS FOR NON-STRUCTURAL PLATE PIPE .....RDI-035-02

EROSION CONTROL BLANKET SLOPE INSTALLATION.....RDI-040-01

EROSION CONTROL BLANKET CHANNEL INSTALLATION.....RDI-041-01

**MISCELLANEOUS DRAINAGE**

INTERMEDIATE AND END ANCHORS FOR CIRCULAR PIPE..... RDX-060-04

TEMPORARY SILT FENCE..... RDX-210-03

SILT TRAP - TYPE A ..... RDX-220-05

SILT TRAP - TYPE B..... RDX-225-01

SILT TRAP - TYPE C..... RDX-230-01

Standard Drawings That Apply  
Page 2 of 2

*~ GENERAL ~*

CURVE WIDENING AND SUPERELEVATION

CURVE WIDENING AND SUPERELEVATION TRANSITIONS .....RGS-001-07

**TRAFFIC**

*~ PERMANENT ~*

RUMBLE STRIPS

SHOULDER & EDGELINE RUMBLE STRIPS PLACEMENT DETAILS ..... TPR-115  
EDGELINE RUMBLE STRIP DETAILS TWO LANE ROADWAYS ..... TPR-120

*~ TEMPORARY ~*

TRAFFIC CONTROL

LANE CLOSURE TWO-LANE HIGHWAY ..... TTC-100-05  
SHOULDER CLOSURE ..... TTC-135-03

DEVICES

DOUBLE FINES ZONE SIGNS ..... TTD-120-03  
PAVEMENT CONDITION WARNING SIGNS ..... TTD-125-03

STRIPING OPERATIONS

MOBILE OPERATION FOR PAINT STRIPING CASE I ..... TTS-100-02  
MOBILE OPERATION FOR PAINT STRIPING CASE II ..... TTS-105-02  
MOBILE OPERATION FOR PAINT STRIPING CASE III ..... TTS-110-02  
MOBILE OPERATION FOR PAINT STRIPING CASE IV ..... TTS-115-02

**PART III**

**EMPLOYMENT, WAGE AND RECORD REQUIREMENTS**

FHWA-1273 -- Revised May 1, 2012

**REQUIRED CONTRACT PROVISIONS  
FEDERAL-AID CONSTRUCTION CONTRACTS**

- I. General
- II. Nondiscrimination
- III. Nonsegregated Facilities
- IV. Davis-Bacon and Related Act Provisions
- V. Contract Work Hours and Safety Standards Act Provisions
- VI. Subletting or Assigning the Contract
- VII. Safety: Accident Prevention
- VIII. False Statements Concerning Highway Projects
- IX. Implementation of Clean Air Act and Federal Water Pollution Control Act
- X. Compliance with Governmentwide Suspension and Debarment Requirements
- XI. Certification Regarding Use of Contract Funds for Lobbying

3. A breach of any of the stipulations contained in these Required Contract Provisions may be sufficient grounds for withholding of progress payments, withholding of final payment, termination of the contract, suspension / debarment or any other action determined to be appropriate by the contracting agency and FHWA.

4. Selection of Labor: During the performance of this contract, the contractor shall not use convict labor for any purpose within the limits of a construction project on a Federal-aid highway unless it is labor performed by convicts who are on parole, supervised release, or probation. The term Federal-aid highway does not include roadways functionally classified as local roads or rural minor collectors.

**ATTACHMENTS**

A. Employment and Materials Preference for Appalachian Development Highway System or Appalachian Local Access Road Contracts (included in Appalachian contracts only)

**II. NONDISCRIMINATION**

The provisions of this section related to 23 CFR Part 230 are applicable to all Federal-aid construction contracts and to all related construction subcontracts of \$10,000 or more. The provisions of 23 CFR Part 230 are not applicable to material supply, engineering, or architectural service contracts.

**I. GENERAL**

1. Form FHWA-1273 must be physically incorporated in each construction contract funded under Title 23 (excluding emergency contracts solely intended for debris removal). The contractor (or subcontractor) must insert this form in each subcontract and further require its inclusion in all lower tier subcontracts (excluding purchase orders, rental agreements and other agreements for supplies or services).

In addition, the contractor and all subcontractors must comply with the following policies: Executive Order 11246, 41 CFR 60, 29 CFR 1625-1627, Title 23 USC Section 140, the Rehabilitation Act of 1973, as amended (29 USC 794), Title VI of the Civil Rights Act of 1964, as amended, and related regulations including 49 CFR Parts 21, 26 and 27; and 23 CFR Parts 200, 230, and 633.

The applicable requirements of Form FHWA-1273 are incorporated by reference for work done under any purchase order, rental agreement or agreement for other services. The prime contractor shall be responsible for compliance by any subcontractor, lower-tier subcontractor or service provider.

The contractor and all subcontractors must comply with: the requirements of the Equal Opportunity Clause in 41 CFR 60-1.4(b) and, for all construction contracts exceeding \$10,000, the Standard Federal Equal Employment Opportunity Construction Contract Specifications in 41 CFR 60-4.3.

Form FHWA-1273 must be included in all Federal-aid design-build contracts, in all subcontracts and in lower tier subcontracts (excluding subcontracts for design services, purchase orders, rental agreements and other agreements for supplies or services). The design-builder shall be responsible for compliance by any subcontractor, lower-tier subcontractor or service provider.

Note: The U.S. Department of Labor has exclusive authority to determine compliance with Executive Order 11246 and the policies of the Secretary of Labor including 41 CFR 60, and 29 CFR 1625-1627. The contracting agency and the FHWA have the authority and the responsibility to ensure compliance with Title 23 USC Section 140, the Rehabilitation Act of 1973, as amended (29 USC 794), and Title VI of the Civil Rights Act of 1964, as amended, and related regulations including 49 CFR Parts 21, 26 and 27; and 23 CFR Parts 200, 230, and 633.

Contracting agencies may reference Form FHWA-1273 in bid proposal or request for proposal documents, however, the Form FHWA-1273 must be physically incorporated (not referenced) in all contracts, subcontracts and lower-tier subcontracts (excluding purchase orders, rental agreements and other agreements for supplies or services related to a construction contract).

The following provision is adopted from 23 CFR 230, Appendix A, with appropriate revisions to conform to the U.S. Department of Labor (US DOL) and FHWA requirements.

2. Subject to the applicability criteria noted in the following sections, these contract provisions shall apply to all work performed on the contract by the contractor's own organization and with the assistance of workers under the contractor's immediate superintendence and to all work performed on the contract by piecework, station work, or by subcontract.

**1. Equal Employment Opportunity:** Equal employment opportunity (EEO) requirements not to discriminate and to take affirmative action to assure equal opportunity as set forth under laws, executive orders, rules, regulations (28 CFR 35, 29 CFR 1630, 29 CFR 1625-1627, 41 CFR 60 and 49 CFR 27) and orders of the Secretary of Labor as modified by the provisions prescribed herein, and imposed pursuant to 23 U.S.C. 140 shall constitute the EEO and specific affirmative action standards for the contractor's project activities under

this contract. The provisions of the Americans with Disabilities Act of 1990 (42 U.S.C. 12101 et seq.) set forth under 28 CFR 35 and 29 CFR 1630 are incorporated by reference in this contract. In the execution of this contract, the contractor agrees to comply with the following minimum specific requirement activities of EEO:

a. The contractor will work with the contracting agency and the Federal Government to ensure that it has made every good faith effort to provide equal opportunity with respect to all of its terms and conditions of employment and in their review of activities under the contract.

b. The contractor will accept as its operating policy the following statement:

"It is the policy of this Company to assure that applicants are employed, and that employees are treated during employment, without regard to their race, religion, sex, color, national origin, age or disability. Such action shall include: employment, upgrading, demotion, or transfer; recruitment or recruitment advertising; layoff or termination; rates of pay or other forms of compensation; and selection for training, including apprenticeship, pre-apprenticeship, and/or on-the-job training."

**2. EEO Officer:** The contractor will designate and make known to the contracting officers an EEO Officer who will have the responsibility for and must be capable of effectively administering and promoting an active EEO program and who must be assigned adequate authority and responsibility to do so.

**3. Dissemination of Policy:** All members of the contractor's staff who are authorized to hire, supervise, promote, and discharge employees, or who recommend such action, or who are substantially involved in such action, will be made fully cognizant of, and will implement, the contractor's EEO policy and contractual responsibilities to provide EEO in each grade and classification of employment. To ensure that the above agreement will be met, the following actions will be taken as a minimum:

a. Periodic meetings of supervisory and personnel office employees will be conducted before the start of work and then not less often than once every six months, at which time the contractor's EEO policy and its implementation will be reviewed and explained. The meetings will be conducted by the EEO Officer.

b. All new supervisory or personnel office employees will be given a thorough indoctrination by the EEO Officer, covering all major aspects of the contractor's EEO obligations within thirty days following their reporting for duty with the contractor.

c. All personnel who are engaged in direct recruitment for the project will be instructed by the EEO Officer in the contractor's procedures for locating and hiring minorities and women.

d. Notices and posters setting forth the contractor's EEO policy will be placed in areas readily accessible to employees, applicants for employment and potential employees.

e. The contractor's EEO policy and the procedures to implement such policy will be brought to the attention of employees by means of meetings, employee handbooks, or other appropriate means.

**4. Recruitment:** When advertising for employees, the contractor will include in all advertisements for employees the notation: "An Equal Opportunity Employer." All such advertisements will be placed in publications having a large circulation among minorities and women in the area from which the project work force would normally be derived.

a. The contractor will, unless precluded by a valid bargaining agreement, conduct systematic and direct recruitment through public and private employee referral sources likely to yield qualified minorities and women. To meet this requirement, the contractor will identify sources of potential minority group employees, and establish with such identified sources procedures whereby minority and women applicants may be referred to the contractor for employment consideration.

b. In the event the contractor has a valid bargaining agreement providing for exclusive hiring hall referrals, the contractor is expected to observe the provisions of that agreement to the extent that the system meets the contractor's compliance with EEO contract provisions. Where implementation of such an agreement has the effect of discriminating against minorities or women, or obligates the contractor to do the same, such implementation violates Federal nondiscrimination provisions.

c. The contractor will encourage its present employees to refer minorities and women as applicants for employment. Information and procedures with regard to referring such applicants will be discussed with employees.

**5. Personnel Actions:** Wages, working conditions, and employee benefits shall be established and administered, and personnel actions of every type, including hiring, upgrading, promotion, transfer, demotion, layoff, and termination, shall be taken without regard to race, color, religion, sex, national origin, age or disability. The following procedures shall be followed:

a. The contractor will conduct periodic inspections of project sites to insure that working conditions and employee facilities do not indicate discriminatory treatment of project site personnel.

b. The contractor will periodically evaluate the spread of wages paid within each classification to determine any evidence of discriminatory wage practices.

c. The contractor will periodically review selected personnel actions in depth to determine whether there is evidence of discrimination. Where evidence is found, the contractor will promptly take corrective action. If the review indicates that the discrimination may extend beyond the actions reviewed, such corrective action shall include all affected persons.

d. The contractor will promptly investigate all complaints of alleged discrimination made to the contractor in connection with its obligations under this contract, will attempt to resolve such complaints, and will take appropriate corrective action within a reasonable time. If the investigation indicates that the discrimination may affect persons other than the complainant, such corrective action shall include such other persons. Upon completion of each investigation, the contractor will inform every complainant of all of their avenues of appeal.

**6. Training and Promotion:**

a. The contractor will assist in locating, qualifying, and increasing the skills of minorities and women who are

applicants for employment or current employees. Such efforts should be aimed at developing full journey level status employees in the type of trade or job classification involved.

b. Consistent with the contractor's work force requirements and as permissible under Federal and State regulations, the contractor shall make full use of training programs, i.e., apprenticeship, and on-the-job training programs for the geographical area of contract performance. In the event a special provision for training is provided under this contract, this subparagraph will be superseded as indicated in the special provision. The contracting agency may reserve training positions for persons who receive welfare assistance in accordance with 23 U.S.C. 140(a).

c. The contractor will advise employees and applicants for employment of available training programs and entrance requirements for each.

d. The contractor will periodically review the training and promotion potential of employees who are minorities and women and will encourage eligible employees to apply for such training and promotion.

**7. Unions:** If the contractor relies in whole or in part upon unions as a source of employees, the contractor will use good faith efforts to obtain the cooperation of such unions to increase opportunities for minorities and women. Actions by the contractor, either directly or through a contractor's association acting as agent, will include the procedures set forth below:

a. The contractor will use good faith efforts to develop, in cooperation with the unions, joint training programs aimed toward qualifying more minorities and women for membership in the unions and increasing the skills of minorities and women so that they may qualify for higher paying employment.

b. The contractor will use good faith efforts to incorporate an EEO clause into each union agreement to the end that such union will be contractually bound to refer applicants without regard to their race, color, religion, sex, national origin, age or disability.

c. The contractor is to obtain information as to the referral practices and policies of the labor union except that to the extent such information is within the exclusive possession of the labor union and such labor union refuses to furnish such information to the contractor, the contractor shall so certify to the contracting agency and shall set forth what efforts have been made to obtain such information.

d. In the event the union is unable to provide the contractor with a reasonable flow of referrals within the time limit set forth in the collective bargaining agreement, the contractor will, through independent recruitment efforts, fill the employment vacancies without regard to race, color, religion, sex, national origin, age or disability; making full efforts to obtain qualified and/or qualifiable minorities and women. The failure of a union to provide sufficient referrals (even though it is obligated to provide exclusive referrals under the terms of a collective bargaining agreement) does not relieve the contractor from the requirements of this paragraph. In the event the union referral practice prevents the contractor from meeting the obligations pursuant to Executive Order 11246, as amended, and these special provisions, such contractor shall immediately notify the contracting agency.

**8. Reasonable Accommodation for Applicants / Employees with Disabilities:** The contractor must be familiar

with the requirements for and comply with the Americans with Disabilities Act and all rules and regulations established there under. Employers must provide reasonable accommodation in all employment activities unless to do so would cause an undue hardship.

**9. Selection of Subcontractors, Procurement of Materials and Leasing of Equipment:** The contractor shall not discriminate on the grounds of race, color, religion, sex, national origin, age or disability in the selection and retention of subcontractors, including procurement of materials and leases of equipment. The contractor shall take all necessary and reasonable steps to ensure nondiscrimination in the administration of this contract.

a. The contractor shall notify all potential subcontractors and suppliers and lessors of their EEO obligations under this contract.

b. The contractor will use good faith efforts to ensure subcontractor compliance with their EEO obligations.

**10. Assurance Required by 49 CFR 26.13(b):**

a. The requirements of 49 CFR Part 26 and the State DOT's U.S. DOT-approved DBE program are incorporated by reference.

b. The contractor or subcontractor shall not discriminate on the basis of race, color, national origin, or sex in the performance of this contract. The contractor shall carry out applicable requirements of 49 CFR Part 26 in the award and administration of DOT-assisted contracts. Failure by the contractor to carry out these requirements is a material breach of this contract, which may result in the termination of this contract or such other remedy as the contracting agency deems appropriate.

**11. Records and Reports:** The contractor shall keep such records as necessary to document compliance with the EEO requirements. Such records shall be retained for a period of three years following the date of the final payment to the contractor for all contract work and shall be available at reasonable times and places for inspection by authorized representatives of the contracting agency and the FHWA.

a. The records kept by the contractor shall document the following:

(1) The number and work hours of minority and non-minority group members and women employed in each work classification on the project;

(2) The progress and efforts being made in cooperation with unions, when applicable, to increase employment opportunities for minorities and women; and

(3) The progress and efforts being made in locating, hiring, training, qualifying, and upgrading minorities and women;

b. The contractors and subcontractors will submit an annual report to the contracting agency each July for the duration of the project, indicating the number of minority, women, and non-minority group employees currently engaged in each work classification required by the contract work. This information is to be reported on [Form FHWA-1391](#). The staffing data should represent the project work force on board in all or any part of the last payroll period preceding the end of July. If on-the-job training is being required by special provision, the contractor

will be required to collect and report training data. The employment data should reflect the work force on board during all or any part of the last payroll period preceding the end of July.

**III. NONSEGREGATED FACILITIES**

This provision is applicable to all Federal-aid construction contracts and to all related construction subcontracts of \$10,000 or more.

The contractor must ensure that facilities provided for employees are provided in such a manner that segregation on the basis of race, color, religion, sex, or national origin cannot result. The contractor may neither require such segregated use by written or oral policies nor tolerate such use by employee custom. The contractor's obligation extends further to ensure that its employees are not assigned to perform their services at any location, under the contractor's control, where the facilities are segregated. The term "facilities" includes waiting rooms, work areas, restaurants and other eating areas, time clocks, restrooms, washrooms, locker rooms, and other storage or dressing areas, parking lots, drinking fountains, recreation or entertainment areas, transportation, and housing provided for employees. The contractor shall provide separate or single-user restrooms and necessary dressing or sleeping areas to assure privacy between sexes.

**IV. DAVIS-BACON AND RELATED ACT PROVISIONS**

This section is applicable to all Federal-aid construction projects exceeding \$2,000 and to all related subcontracts and lower-tier subcontracts (regardless of subcontract size). The requirements apply to all projects located within the right-of-way of a roadway that is functionally classified as Federal-aid highway. This excludes roadways functionally classified as local roads or rural minor collectors, which are exempt. Contracting agencies may elect to apply these requirements to other projects.

The following provisions are from the U.S. Department of Labor regulations in 29 CFR 5.5 "Contract provisions and related matters" with minor revisions to conform to the FHWA-1273 format and FHWA program requirements.

**1. Minimum wages**

a. All laborers and mechanics employed or working upon the site of the work, will be paid unconditionally and not less often than once a week, and without subsequent deduction or rebate on any account (except such payroll deductions as are permitted by regulations issued by the Secretary of Labor under the Copeland Act (29 CFR part 3)), the full amount of wages and bona fide fringe benefits (or cash equivalents thereof) due at time of payment computed at rates not less than those contained in the wage determination of the Secretary of Labor which is attached hereto and made a part hereof, regardless of any contractual relationship which may be alleged to exist between the contractor and such laborers and mechanics.

Contributions made or costs reasonably anticipated for bona fide fringe benefits under section 1(b)(2) of the Davis-Bacon Act on behalf of laborers or mechanics are considered wages paid to such laborers or mechanics, subject to the provisions

of paragraph 1.d. of this section; also, regular contributions made or costs incurred for more than a weekly period (but not less often than quarterly) under plans, funds, or programs which cover the particular weekly period, are deemed to be constructively made or incurred during such weekly period. Such laborers and mechanics shall be paid the appropriate wage rate and fringe benefits on the wage determination for the classification of work actually performed, without regard to skill, except as provided in 29 CFR 5.5(a)(4). Laborers or mechanics performing work in more than one classification may be compensated at the rate specified for each classification for the time actually worked therein: Provided, That the employer's payroll records accurately set forth the time spent in each classification in which work is performed. The wage determination (including any additional classification and wage rates conformed under paragraph 1.b. of this section) and the Davis-Bacon poster (WH-1321) shall be posted at all times by the contractor and its subcontractors at the site of the work in a prominent and accessible place where it can be easily seen by the workers.

b.(1) The contracting officer shall require that any class of laborers or mechanics, including helpers, which is not listed in the wage determination and which is to be employed under the contract shall be classified in conformance with the wage determination. The contracting officer shall approve an additional classification and wage rate and fringe benefits therefore only when the following criteria have been met:

- (i) The work to be performed by the classification requested is not performed by a classification in the wage determination; and
- (ii) The classification is utilized in the area by the construction industry; and
- (iii) The proposed wage rate, including any bona fide fringe benefits, bears a reasonable relationship to the wage rates contained in the wage determination.

(2) If the contractor and the laborers and mechanics to be employed in the classification (if known), or their representatives, and the contracting officer agree on the classification and wage rate (including the amount designated for fringe benefits where appropriate), a report of the action taken shall be sent by the contracting officer to the Administrator of the Wage and Hour Division, Employment Standards Administration, U.S. Department of Labor, Washington, DC 20210. The Administrator, or an authorized representative, will approve, modify, or disapprove every additional classification action within 30 days of receipt and so advise the contracting officer or will notify the contracting officer within the 30-day period that additional time is necessary.

(3) In the event the contractor, the laborers or mechanics to be employed in the classification or their representatives, and the contracting officer do not agree on the proposed classification and wage rate (including the amount designated for fringe benefits, where appropriate), the contracting officer shall refer the questions, including the views of all interested parties and the recommendation of the contracting officer, to the Wage and Hour Administrator for determination. The Wage and Hour Administrator, or an authorized representative, will issue a determination within 30 days of receipt and so advise the contracting officer or

will notify the contracting officer within the 30-day period that additional time is necessary.

(4) The wage rate (including fringe benefits where appropriate) determined pursuant to paragraphs 1.b.(2) or 1.b.(3) of this section, shall be paid to all workers performing work in the classification under this contract from the first day on which work is performed in the classification.

c. Whenever the minimum wage rate prescribed in the contract for a class of laborers or mechanics includes a fringe benefit which is not expressed as an hourly rate, the contractor shall either pay the benefit as stated in the wage determination or shall pay another bona fide fringe benefit or an hourly cash equivalent thereof.

d. If the contractor does not make payments to a trustee or other third person, the contractor may consider as part of the wages of any laborer or mechanic the amount of any costs reasonably anticipated in providing bona fide fringe benefits under a plan or program. Provided, That the Secretary of Labor has found, upon the written request of the contractor, that the applicable standards of the Davis-Bacon Act have been met. The Secretary of Labor may require the contractor to set aside in a separate account assets for the meeting of obligations under the plan or program.

## 2. Withholding

The contracting agency shall upon its own action or upon written request of an authorized representative of the Department of Labor, withhold or cause to be withheld from the contractor under this contract, or any other Federal contract with the same prime contractor, or any other federally-assisted contract subject to Davis-Bacon prevailing wage requirements, which is held by the same prime contractor, so much of the accrued payments or advances as may be considered necessary to pay laborers and mechanics, including apprentices, trainees, and helpers, employed by the contractor or any subcontractor the full amount of wages required by the contract. In the event of failure to pay any laborer or mechanic, including any apprentice, trainee, or helper, employed or working on the site of the work, all or part of the wages required by the contract, the contracting agency may, after written notice to the contractor, take such action as may be necessary to cause the suspension of any further payment, advance, or guarantee of funds until such violations have ceased.

## 3. Payrolls and basic records

a. Payrolls and basic records relating thereto shall be maintained by the contractor during the course of the work and preserved for a period of three years thereafter for all laborers and mechanics working at the site of the work. Such records shall contain the name, address, and social security number of each such worker, his or her correct classification, hourly rates of wages paid (including rates of contributions or costs anticipated for bona fide fringe benefits or cash equivalents thereof of the types described in section 1(b)(2)(B) of the Davis-Bacon Act), daily and weekly number of hours worked, deductions made and actual wages paid. Whenever the Secretary of Labor has found under 29 CFR 5.5(a)(1)(iv) that the wages of any laborer or mechanic include the amount of any costs reasonably anticipated in providing benefits under a plan or program described in section 1(b)(2)(B) of the Davis-

Bacon Act, the contractor shall maintain records which show that the commitment to provide such benefits is enforceable, that the plan or program is financially responsible, and that the plan or program has been communicated in writing to the laborers or mechanics affected, and records which show the costs anticipated or the actual cost incurred in providing such benefits. Contractors employing apprentices or trainees under approved programs shall maintain written evidence of the registration of apprenticeship programs and certification of trainee programs, the registration of the apprentices and trainees, and the ratios and wage rates prescribed in the applicable programs.

b. (1) The contractor shall submit weekly for each week in which any contract work is performed a copy of all payrolls to the contracting agency. The payrolls submitted shall set out accurately and completely all of the information required to be maintained under 29 CFR 5.5(a)(3)(i), except that full social security numbers and home addresses shall not be included on weekly transmittals. Instead the payrolls shall only need to include an individually identifying number for each employee (e.g., the last four digits of the employee's social security number). The required weekly payroll information may be submitted in any form desired. Optional Form WH-347 is available for this purpose from the Wage and Hour Division Web site at <http://www.dol.gov/esa/whd/forms/wh347instr.htm> or its successor site. The prime contractor is responsible for the submission of copies of payrolls by all subcontractors. Contractors and subcontractors shall maintain the full social security number and current address of each covered worker, and shall provide them upon request to the contracting agency for transmission to the State DOT, the FHWA or the Wage and Hour Division of the Department of Labor for purposes of an investigation or audit of compliance with prevailing wage requirements. It is not a violation of this section for a prime contractor to require a subcontractor to provide addresses and social security numbers to the prime contractor for its own records, without weekly submission to the contracting agency..

(2) Each payroll submitted shall be accompanied by a "Statement of Compliance," signed by the contractor or subcontractor or his or her agent who pays or supervises the payment of the persons employed under the contract and shall certify the following:

(i) That the payroll for the payroll period contains the information required to be provided under §5.5 (a)(3)(ii) of Regulations, 29 CFR part 5, the appropriate information is being maintained under §5.5 (a)(3)(i) of Regulations, 29 CFR part 5, and that such information is correct and complete;

(ii) That each laborer or mechanic (including each helper, apprentice, and trainee) employed on the contract during the payroll period has been paid the full weekly wages earned, without rebate, either directly or indirectly, and that no deductions have been made either directly or indirectly from the full wages earned, other than permissible deductions as set forth in Regulations, 29 CFR part 3;

(iii) That each laborer or mechanic has been paid not less than the applicable wage rates and fringe benefits or cash equivalents for the classification of work performed, as specified in the applicable wage determination incorporated into the contract.

(3) The weekly submission of a properly executed certification set forth on the reverse side of Optional Form WH-347 shall satisfy the requirement for submission of the "Statement of Compliance" required by paragraph 3.b.(2) of this section.

(4) The falsification of any of the above certifications may subject the contractor or subcontractor to civil or criminal prosecution under section 1001 of title 18 and section 231 of title 31 of the United States Code.

c. The contractor or subcontractor shall make the records required under paragraph 3.a. of this section available for inspection, copying, or transcription by authorized representatives of the contracting agency, the State DOT, the FHWA, or the Department of Labor, and shall permit such representatives to interview employees during working hours on the job. If the contractor or subcontractor fails to submit the required records or to make them available, the FHWA may, after written notice to the contractor, the contracting agency or the State DOT, take such action as may be necessary to cause the suspension of any further payment, advance, or guarantee of funds. Furthermore, failure to submit the required records upon request or to make such records available may be grounds for debarment action pursuant to 29 CFR 5.12.

#### 4. Apprentices and trainees

##### a. Apprentices (programs of the USDOL).

Apprentices will be permitted to work at less than the predetermined rate for the work they performed when they are employed pursuant to and individually registered in a bona fide apprenticeship program registered with the U.S. Department of Labor, Employment and Training Administration, Office of Apprenticeship Training, Employer and Labor Services, or with a State Apprenticeship Agency recognized by the Office, or if a person is employed in his or her first 90 days of probationary employment as an apprentice in such an apprenticeship program, who is not individually registered in the program, but who has been certified by the Office of Apprenticeship Training, Employer and Labor Services or a State Apprenticeship Agency (where appropriate) to be eligible for probationary employment as an apprentice.

The allowable ratio of apprentices to journeymen on the job site in any craft classification shall not be greater than the ratio permitted to the contractor as to the entire work force under the registered program. Any worker listed on a payroll at an apprentice wage rate, who is not registered or otherwise employed as stated above, shall be paid not less than the applicable wage rate on the wage determination for the classification of work actually performed. In addition, any apprentice performing work on the job site in excess of the ratio permitted under the registered program shall be paid not less than the applicable wage rate on the wage determination for the work actually performed. Where a contractor is performing construction on a project in a locality other than that in which its program is registered, the ratios and wage rates (expressed in percentages of the journeyman's hourly rate) specified in the contractor's or subcontractor's registered program shall be observed.

Every apprentice must be paid at not less than the rate specified in the registered program for the apprentice's level of progress, expressed as a percentage of the journeymen hourly

rate specified in the applicable wage determination. Apprentices shall be paid fringe benefits in accordance with the provisions of the apprenticeship program. If the apprenticeship program does not specify fringe benefits, apprentices must be paid the full amount of fringe benefits listed on the wage determination for the applicable classification. If the Administrator determines that a different practice prevails for the applicable apprentice classification, fringes shall be paid in accordance with that determination.

In the event the Office of Apprenticeship Training, Employer and Labor Services, or a State Apprenticeship Agency recognized by the Office, withdraws approval of an apprenticeship program, the contractor will no longer be permitted to utilize apprentices at less than the applicable predetermined rate for the work performed until an acceptable program is approved.

##### b. Trainees (programs of the USDOL).

Except as provided in 29 CFR 5.16, trainees will not be permitted to work at less than the predetermined rate for the work performed unless they are employed pursuant to and individually registered in a program which has received prior approval, evidenced by formal certification by the U.S. Department of Labor, Employment and Training Administration.

The ratio of trainees to journeymen on the job site shall not be greater than permitted under the plan approved by the Employment and Training Administration.

Every trainee must be paid at not less than the rate specified in the approved program for the trainee's level of progress, expressed as a percentage of the journeyman hourly rate specified in the applicable wage determination. Trainees shall be paid fringe benefits in accordance with the provisions of the trainee program. If the trainee program does not mention fringe benefits, trainees shall be paid the full amount of fringe benefits listed on the wage determination unless the Administrator of the Wage and Hour Division determines that there is an apprenticeship program associated with the corresponding journeyman wage rate on the wage determination which provides for less than full fringe benefits for apprentices. Any employee listed on the payroll at a trainee rate who is not registered and participating in a training plan approved by the Employment and Training Administration shall be paid not less than the applicable wage rate on the wage determination for the classification of work actually performed. In addition, any trainee performing work on the job site in excess of the ratio permitted under the registered program shall be paid not less than the applicable wage rate on the wage determination for the work actually performed.

In the event the Employment and Training Administration withdraws approval of a training program, the contractor will no longer be permitted to utilize trainees at less than the applicable predetermined rate for the work performed until an acceptable program is approved.

c. Equal employment opportunity. The utilization of apprentices, trainees and journeymen under this part shall be in conformity with the equal employment opportunity requirements of Executive Order 11246, as amended, and 29 CFR part 30.

d. Apprentices and Trainees (programs of the U.S. DOT).

Apprentices and trainees working under apprenticeship and skill training programs which have been certified by the Secretary of Transportation as promoting EEO in connection with Federal-aid highway construction programs are not subject to the requirements of paragraph 4 of this Section IV. The straight time hourly wage rates for apprentices and trainees under such programs will be established by the particular programs. The ratio of apprentices and trainees to journeymen shall not be greater than permitted by the terms of the particular program.

**5. Compliance with Copeland Act requirements.** The contractor shall comply with the requirements of 29 CFR part 3, which are incorporated by reference in this contract.

**6. Subcontracts.** The contractor or subcontractor shall insert Form FHWA-1273 in any subcontracts and also require the subcontractors to include Form FHWA-1273 in any lower tier subcontracts. The prime contractor shall be responsible for the compliance by any subcontractor or lower tier subcontractor with all the contract clauses in 29 CFR 5.5.

**7. Contract termination: debarment.** A breach of the contract clauses in 29 CFR 5.5 may be grounds for termination of the contract, and for debarment as a contractor and a subcontractor as provided in 29 CFR 5.12.

**8. Compliance with Davis-Bacon and Related Act requirements.** All rulings and interpretations of the Davis-Bacon and Related Acts contained in 29 CFR parts 1, 3, and 5 are herein incorporated by reference in this contract.

**9. Disputes concerning labor standards.** Disputes arising out of the labor standards provisions of this contract shall not be subject to the general disputes clause of this contract. Such disputes shall be resolved in accordance with the procedures of the Department of Labor set forth in 29 CFR parts 5, 6, and 7. Disputes within the meaning of this clause include disputes between the contractor (or any of its subcontractors) and the contracting agency, the U.S. Department of Labor, or the employees or their representatives.

**10. Certification of eligibility.**

a. By entering into this contract, the contractor certifies that neither it (nor he or she) nor any person or firm who has an interest in the contractor's firm is a person or firm ineligible to be awarded Government contracts by virtue of section 3(a) of the Davis-Bacon Act or 29 CFR 5.12(a)(1).

b. No part of this contract shall be subcontracted to any person or firm ineligible for award of a Government contract by virtue of section 3(a) of the Davis-Bacon Act or 29 CFR 5.12(a)(1).

c. The penalty for making false statements is prescribed in the U.S. Criminal Code, 18 U.S.C. 1001.

**V. CONTRACT WORK HOURS AND SAFETY STANDARDS ACT**

The following clauses apply to any Federal-aid construction contract in an amount in excess of \$100,000 and subject to the overtime provisions of the Contract Work Hours and Safety Standards Act. These clauses shall be inserted in addition to the clauses required by 29 CFR 5.5(a) or 29 CFR 4.6. As used in this paragraph, the terms laborers and mechanics include watchmen and guards.

**1. Overtime requirements.** No contractor or subcontractor contracting for any part of the contract work which may require or involve the employment of laborers or mechanics shall require or permit any such laborer or mechanic in any workweek in which he or she is employed on such work to work in excess of forty hours in such workweek unless such laborer or mechanic receives compensation at a rate not less than one and one-half times the basic rate of pay for all hours worked in excess of forty hours in such workweek.

**2. Violation; liability for unpaid wages; liquidated damages.** In the event of any violation of the clause set forth in paragraph (1.) of this section, the contractor and any subcontractor responsible therefor shall be liable for the unpaid wages. In addition, such contractor and subcontractor shall be liable to the United States (in the case of work done under contract for the District of Columbia or a territory, to such District or to such territory), for liquidated damages. Such liquidated damages shall be computed with respect to each individual laborer or mechanic, including watchmen and guards, employed in violation of the clause set forth in paragraph (1.) of this section, in the sum of \$10 for each calendar day on which such individual was required or permitted to work in excess of the standard workweek of forty hours without payment of the overtime wages required by the clause set forth in paragraph (1.) of this section.

**3. Withholding for unpaid wages and liquidated damages.** The FHWA or the contracting agency shall upon its own action or upon written request of an authorized representative of the Department of Labor withhold or cause to be withheld, from any moneys payable on account of work performed by the contractor or subcontractor under any such contract or any other Federal contract with the same prime contractor, or any other federally-assisted contract subject to the Contract Work Hours and Safety Standards Act, which is held by the same prime contractor, such sums as may be determined to be necessary to satisfy any liabilities of such contractor or subcontractor for unpaid wages and liquidated damages as provided in the clause set forth in paragraph (2.) of this section.

**4. Subcontracts.** The contractor or subcontractor shall insert in any subcontracts the clauses set forth in paragraph (1.) through (4.) of this section and also a clause requiring the subcontractors to include these clauses in any lower tier subcontracts. The prime contractor shall be responsible for compliance by any subcontractor or lower tier subcontractor with the clauses set forth in paragraphs (1.) through (4.) of this section.

**VI. SUBLETTING OR ASSIGNING THE CONTRACT**

This provision is applicable to all Federal-aid construction contracts on the National Highway System.

1. The contractor shall perform with its own organization contract work amounting to not less than 30 percent (or a greater percentage if specified elsewhere in the contract) of the total original contract price, excluding any specialty items designated by the contracting agency. Specialty items may be performed by subcontract and the amount of any such specialty items performed may be deducted from the total original contract price before computing the amount of work required to be performed by the contractor's own organization (23 CFR 635.116).

a. The term "perform work with its own organization" refers to workers employed or leased by the prime contractor, and equipment owned or rented by the prime contractor, with or without operators. Such term does not include employees or equipment of a subcontractor or lower tier subcontractor, agents of the prime contractor, or any other assignees. The term may include payments for the costs of hiring leased employees from an employee leasing firm meeting all relevant Federal and State regulatory requirements. Leased employees may only be included in this term if the prime contractor meets all of the following conditions:

- (1) the prime contractor maintains control over the supervision of the day-to-day activities of the leased employees;
- (2) the prime contractor remains responsible for the quality of the work of the leased employees;
- (3) the prime contractor retains all power to accept or exclude individual employees from work on the project; and
- (4) the prime contractor remains ultimately responsible for the payment of predetermined minimum wages, the submission of payrolls, statements of compliance and all other Federal regulatory requirements.

b. "Specialty Items" shall be construed to be limited to work that requires highly specialized knowledge, abilities, or equipment not ordinarily available in the type of contracting organizations qualified and expected to bid or propose on the contract as a whole and in general are to be limited to minor components of the overall contract.

2. The contract amount upon which the requirements set forth in paragraph (1) of Section VI is computed includes the cost of material and manufactured products which are to be purchased or produced by the contractor under the contract provisions.

3. The contractor shall furnish (a) a competent superintendent or supervisor who is employed by the firm, has full authority to direct performance of the work in accordance with the contract requirements, and is in charge of all construction operations (regardless of who performs the work) and (b) such other of its own organizational resources (supervision, management, and engineering services) as the contracting officer determines is necessary to assure the performance of the contract.

4. No portion of the contract shall be sublet, assigned or otherwise disposed of except with the written consent of the contracting officer, or authorized representative, and such consent when given shall not be construed to relieve the contractor of any responsibility for the fulfillment of the contract. Written consent will be given only after the contracting agency has assured that each subcontract is

evidenced in writing and that it contains all pertinent provisions and requirements of the prime contract.

5. The 30% self-performance requirement of paragraph (1) is not applicable to design-build contracts; however, contracting agencies may establish their own self-performance requirements.

**VII. SAFETY: ACCIDENT PREVENTION**

This provision is applicable to all Federal-aid construction contracts and to all related subcontracts.

1. In the performance of this contract the contractor shall comply with all applicable Federal, State, and local laws governing safety, health, and sanitation (23 CFR 635). The contractor shall provide all safeguards, safety devices and protective equipment and take any other needed actions as it determines, or as the contracting officer may determine, to be reasonably necessary to protect the life and health of employees on the job and the safety of the public and to protect property in connection with the performance of the work covered by the contract.

2. It is a condition of this contract, and shall be made a condition of each subcontract, which the contractor enters into pursuant to this contract, that the contractor and any subcontractor shall not permit any employee, in performance of the contract, to work in surroundings or under conditions which are unsanitary, hazardous or dangerous to his/her health or safety, as determined under construction safety and health standards (29 CFR 1926) promulgated by the Secretary of Labor, in accordance with Section 107 of the Contract Work Hours and Safety Standards Act (40 U.S.C. 3704).

3. Pursuant to 29 CFR 1926.3, it is a condition of this contract that the Secretary of Labor or authorized representative thereof, shall have right of entry to any site of contract performance to inspect or investigate the matter of compliance with the construction safety and health standards and to carry out the duties of the Secretary under Section 107 of the Contract Work Hours and Safety Standards Act (40 U.S.C.3704).

**VIII. FALSE STATEMENTS CONCERNING HIGHWAY PROJECTS**

This provision is applicable to all Federal-aid construction contracts and to all related subcontracts.

In order to assure high quality and durable construction in conformity with approved plans and specifications and a high degree of reliability on statements and representations made by engineers, contractors, suppliers, and workers on Federal-aid highway projects, it is essential that all persons concerned with the project perform their functions as carefully, thoroughly, and honestly as possible. Willful falsification, distortion, or misrepresentation with respect to any facts related to the project is a violation of Federal law. To prevent any misunderstanding regarding the seriousness of these and similar acts, Form FHWA-1022 shall be posted on each Federal-aid highway project (23 CFR 635) in one or more places where it is readily available to all persons concerned with the project:

18 U.S.C. 1020 reads as follows:

"Whoever, being an officer, agent, or employee of the United States, or of any State or Territory, or whoever, whether a person, association, firm, or corporation, knowingly makes any false statement, false representation, or false report as to the character, quality, quantity, or cost of the material used or to be used, or the quantity or quality of the work performed or to be performed, or the cost thereof in connection with the submission of plans, maps, specifications, contracts, or costs of construction on any highway or related project submitted for approval to the Secretary of Transportation; or

Whoever knowingly makes any false statement, false representation, false report or false claim with respect to the character, quality, quantity, or cost of any work performed or to be performed, or materials furnished or to be furnished, in connection with the construction of any highway or related project approved by the Secretary of Transportation; or

Whoever knowingly makes any false statement or false representation as to material fact in any statement, certificate, or report submitted pursuant to provisions of the Federal-aid Roads Act approved July 1, 1916, (39 Stat. 355), as amended and supplemented;

Shall be fined under this title or imprisoned not more than 5 years or both."

**IX. IMPLEMENTATION OF CLEAN AIR ACT AND FEDERAL WATER POLLUTION CONTROL ACT**

This provision is applicable to all Federal-aid construction contracts and to all related subcontracts.

By submission of this bid/proposal or the execution of this contract, or subcontract, as appropriate, the bidder, proposer, Federal-aid construction contractor, or subcontractor, as appropriate, will be deemed to have stipulated as follows:

1. That any person who is or will be utilized in the performance of this contract is not prohibited from receiving an award due to a violation of Section 508 of the Clean Water Act or Section 306 of the Clean Air Act.

2. That the contractor agrees to include or cause to be included the requirements of paragraph (1) of this Section X in every subcontract, and further agrees to take such action as the contracting agency may direct as a means of enforcing such requirements.

**X. CERTIFICATION REGARDING DEBARMENT, SUSPENSION, INELIGIBILITY AND VOLUNTARY EXCLUSION**

This provision is applicable to all Federal-aid construction contracts, design-build contracts, subcontracts, lower-tier subcontracts, purchase orders, lease agreements, consultant contracts or any other covered transaction requiring FHWA approval or that is estimated to cost \$25,000 or more – as defined in 2 CFR Parts 180 and 1200.

**1. Instructions for Certification – First Tier Participants:**

a. By signing and submitting this proposal, the prospective first tier participant is providing the certification set out below.

b. The inability of a person to provide the certification set out below will not necessarily result in denial of participation in this

covered transaction. The prospective first tier participant shall submit an explanation of why it cannot provide the certification set out below. The certification or explanation will be considered in connection with the department or agency's determination whether to enter into this transaction. However, failure of the prospective first tier participant to furnish a certification or an explanation shall disqualify such a person from participation in this transaction.

c. The certification in this clause is a material representation of fact upon which reliance was placed when the contracting agency determined to enter into this transaction. If it is later determined that the prospective participant knowingly rendered an erroneous certification, in addition to other remedies available to the Federal Government, the contracting agency may terminate this transaction for cause of default.

d. The prospective first tier participant shall provide immediate written notice to the contracting agency to whom this proposal is submitted if any time the prospective first tier participant learns that its certification was erroneous when submitted or has become erroneous by reason of changed circumstances.

e. The terms "covered transaction," "debarred," "suspended," "ineligible," "participant," "person," "principal," and "voluntarily excluded," as used in this clause, are defined in 2 CFR Parts 180 and 1200. "First Tier Covered Transactions" refers to any covered transaction between a grantee or subgrantee of Federal funds and a participant (such as the prime or general contract). "Lower Tier Covered Transactions" refers to any covered transaction under a First Tier Covered Transaction (such as subcontracts). "First Tier Participant" refers to the participant who has entered into a covered transaction with a grantee or subgrantee of Federal funds (such as the prime or general contractor). "Lower Tier Participant" refers any participant who has entered into a covered transaction with a First Tier Participant or other Lower Tier Participants (such as subcontractors and suppliers).

f. The prospective first tier participant agrees by submitting this proposal that, should the proposed covered transaction be entered into, it shall not knowingly enter into any lower tier covered transaction with a person who is debarred, suspended, declared ineligible, or voluntarily excluded from participation in this covered transaction, unless authorized by the department or agency entering into this transaction.

g. The prospective first tier participant further agrees by submitting this proposal that it will include the clause titled "Certification Regarding Debarment, Suspension, Ineligibility and Voluntary Exclusion-Lower Tier Covered Transactions," provided by the department or contracting agency, entering into this covered transaction, without modification, in all lower tier covered transactions and in all solicitations for lower tier covered transactions exceeding the \$25,000 threshold.

h. A participant in a covered transaction may rely upon a certification of a prospective participant in a lower tier covered transaction that is not debarred, suspended, ineligible, or voluntarily excluded from the covered transaction, unless it knows that the certification is erroneous. A participant is responsible for ensuring that its principals are not suspended, debarred, or otherwise ineligible to participate in covered transactions. To verify the eligibility of its principals, as well as the eligibility of any lower tier prospective participants, each participant may, but is not required to, check the Excluded Parties List System website (<https://www.epls.gov/>), which is compiled by the General Services Administration.

i. Nothing contained in the foregoing shall be construed to require the establishment of a system of records in order to render in good faith the certification required by this clause. The knowledge and information of the prospective participant is not required to exceed that which is normally possessed by a prudent person in the ordinary course of business dealings.

j. Except for transactions authorized under paragraph (f) of these instructions, if a participant in a covered transaction knowingly enters into a lower tier covered transaction with a person who is suspended, debarred, ineligible, or voluntarily excluded from participation in this transaction, in addition to other remedies available to the Federal Government, the department or agency may terminate this transaction for cause or default.

\*\*\*\*\*

**2. Certification Regarding Debarment, Suspension, Ineligibility and Voluntary Exclusion – First Tier Participants:**

a. The prospective first tier participant certifies to the best of its knowledge and belief, that it and its principals:

(1) Are not presently debarred, suspended, proposed for debarment, declared ineligible, or voluntarily excluded from participating in covered transactions by any Federal department or agency;

(2) Have not within a three-year period preceding this proposal been convicted of or had a civil judgment rendered against them for commission of fraud or a criminal offense in connection with obtaining, attempting to obtain, or performing a public (Federal, State or local) transaction or contract under a public transaction; violation of Federal or State antitrust statutes or commission of embezzlement, theft, forgery, bribery, falsification or destruction of records, making false statements, or receiving stolen property;

(3) Are not presently indicted for or otherwise criminally or civilly charged by a governmental entity (Federal, State or local) with commission of any of the offenses enumerated in paragraph (a)(2) of this certification; and

(4) Have not within a three-year period preceding this application/proposal had one or more public transactions (Federal, State or local) terminated for cause or default.

b. Where the prospective participant is unable to certify to any of the statements in this certification, such prospective participant shall attach an explanation to this proposal.

**2. Instructions for Certification - Lower Tier Participants:**

(Applicable to all subcontracts, purchase orders and other lower tier transactions requiring prior FHWA approval or estimated to cost \$25,000 or more - 2 CFR Parts 180 and 1200)

a. By signing and submitting this proposal, the prospective lower tier is providing the certification set out below.

b. The certification in this clause is a material representation of fact upon which reliance was placed when this transaction was entered into. If it is later determined that the prospective lower tier participant knowingly rendered an erroneous certification, in addition to other remedies available to the Federal Government, the department, or agency with which

this transaction originated may pursue available remedies, including suspension and/or debarment.

c. The prospective lower tier participant shall provide immediate written notice to the person to which this proposal is submitted if at any time the prospective lower tier participant learns that its certification was erroneous by reason of changed circumstances.

d. The terms "covered transaction," "debarred," "suspended," "ineligible," "participant," "person," "principal," and "voluntarily excluded," as used in this clause, are defined in 2 CFR Parts 180 and 1200. You may contact the person to which this proposal is submitted for assistance in obtaining a copy of those regulations. "First Tier Covered Transactions" refers to any covered transaction between a grantee or subgrantee of Federal funds and a participant (such as the prime or general contract). "Lower Tier Covered Transactions" refers to any covered transaction under a First Tier Covered Transaction (such as subcontracts). "First Tier Participant" refers to the participant who has entered into a covered transaction with a grantee or subgrantee of Federal funds (such as the prime or general contractor). "Lower Tier Participant" refers any participant who has entered into a covered transaction with a First Tier Participant or other Lower Tier Participants (such as subcontractors and suppliers).

e. The prospective lower tier participant agrees by submitting this proposal that, should the proposed covered transaction be entered into, it shall not knowingly enter into any lower tier covered transaction with a person who is debarred, suspended, declared ineligible, or voluntarily excluded from participation in this covered transaction, unless authorized by the department or agency with which this transaction originated.

f. The prospective lower tier participant further agrees by submitting this proposal that it will include this clause titled "Certification Regarding Debarment, Suspension, Ineligibility and Voluntary Exclusion-Lower Tier Covered Transaction," without modification, in all lower tier covered transactions and in all solicitations for lower tier covered transactions exceeding the \$25,000 threshold.

g. A participant in a covered transaction may rely upon a certification of a prospective participant in a lower tier covered transaction that is not debarred, suspended, ineligible, or voluntarily excluded from the covered transaction, unless it knows that the certification is erroneous. A participant is responsible for ensuring that its principals are not suspended, debarred, or otherwise ineligible to participate in covered transactions. To verify the eligibility of its principals, as well as the eligibility of any lower tier prospective participants, each participant may, but is not required to, check the Excluded Parties List System website (<https://www.epls.gov/>), which is compiled by the General Services Administration.

h. Nothing contained in the foregoing shall be construed to require establishment of a system of records in order to render in good faith the certification required by this clause. The knowledge and information of participant is not required to exceed that which is normally possessed by a prudent person in the ordinary course of business dealings.

i. Except for transactions authorized under paragraph e of these instructions, if a participant in a covered transaction knowingly enters into a lower tier covered transaction with a person who is suspended, debarred, ineligible, or voluntarily excluded from participation in this transaction, in addition to other remedies available to the Federal Government, the

department or agency with which this transaction originated may pursue available remedies, including suspension and/or debarment.

\* \* \* \* \*

**Certification Regarding Debarment, Suspension, Ineligibility and Voluntary Exclusion--Lower Tier Participants:**

1. The prospective lower tier participant certifies, by submission of this proposal, that neither it nor its principals is presently debarred, suspended, proposed for debarment, declared ineligible, or voluntarily excluded from participating in covered transactions by any Federal department or agency.

2. Where the prospective lower tier participant is unable to certify to any of the statements in this certification, such prospective participant shall attach an explanation to this proposal.

\* \* \* \* \*

**XI. CERTIFICATION REGARDING USE OF CONTRACT FUNDS FOR LOBBYING**

This provision is applicable to all Federal-aid construction contracts and to all related subcontracts which exceed \$100,000 (49 CFR 20).

1. The prospective participant certifies, by signing and submitting this bid or proposal, to the best of his or her knowledge and belief, that:

a. No Federal appropriated funds have been paid or will be paid, by or on behalf of the undersigned, to any person for influencing or attempting to influence an officer or employee of any Federal agency, a Member of Congress, an officer or employee of Congress, or an employee of a Member of Congress in connection with the awarding of any Federal contract, the making of any Federal grant, the making of any Federal loan, the entering into of any cooperative agreement, and the extension, continuation, renewal, amendment, or modification of any Federal contract, grant, loan, or cooperative agreement.

b. If any funds other than Federal appropriated funds have been paid or will be paid to any person for influencing or attempting to influence an officer or employee of any Federal agency, a Member of Congress, an officer or employee of Congress, or an employee of a Member of Congress in connection with this Federal contract, grant, loan, or cooperative agreement, the undersigned shall complete and submit Standard Form-LLL, "Disclosure Form to Report Lobbying," in accordance with its instructions.

2. This certification is a material representation of fact upon which reliance was placed when this transaction was made or entered into. Submission of this certification is a prerequisite for making or entering into this transaction imposed by 31 U.S.C. 1352. Any person who fails to file the required certification shall be subject to a civil penalty of not less than \$10,000 and not more than \$100,000 for each such failure.

3. The prospective participant also agrees by submitting its bid or proposal that the participant shall require that the language of this certification be included in all lower tier subcontracts, which exceed \$100,000 and that all such recipients shall certify and disclose accordingly.

**ATTACHMENT A - EMPLOYMENT AND MATERIALS  
PREFERENCE FOR APPALACHIAN DEVELOPMENT  
HIGHWAY SYSTEM OR APPALACHIAN LOCAL ACCESS  
ROAD CONTRACTS**

This provision is applicable to all Federal-aid projects funded under the Appalachian Regional Development Act of 1965.

1. During the performance of this contract, the contractor undertaking to do work which is, or reasonably may be, done as on-site work, shall give preference to qualified persons who regularly reside in the labor area as designated by the DOL wherein the contract work is situated, or the subregion, or the Appalachian counties of the State wherein the contract work is situated, except:

a. To the extent that qualified persons regularly residing in the area are not available.

b. For the reasonable needs of the contractor to employ supervisory or specially experienced personnel necessary to assure an efficient execution of the contract work.

c. For the obligation of the contractor to offer employment to present or former employees as the result of a lawful collective bargaining contract, provided that the number of nonresident persons employed under this subparagraph (1c) shall not exceed 20 percent of the total number of employees employed by the contractor on the contract work, except as provided in subparagraph (4) below.

2. The contractor shall place a job order with the State Employment Service indicating (a) the classifications of the laborers, mechanics and other employees required to perform the contract work, (b) the number of employees required in each classification, (c) the date on which the participant estimates such employees will be required, and (d) any other pertinent information required by the State Employment Service to complete the job order form. The job order may be placed with the State Employment Service in writing or by telephone. If during the course of the contract work, the information submitted by the contractor in the original job order is substantially modified, the participant shall promptly notify the State Employment Service.

3. The contractor shall give full consideration to all qualified job applicants referred to him by the State Employment Service. The contractor is not required to grant employment to any job applicants who, in his opinion, are not qualified to perform the classification of work required.

4. If, within one week following the placing of a job order by the contractor with the State Employment Service, the State Employment Service is unable to refer any qualified job applicants to the contractor, or less than the number requested, the State Employment Service will forward a certificate to the contractor indicating the unavailability of applicants. Such certificate shall be made a part of the contractor's permanent project records. Upon receipt of this certificate, the contractor may employ persons who do not normally reside in the labor area to fill positions covered by the certificate, notwithstanding the provisions of subparagraph (1c) above.

5. The provisions of 23 CFR 633.207(e) allow the contracting agency to provide a contractual preference for the use of mineral resource materials native to the Appalachian region.

6. The contractor shall include the provisions of Sections 1 through 4 of this Attachment A in every subcontract for work which is, or reasonably may be, done as on-site work.

**KENTUCKY TRANSPORTATION CABINET  
DEPARTMENT OF HIGHWAYS**

**EMPLOYMENT REQUIREMENTS  
RELATING TO  
NONDISCRIMINATION OF EMPLOYEES  
(APPLICABLE TO FEDERAL-AID SYSTEM CONTRACTS)**

**AN ACT OF THE KENTUCKY GENERAL ASSEMBLY  
TO PREVENT DISCRIMINATION IN EMPLOYMENT**

**KRS CHAPTER 344  
EFFECTIVE JUNE 16, 1972**

The contract on this project, in accordance with KRS Chapter 344, provides that during the performance of this contract, the contractor agrees as follows:

1. The contractor shall not fail or refuse to hire, or shall not discharge any individual, or otherwise discriminate against an individual with respect to his compensation, terms, conditions, or privileges of employment, because of such individual's race, color, religion, national origin, sex, disability or age (forty and above); or limit, segregate, or classify his employees in any way which would deprive or tend to deprive an individual of employment opportunities or otherwise adversely affect his status as an employee, because of such individual's race, color, religion, national origin, sex, disability or age forty (40) and over. The contractor agrees to post in conspicuous places, available to employees and applicants for employment, notices to be provided setting forth the provisions of this nondiscrimination clause.

2. The contractor shall not print or publish or cause to be printed or published a notice or advertisement relating to employment by such an employer or membership in or any classification or referral for employment by the employment agency, indicating any preference, limitation, specification, or discrimination, based on race, color, religion, national origin, sex, or age forty (40) and over, or because the person is a qualified individual with a disability, except that such a notice or advertisement may indicate a preference, limitation, or specification based on religion, national origin, sex, or age forty (40) and over, or because the person is a qualified individual with a disability, when religion, national origin, sex, or age forty (40) and over, or because the person is a qualified individual with a disability, is a bona fide occupational qualification for employment.

3. If the contractor is in control of apprenticeship or other training or retraining, including on-the-job training programs, he shall not discriminate against an individual because of his race, color, religion, national origin, sex, disability or age forty (40) and over, in admission to, or employment in any program established to provide apprenticeship or other training.

4. The contractor will send to each labor union or representative of workers with which he has a collective bargaining agreement or other contract or understanding, a notice to be provided advising the said labor union or workers' representative of the contractor's commitments under this section, and shall post copies of the notice in conspicuous places available to employees and applicants for employment. The contractor will take such action with respect to any subcontract or purchase order as the administering agency may direct as a means of enforcing such provisions, including sanctions for non-compliance.

Revised: January 25, 2017

### Standard Title VI/Non-Discrimination Assurances

During the performance of this contract, the contractor, for itself, its assignees, and successors in interest (hereinafter referred to as the "contractor") agrees as follows:

1. **Compliance with Regulations:** The contractor (hereinafter includes consultants) will comply with the Acts and the Regulations relative to Non-discrimination in Federally-assisted programs of the U.S. Department of Transportation, **Federal Highway Administration**, as they may be amended from time to time, which are herein incorporated by reference and made a part of this contract.
2. **Non-discrimination:** The contractor, with regard to the work performed by it during the contract, will not discriminate on the grounds of race, color, or national origin in the selection and retention of subcontractors, including procurements of materials and leases of equipment. The contractor will not participate directly or indirectly in the discrimination prohibited by the Acts and the Regulations, including employment practices when the contract covers any activity, project, or program set forth in Appendix B of 49 CFR Part 21.
3. **Solicitations for Subcontracts, Including Procurements of Materials and Equipment:** In all solicitations, either by competitive bidding, or negotiation made by the contractor for work to be performed under a subcontract, including procurements of materials, or leases of equipment, each potential subcontractor or supplier will be notified by the contractor of the contractor's obligations under this contract and the Acts and the Regulations relative to Non-discrimination on the grounds of race, color, or national origin.
4. **Information and Reports:** The contractor will provide all information and reports required by the Acts, the Regulations, and directives issued pursuant thereto and will permit access to its books, records, accounts, other sources of information, and its facilities as may be determined by the Recipient or the **Federal Highway Administration** to be pertinent to ascertain compliance with such Acts, Regulations, and instructions. Where any information required of a contractor is in the exclusive possession of another who fails or refuses to furnish the information, the contractor will so certify to the Recipient or the **Federal Highway Administration**, as appropriate, and will set forth what efforts it has made to obtain the information.
5. **Sanctions for Noncompliance:** In the event of a contractor's noncompliance with the Non-discrimination provisions of this contract, the Recipient will impose such contract sanctions as it or the **Federal Highway Administration** may determine to be appropriate, including, but not limited to:
  - a. withholding payments to the contractor under the contract until the contractor complies; and/or
  - b. cancelling, terminating, or suspending a contract, in whole or in part.
6. **Incorporation of Provisions:** The contractor will include the provisions of paragraphs one through six in every subcontract, including procurements of materials and leases of equipment, unless exempt by the Acts, the Regulations and directives issued pursuant thereto. The contractor will take action with respect to any subcontract or procurement as the Recipient or the **Federal Highway Administration** may direct as a means of enforcing such provisions including sanctions for noncompliance. Provided, that if the contractor becomes involved in, or is threatened with litigation by a subcontractor, or supplier because of such direction, the contractor may request the Recipient to enter into any litigation to protect the interests of the Recipient. In addition, the contractor may request the United States to enter into the litigation to protect the interests of the United States.

### Standard Title VI/Non-Discrimination Statutes and Authorities

During the performance of this contract, the contractor, for itself, its assignees, and successors in interest (hereinafter referred to as the “contractor”) agrees to comply with the following non-discrimination statutes and authorities; including but not limited to:

- Title VI of the Civil Rights Act of 1964 (42 U.S.C. § 2000d *et seq.*, 78 stat. 252), (prohibits discrimination on the basis of race, color, national origin); and 49 CFR Part 21;
- The Uniform Relocation Assistance and Real Property Acquisition Policies Act of 1970, (42 U.S.C. § 4601), (prohibits unfair treatment of persons displaced or whose property has been acquired because of Federal or Federal-aid programs and projects);
- Federal-Aid Highway Act of 1973, (23 U.S.C. § 324 *et seq.*), (prohibits discrimination on the basis of sex);
- Section 504 of the Rehabilitation Act of 1973, (29 U.S.C. § 794 *et seq.*), as amended, (prohibits discrimination on the basis of disability); and 49 CFR Part 27;
- The Age Discrimination Act of 1975, as amended, (42 U.S.C. § 6101 *et seq.*), (prohibits discrimination on the basis of age);
- Airport and Airway Improvement Act of 1982, (49 USC § 471, Section 47123), as amended, (prohibits discrimination based on race, creed, color, national origin, or sex);
- The Civil Rights Restoration Act of 1987, (PL 100-209), (Broadened the scope, coverage and applicability of Title VI of the Civil Rights Act of 1964, The Age Discrimination Act of 1975 and Section 504 of the Rehabilitation Act of 1973, by expanding the definition of the terms “programs or activities” to include all of the programs or activities of the Federal-aid recipients, sub-recipients and contractors, whether such programs or activities are Federally funded or not);
- Titles II and III of the Americans with Disabilities Act, which prohibit discrimination on the basis of disability in the operation of public entities, public and private transportation systems, places of public accommodation, and certain testing entities (42 U.S.C. §§ 12131 -- 12189) as implemented by Department of Transportation regulations at 49 C.F.R. parts 37 and 38;
- The Federal Aviation Administration’s Non-discrimination statute (49 U.S.C. § 47123) (prohibits discrimination on the basis of race, color, national origin, and sex);
- Executive Order 12898, Federal Actions to Address Environmental Justice in Minority Populations and Low-Income Populations, which ensures non-discrimination against minority populations by discouraging programs, policies, and activities with disproportionately high and adverse human health or environmental effects on minority and low-income populations;
- Executive Order 13166, Improving Access to Services for Persons with Limited English Proficiency, and resulting agency guidance, national origin discrimination includes discrimination because of limited English proficiency (LEP). To ensure compliance with Title VI, you must take reasonable steps to ensure that LEP persons have meaningful access to your programs (70 Fed. Reg. at 74087 to 74100);
- Title IX of the Education Amendments of 1972, as amended, which prohibits you from discriminating because of sex in education programs or activities (20 U.S.C. 1681 *et seq.*)

## EXECUTIVE BRANCH CODE OF ETHICS

In the 1992 regular legislative session, the General Assembly passed and Governor Brereton Jones signed Senate Bill 63 (codified as KRS 11A), the Executive Branch Code of Ethics, which states, in part:

KRS 11A.040 (7) provides:

No present or former public servant shall, within six (6) months following termination of his office or employment, accept employment, compensation, or other economic benefit from any person or business that contracts or does business with, or is regulated by, the state in matters in which he was directly involved during the last thirty-six (36) months of his tenure. This provision shall not prohibit an individual from returning to the same business, firm, occupation, or profession in which he was involved prior to taking office or beginning his term of employment, or for which he received, prior to his state employment, a professional degree or license, provided that, for a period of six (6) months, he personally refrains from working on any matter in which he was directly involved during the last thirty-six (36) months of his tenure in state government. This subsection shall not prohibit the performance of ministerial functions, including but not limited to filing tax returns, filing applications for permits or licenses, or filing incorporation papers, nor shall it prohibit the former officer or public servant from receiving public funds disbursed through entitlement programs.

KRS 11A.040 (9) states:

A former public servant shall not represent a person or business before a state agency in a matter in which the former public servant was directly involved during the last thirty-six (36) months of his tenure, for a period of one (1) year after the latter of:

- a) The date of leaving office or termination of employment; or
- b) The date the term of office expires to which the public servant was elected.

This law is intended to promote public confidence in the integrity of state government and to declare as public policy the idea that state employees should view their work as a public trust and not as a way to obtain private benefits.

If you have worked for the executive branch of state government within the past six months, you may be subject to the law's prohibitions. The law's applicability may be different if you hold elected office or are contemplating representation of another before a state agency.

Also, if you are affiliated with a firm which does business with the state and which employs former state executive-branch employees, you should be aware that the law may apply to them.

In case of doubt, the law permits you to request an advisory opinion from the Executive Branch Ethics Commission, 3 Fountain Place, Frankfort, Kentucky 40601; telephone (502) 564-7954.

Revised: January 27, 2017

"General Decision Number: KY20200040 11/06/2020

Superseded General Decision Number: KY20190040

State: Kentucky

Construction Type: Highway

Counties: Allen, Ballard, Butler, Caldwell, Calloway, Carlisle, Christian, Crittenden, Daviess, Edmonson, Fulton, Graves, Hancock, Henderson, Hickman, Hopkins, Livingston, Logan, Lyon, Marshall, McCracken, McLean, Muhlenberg, Ohio, Simpson, Todd, Trigg, Union, Warren and Webster Counties in Kentucky.

HIGHWAY CONSTRUCTION PROJECTS (excluding tunnels, building structures in rest area projects & railroad construction; bascule, suspension & spandrel arch bridges designed for commercial navigation, bridges involving marine construction; and other major bridges).

Note: Under Executive Order (EO) 13658, an hourly minimum wage of \$10.80 for calendar year 2020 applies to all contracts subject to the Davis-Bacon Act for which the contract is awarded (and any solicitation was issued) on or after January 1, 2015. If this contract is covered by the EO, the contractor must pay all workers in any classification listed on this wage determination at least \$10.80 per hour (or the applicable wage rate listed on this wage determination, if it is higher) for all hours spent performing on the contract in calendar year 2020. If this contract is covered by the EO and a classification considered necessary for performance of work on the contract does not appear on this wage determination, the contractor must pay workers in that classification at least the wage rate determined through the conformance process set forth in 29 CFR 5.5(a)(1)(ii) (or the EO minimum wage rate, if it is higher than the conformed wage rate). The EO minimum wage rate will be adjusted annually. Please note that this EO applies to the above-mentioned types of contracts entered into by the federal government that are subject to the Davis-Bacon Act itself, but it does not apply to contracts subject only to the Davis-Bacon Related Acts, including those set forth at 29 CFR 5.1(a)(2)-(60). Additional information on contractor requirements and worker protections under the EO is available at [www.dol.gov/whd/govcontracts](http://www.dol.gov/whd/govcontracts).

Modification Number	Publication Date
0	01/03/2020
1	01/10/2020
2	01/31/2020
3	08/14/2020
4	08/28/2020
5	10/02/2020
6	10/23/2020
7	10/30/2020
8	11/06/2020

BRIN0004-002 06/01/2017

BALLARD, BUTLER, CALDWELL, CARLISLE, CRITTENDEN, DAVIESS, EDMONSON, FULTON, GRAVES, HANCOCK, HENDERSON, HICKMAN, HOPKINS, LIVINGSTON, LYON, MARSHALL, MCCRACKEN, MCLEAN,

MUHLENBERG, OHIO, UNION, and WEBSTER COUNTIES

	Rates	Fringes
BRICKLAYER		
Ballard, Caldwell, Carlisle, Crittenden, Fulton, Graves, Hickman, Livingston, Lyon, Marshall, and McCracken Counties.....	\$ 30.50	15.16
Butler, Edmonson, Hopkins, Muhlenberg, and Ohio Counties.....	\$ 26.80	12.38
Daviess, Hancock, Henderson, McLean, Union, and Webster Counties.....	\$ 30.00	15.16

-----  
BRTN0004-005 06/01/2017

ALLEN, CALLOWAY, CHRISTIAN, LOGAN, SIMPSON, TODD, TRIGG, and  
WARREN COUNTIES

	Rates	Fringes
BRICKLAYER.....	\$ 26.80	12.38

-----  
\* CARP0357-002 04/01/2020

	Rates	Fringes
CARPENTER.....	\$ 29.81	19.92
DIVER.....	\$ 45.09	19.92
PILEDRIVERMAN.....	\$ 30.06	19.92

-----  
ELEC0369-006 05/28/2019

BUTLER, EDMONSON, LOGAN, TODD & WARREN COUNTIES:

	Rates	Fringes
ELECTRICIAN.....	\$ 32.44	17.22

-----  
ELEC0429-001 01/01/2020

ALLEN & SIMPSON COUNTIES:

	Rates	Fringes
ELECTRICIAN.....	\$ 27.72	13.48

-----  
ELEC0816-002 06/30/2020

BALLARD, CALDWELL, CALLOWAY, CARLISLE, CHRISTIAN, CRITTENDEN,  
FULTON (Except a 5 mile radius of City Hall in Fulton), GRAVES,  
HICKMAN, LIVINGSTON, LYON, MARSHALL, MCCRACKEN & TRIGG COUNTIES:

	Rates	Fringes
ELECTRICIAN.....	\$ 34.06	25.50%+7.25

Cable spicers receive \$.25 per hour additional.

-----

ELEC1701-003 01/01/2020

DAVISS, HANCOCK, HENDERSON, HOPKINS, MCLEAN, MUHLENBERG, OHIO,  
UNION & WEBSTER COUNTIES:

	Rates	Fringes
ELECTRICIAN.....	\$ 31.52	30%+7.25

Cable spicers receive \$.25 per hour additional.

-----

ELEC1925-002 01/01/2020

FULTON COUNTY (Up to a 5 mile radius of City Hall in Fulton):

	Rates	Fringes
CABLE SPLICER.....	\$ 25.60	14.50
ELECTRICIAN.....	\$ 25.10	14.48

-----

ENGI0181-017 07/01/2020

	Rates	Fringes
POWER EQUIPMENT OPERATOR		
GROUP 1.....	\$ 33.95	17.25
GROUP 2.....	\$ 31.09	17.25
GROUP 3.....	\$ 31.54	17.25
GROUP 4.....	\$ 30.77	17.25

OPERATING ENGINEER CLASSIFICATIONS

GROUP 1 - A-Frame Winch Truck; Auto Patrol; Backfiller; Batcher Plant; Bituminous Paver; Bituminous Transfer Machine; Boom Cat; Bulldozer; Mechanic; Cableway; Carry-All Scoop; Carry Deck Crane; Central Compressor Plant; Cherry Picker; Clamshell; Concrete Mixer (21 cu. ft. or Over); Concrete Paver; Truck-Mounted Concrete Pump; Core Drill; Crane; Crusher Plant; Derrick; Derrick Boat; Ditching & Trenching Machine; Dragline; Dredge Operator; Dredge Engineer; Elevating Grader & Loaders; Grade-All; Gurries; Heavy Equipment Robotics Operator/Mechanic; High Lift; Hoe-Type Machine; Hoist (Two or More Drums); Hoisting Engine (Two or More Drums); Horizontal Directional Drill Operator; Hydrocrane; Hyster; KeCal Loader; LeTourneau; Locomotive; Mechanic; Mechanically Operated Laser Screed; Mechanic Welder; Mucking Machine; Motor Scraper; Orangepeel Bucket; Overhead Crane; Piledriver; Power Blade; Pumpcrete; Push Dozer; Rock Spreader, attached to equipment; Rotary Drill; Roller (Bituminous); Rough Terrain Crane; Scarifier; Scoopmobile; Shovel; Side Boom; Subgrader; Tailboom; Telescoping Type Forklift; Tow or Push Boat; Tower Crane (French, German & other types); Tractor Shovel; Truck Crane; Tunnel Mining Machines, including Moles, Shields or similar types of Tunnel Mining Equipment

GROUP 2 - Air Compressor (Over 900 cu. ft. per min.); Bituminous Mixer; Boom Type Tamping Machine; Bull Float; Concrete Mixer (Under 21 cu. ft.); Dredge Engineer; Electric Vibrator; Compactor/Self-Propelled Compactor; Elevator (One Drum or Buck Hoist); Elevator (When used to

Hoist Building Material); Finish Machine; Firemen & Hoist (One Drum); Flexplane; Forklift (Regardless of Lift Height); Form Grader; Joint Sealing Machine; Outboard Motor Boat; Power Sweeper (Riding Type); Roller (Rock); Ross Carrier; Skid Mounted or Trailer Mounted Concrete Pump; Skid Steer Machine with all Attachments; Switchman or Brakeman; Throttle Valve Person; Tractair & Road Widening Trencher; Tractor (50 H.P. or Over); Truck Crane Oiler; Tugger; Welding Machine; Well Points;& Whirley Oiler

GROUP 3 -All Off Road Material Handling Equipment, including Articulating Dump Trucks; Greaser on Grease Facilities servicing Heavy Equipment

GROUP 4 - Bituminous Distributor; Burlap & Curing Machine; Cement Gun; Concrete Saw; Conveyor; Deckhand Oiler; Grout Pump; Hydraulic Post Driver; Hydro Seeder; Mud Jack; Oiler; Paving Joint Machine; Power Form Handling Equipment; Pump; Roller (Earth); Steerman; Tamping Machine; Tractor (Under 50 H.P.); & Vibrator

CRANES - with booms 150 ft. & Over (Including JIB), and where the length of the boom in combination with the length of the piling equals or exceeds 150 ft. - \$1.00 above Group 1 rate

EMPLOYEES ASSIGNED TO WORK BELOW GROUND LEVEL ARE TO BE PAID 10% ABOVE BASIC WAGE RATE. THIS DOES NOT APPLY TO OPEN CUT WORK.

-----  
IRON0070-005 06/01/2020

BUTLER COUNTY (Eastern eighth, including the Townships of Decker, Lee & Tilford);  
EDMONSON COUNTY (Northern three-fourths, including the Townships of Asphalt, Bee Spring, Brownsville, Grassland, Huff, Kyrock, Lindseyville, Mammoth Cave, Ollie, Prosperity, Rhoda, Sunfish & Sweden)

Rates Fringes

IRONWORKER

Structural; Ornamental;  
Reinforcing; Precast  
Concrete Erectors.....\$ 30.42 23.15

-----  
IRON0103-004 08/01/2018

DAVISS, HANCOCK, HENDERSON, HOPKINS, MCLEAN, OHIO, UNION & WEBSTER COUNTIES  
BUTLER COUNTY (Townships of Aberdeen, Bancock, Casey, Dexterville, Dunbar, Elfie, Gilstrap, Huntsville, Logansport, Monford, Morgantown, Provo, Rochester, South Hill & Welchs Creek);  
CALDWELL COUNTY (Northeastern third, including the Township of Creswell);  
CHRISTIAN COUNTY (Northern third, including the Townships of Apex, Crofton, Kelly, Mannington & Wynns);  
CRITTENDEN COUNTY (Northeastern half, including the Townships of Grove, Mattoon, Repton, Shady Grove & Tribune);  
MUHLENBERG COUNTY (Townships of Bavier, Beech Creek Junction, Benton, Brennen, Browder, Central City, Cleaton, Depoy,

Drakesboro, Eunis, Graham, Hillside, Luzerne, Lynn City,  
 Martwick, McNary, Millport, Moorman, Nelson, Paradise,  
 Powderly, South Carrollton, Tarina & Weir)

	Rates	Fringes
Ironworkers:.....	\$ 28.66	22.435
-----		
IRON0492-003 05/01/2018		

ALLEN, LOGAN, SIMPSON, TODD & WARREN COUNTIES  
 BUTLER COUNTY (Southern third, including the Townships of  
 Boston, Berrys Lick, Dimple, Jetson, Quality, Sharer, Sugar  
 Grove & Woodbury);  
 CHRISTIAN COUNTY (Eastern two-thirds, including the Townships  
 of Bennettstown, Casky, Herndon, Hopkinsville, Howell,  
 Masonville, Pembroke & Thompsonville);  
 EDMONSON COUNTY (Southern fourth, including the Townships of  
 Chalybeate & Rocky Hill);  
 MUHLENBERG COUNTY (Southern eighth, including the Townships of  
 Dunnior, Penrod & Rosewood)

	Rates	Fringes
Ironworkers:.....	\$ 26.11	14.02
-----		
IRON0782-006 05/01/2018		

BALLARD, CALLOWAY, CARLISLE, FULTON, GRAVES, HICKMAN,  
 LIVINGSTON, LYON, MARSHALL, MCCRACKEN & TRIGG COUNTIES  
 CALDWELL COUNTY (Southwestern two-thirds, including the  
 Townships of Cedar Bluff, Cider, Claxton, Cobb, Crowtown,  
 Dulaney, Farmersville, Fredonia, McGowan, Otter Pond &  
 Princeton);  
 CHRISTIAN COUNTY (Western third, Excluding the Townships of  
 Apex, Crofton, Kelly, Mannington, Wynns, Bennettstown, Casky,  
 Herndon, Hopkinsville, Howell, Masonville, Pembroke &  
 Thompsonville);  
 CRITTENDEN COUNTY (Southwestern half, including the Townships  
 of Crayne, Dycusburg, Frances, Marion, Mexico, Midway,  
 Sheridan & Told)

	Rates	Fringes
Ironworkers:		
Projects with a total contract cost of \$20,000,000.00 or above.....	\$ 28.79	24.17
All Other Work.....	\$ 27.20	22.75
-----		
LABO0189-005 07/01/2020		

BALLARD, CALLOWAY, CARLISLE, FULTON, GRAVES, HICKMAN,  
 LIVINGSTON, LYON, MARSHALL & MCCRACKEN COUNTIES

	Rates	Fringes
Laborers:		
GROUP 1.....	\$ 23.26	15.62
GROUP 2.....	\$ 23.51	15.62

GROUP 3.....	\$ 23.56	15.62
GROUP 4.....	\$ 24.16	15.62

LABORER CLASSIFICATIONS

GROUP 1 - Aging & Curing of Concrete; Asbestos Abatement Worker; Asphalt Plant; Asphalt; Batch Truck Dump; Carpenter Tender; Cement Mason Tender; Cleaning of Machines; Concrete; Demolition; Dredging; Environmental - Nuclear, Radiation, Toxic & Hazardous Waste - Level D; Flagperson; Grade Checker; Hand Digging & Hand Back Filling; Highway Marker Placer; Landscaping, Mesh Handler & Placer; Puddler; Railroad; Rip-rap & Grouter; Right-of-Way; Sign, Guard Rail & Fence Installer; Signal Person; Sound Barrier Installer; Storm & Sanitary Sewer; Swamper; Truck Spotter & Dumper; Wrecking of Concrete Forms; General Cleanup

GROUP 2 - Batter Board Man (Sanitary & Storm Sewer); Brickmason Tender; Mortar Mixer Operator; Scaffold Builder; Burner & Welder; Bushhammer; Chain Saw Operator; Concrete Saw Operator; Deckhand Scow Man; Dry Cement Handler; Environmental - Nuclear, Radiation, Toxic & Hazardous Waste - Level C; Forklift Operator for Masonary; Form Setter; Green Concrete Cutting; Hand Operated Grouter & Grinder Machine Operator; Jackhammer; Pavement Breaker; Paving Joint Machine; Pipelayer; Plastic Pipe Fusion; Power Driven Georgia Buggy & Wheel Barrow; Power Post Hole Digger; Precast Manhole Setter; Walk-Behind Tamper; Walk-Behind Trencher; Sand Blaster; Concrete Chipper; Surface Grinder; Vibrator Operator; Wagon Driller

GROUP 3 - Asphalt Luteman & Raker; Gunnite Nozzleman; Gunnite Operator & Mixer; Grout Pump Operator; Blaster; Side Rail Setter; Rail Paved Ditches; Screw Operator; Tunnel (Free Air); Water Blaster

GROUP 4 - Caisson Worker (Free Air); Cement Finisher; Environmental - Nuclear, Radiation, Toxic & Hazardous Waste - Levels A & B; Miner & Driller (Free Air); Tunnel Blaster; & Tunnel Mucker (Free Air); Directional & Horizontal Boring; Air Track Drillers (All Types); Powdermen & Blasters; Troxler & Concrete Tester if Laborer is Utilized

-----  
 LABO0189-006 07/01/2020

ALLEN, BUTLER, CALDWELL, CHRISTIAN, DAVIESS, EDMONSON, HANCOCK, HOPKINS, LOGAN, MCLEAN, MUHLENBERG, OHIO, SIMPSON, TODD, TRIGG & WARREN COUNTIES

	Rates	Fringes
Laborers:		
GROUP 1.....	\$ 23.26	15.62
GROUP 2.....	\$ 23.51	15.62
GROUP 3.....	\$ 23.56	15.62
GROUP 4.....	\$ 24.16	15.62

LABORER CLASSIFICATIONS

GROUP 1 - Aging & Curing of Concrete; Asbestos Abatement Worker; Asphalt Plant; Asphalt; Batch Truck Dump; Carpenter Tender; Cement Mason Tender; Cleaning of Machines;

Concrete; Demolition; Dredging; Environmental - Nuclear, Radiation, Toxic & Hazardous Waste - Level D; Flagperson; Grade Checker; Hand Digging & Hand Back Filling; Highway Marker Placer; Landscaping, Mesh Handler & Placer; Puddler; Railroad; Rip-rap & Grouter; Right-of-Way; Sign, Guard Rail & Fence Installer; Signal Person; Sound Barrier Installer; Storm & Sanitary Sewer; Swamper; Truck Spotter & Dumper; Wrecking of Concrete Forms; General Cleanup

GROUP 2 - Batter Board Man (Sanitary & Storm Sewer); Brickmason Tender; Mortar Mixer Operator; Scaffold Builder; Burner & Welder; Bushhammer; Chain Saw Operator; Concrete Saw Operator; Deckhand Scow Man; Dry Cement Handler; Environmental - Nuclear, Radiation, Toxic & Hazardous Waste - Level C; Forklift Operator for Masonary; Form Setter; Green Concrete Cutting; Hand Operated Grouter & Grinder Machine Operator; Jackhammer; Pavement Breaker; Paving Joint Machine; Pipelayer; Plastic Pipe Fusion; Power Driven Georgia Buggy & Wheel Barrow; Power Post Hole Digger; Precast Manhole Setter; Walk-Behind Tamper; Walk-Behind Trencher; Sand Blaster; Concrete Chipper; Surface Grinder; Vibrator Operator; Wagon Driller

GROUP 3 - Asphalt Luteman & Raker; Gunnite Nozzleman; Gunnite Operator & Mixer; Grout Pump Operator; Blaster; Side Rail Setter; Rail Paved Ditches; Screw Operator; Tunnel (Free Air); Water Blaster

GROUP 4 - Caisson Worker (Free Air); Cement Finisher; Environmental - Nuclear, Radiation, Toxic & Hazardous Waste - Levels A & B; Miner & Driller (Free Air); Tunnel Blaster; & Tunnel Mucker (Free Air); Directional & Horizontal Boring; Air Track Drillers (All Types); Powdermen & Blasters; Troxler & Concrete Tester if Laborer is Utilized

-----  
LABO0561-001 07/01/2020

CRITTENDEN, HENDERSON, UNION & WEBSTER COUNTIES

	Rates	Fringes
Laborers:		
GROUP 1.....	\$ 23.66	16.10
GROUP 2.....	\$ 23.91	16.10
GROUP 3.....	\$ 23.96	16.10
GROUP 4.....	\$ 24.56	16.10

LABORER CLASSIFICATIONS

GROUP 1 - Aging & Curing of Concrete; Asbestos Abatement Worker; Asphalt Plant; Asphalt; Batch Truck Dump; Carpenter Tender; Cement Mason Tender; Cleaning of Machines; Concrete; Demolition; Dredging; Environmental - Nuclear, Radiation, Toxic & Hazardous Waste - Level D; Flagperson; Grade Checker; Hand Digging & Hand Back Filling; Highway Marker Placer; Landscaping, Mesh Handler & Placer; Puddler; Railroad; Rip-rap & Grouter; Right-of-Way; Sign, Guard Rail & Fence Installer; Signal Person; Sound Barrier Installer; Storm & Sanitary Sewer; Swamper; Truck Spotter & Dumper; Wrecking of Concrete Forms; General Cleanup

GROUP 2 - Batter Board Man (Sanitary & Storm Sewer); Brickmason Tender; Mortar Mixer Operator; Scaffold Builder;

Burner & Welder; Bushhammer; Chain Saw Operator; Concrete Saw Operator; Deckhand Scow Man; Dry Cement Handler; Environmental - Nuclear, Radiation, Toxic & Hazardous Waste - Level C; Forklift Operator for Masonary; Form Setter; Green Concrete Cutting; Hand Operated Grouter & Grinder Machine Operator; Jackhammer; Pavement Breaker; Paving Joint Machine; Pipelayer; Plastic Pipe Fusion; Power Driven Georgia Buggy & Wheel Barrow; Power Post Hole Digger; Precast Manhole Setter; Walk-Behind Tamper; Walk-Behind Trencher; Sand Blaster; Concrete Chipper; Surface Grinder; Vibrator Operator; Wagon Driller

GROUP 3 - Asphalt Luteman & Raker; Gunnite Nozzleman; Gunnite Operator & Mixer; Grout Pump Operator; Blaster; Side Rail Setter; Rail Paved Ditches; Screw Operator; Tunnel (Free Air); Water Blaster

GROUP 4 - Caisson Worker (Free Air); Cement Finisher; Environmental - Nuclear, Radiation, Toxic & Hazardous Waste - Levels A & B; Miner & Driller (Free Air); Tunnel Blaster; & Tunnel Mucker (Free Air); Directional & Horizontal Boring; Air Track Drillers (All Types); Powdermen & Blasters; Troxler & Concrete Tester if Laborer is Utilized

-----  
PAIN0032-002 09/01/2020

BALLARD COUNTY

	Rates	Fringes
Painters:		
Bridges.....	\$ 35.01	17.93
All Other Work.....	\$ 32.71	17.93
Spray, Blast, Steam, High & Hazardous (Including Lead Abatement) and All Epoxy - \$1.00 Premium		

-----  
PAIN0118-003 06/01/2014

EDMONSON COUNTY:

	Rates	Fringes
Painters:		
Brush & Roller.....	\$ 18.50	11.97
Spray, Sandblast, Power Tools, Waterblast & Steam Cleaning.....	\$ 19.50	11.97

-----  
PAIN0156-006 04/01/2015

DAVISS, HANCOCK, HENDERSON, MCLEAN, OHIO, UNION & WEBSTER COUNTIES

	Rates	Fringes
Painters:		
BRIDGES		
GROUP 1.....	\$ 27.60	12.85
GROUP 2.....	\$ 27.85	12.85
GROUP 3.....	\$ 28.60	12.85

GROUP 4.....	\$ 29.60	12.85
ALL OTHER WORK:		
GROUP 1.....	\$ 26.45	12.85
GROUP 2.....	\$ 26.70	12.85
GROUP 3.....	\$ 27.45	12.85
GROUP 4.....	\$ 28.45	12.85

PAINTER CLASSIFICATIONS

GROUP 1 - Brush & Roller

GROUP 2 - Plasterers

GROUP 3 - Spray; Sandblast; Power Tools; Waterblast;  
Steamcleaning; Brush & Roller of Mastics, Creosotes, Kwinch  
Koate & Coal Tar Epoxy

GROUP 4 - Spray of Mastics, Creosotes, Kwinch Koate & Coal  
Tar Epoxy

-----  
PAIN0500-002 06/01/2020

CALDWELL, CALLOWAY, CARLISLE, CHRISTIAN, CRITTENDEN, FULTON,  
GRAVES, HICKMAN, HOPKINS, LIVINGSTON, LYON, MARSHALL, MCCRACKEN  
& TRIGG COUNTIES:

	Rates	Fringes
Painters:		
Bridges.....	\$ 27.75	15.10
All Other Work.....	\$ 21.50	15.10

Waterblasting units with 3500 PSI and above - \$.50 premium  
Spraypainting and all abrasive blasting - \$1.00 premium  
Work 40 ft. and above ground level - \$1.00 premium

-----  
PLUM0184-002 07/01/2018

BALLARD, CALDWELL, CALLOWAY, CARLISLE, CHRISTIAN, CRITTENDEN,  
FULTON, GRAVES, HICKMAN, LIVINGSTON, LYON, MARSHALL, MCCRACKEN  
and TRIGG COUNTIES

	Rates	Fringes
Plumber; Steamfitter.....	\$ 35.06	18.18

-----  
PLUM0502-004 08/01/2020

ALLEN, BUTLER, EDMONSON, SIMPSON & WARREN

	Rates	Fringes
Plumber; Steamfitter.....	\$ 36.92	20.78

-----  
PLUM0633-002 07/01/2020

DAVISS, HANCOCK, HENDERSON, HOPKINS, LOGAN, MCLEAN,  
MUHLENBERG, OHIO, TODD, UNION & WEBSTER COUNTIES:

	Rates	Fringes
PLUMBER/PIPEFITTER.....	\$ 32.17	19.30

-----  
\* TEAM0089-003 04/01/2020

ALLEN, BUTLER, EDMONSON, LOGAN, SIMPSON & WARREN COUNTIES

	Rates	Fringes
Truck drivers:		
Zone 1:		
Group 1.....	\$ 20.82	23.49
Group 2.....	\$ 21.00	23.49
Group 3.....	\$ 21.08	23.49
Group 4.....	\$ 21.10	23.49

GROUP 1 - Greaser; Tire Changer

GROUP 2 - Truck Mechanic; Single Axle Dump; Flat Bed; All Terrain Vehicles when used to haul materials; Semi Trailer or Pole Trailer when used to pull building materials and equipment; Tandem Axle Dump; Driver of Distributors

GROUP 3 - Mixer All Types

GROUP 4 - Winch and A-Frame when used in transporting materials; Ross Carrier; Fork Lift when used to transport building materials; Driver on Pavement Breaker; Euclid and Other Heavy Earth Moving Equipment; Low Boy; Articulator Cat; Five Axle Vehicle

-----  
\* TEAM0215-003 04/01/2020

DAVISS, HANCOCK, HENDERSON, HOPKINS, MCLEAN, MUHLENBERG, OHIO & WEBSTER COUNTIES

	Rates	Fringes
TRUCK DRIVER		
Group 1.....	\$ 22.45	23.49
Group 2.....	\$ 22.68	23.49
Group 3.....	\$ 22.75	23.49
Group 4.....	\$ 22.76	23.49

GROUP 1: Greaser, Tire Changer

GROUP 2: Truck Mechanic

GROUP 3: Single Axle Dump; Flat Bed; All Terrain Vehicle when used to haul materials; Semi Trailer or Pole Trailer when used to pull building materials and equipment; Tandem Axle Dump; Driver of Distributors; Mixer All Types

GROUP 4: Euclid and other heavy earth moving equipment; Low Boy; Articulator Cat; 5 Axle Vehicle; Winch and A- Frame when used in transporting materials; Ross Carrier; Fork Lift when used to transport building materials; Driver on Pavement Breaker

-----  
\* TEAM0236-001 04/01/2020

BALLARD, CALDWELL, CALLOWAY, CARLISLE, CHRISTIAN, CRITTENDEN,  
FULTON, GRAVES, HICKMAN, LIVINGSTON, LYON, MARSHALL,  
MCCRACKEN, TODD & TRIGG COUNTIES

	Rates	Fringes
TRUCK DRIVER		
Group 1.....	\$ 20.82	23.49
Group 2.....	\$ 21.00	23.49
Group 3.....	\$ 21.00	23.49
Group 4.....	\$ 21.00	23.49
Group 5.....	\$ 21.08	23.49

GROUP 1: Greaser, Tire Changer

GROUP 2: Truck Mechanic

GROUP 3: Single Axle Dump; Flat Bed; All Terrain Vehicle when used to haul materials; Semi Trailer or Pole Trailer when used to pull building materials and equipment; Tandem Axle Dump; Drivers of Distributors

GROUP 4: Euclid and other heavy earth moving equipment; Low Boy; Articulator Cat; Five Axle Vehicle; Winch and A-Frame when used in transporting materials; Ross Carrier

GROUP 5: Mixer All Types

-----  
WELDERS - Receive rate prescribed for craft performing operation to which welding is incidental.

=====  
Note: Executive Order (EO) 13706, Establishing Paid Sick Leave for Federal Contractors applies to all contracts subject to the Davis-Bacon Act for which the contract is awarded (and any solicitation was issued) on or after January 1, 2017. If this contract is covered by the EO, the contractor must provide employees with 1 hour of paid sick leave for every 30 hours they work, up to 56 hours of paid sick leave each year. Employees must be permitted to use paid sick leave for their own illness, injury or other health-related needs, including preventive care; to assist a family member (or person who is like family to the employee) who is ill, injured, or has other health-related needs, including preventive care; or for reasons resulting from, or to assist a family member (or person who is like family to the employee) who is a victim of, domestic violence, sexual assault, or stalking. Additional information on contractor requirements and worker protections under the EO is available at [www.dol.gov/whd/govcontracts](http://www.dol.gov/whd/govcontracts).

Unlisted classifications needed for work not included within the scope of the classifications listed may be added after award only as provided in the labor standards contract clauses (29CFR 5.5 (a) (1) (ii)).

The body of each wage determination lists the classification and wage rates that have been found to be prevailing for the cited type(s) of construction in the area covered by the wage determination. The classifications are listed in alphabetical order of ""identifiers"" that indicate whether the particular rate is a union rate (current union negotiated rate for local), a survey rate (weighted average rate) or a union average rate (weighted union average rate).

#### Union Rate Identifiers

A four letter classification abbreviation identifier enclosed in dotted lines beginning with characters other than ""SU"" or ""UAVG"" denotes that the union classification and rate were prevailing for that classification in the survey. Example: PLUM0198-005 07/01/2014. PLUM is an abbreviation identifier of the union which prevailed in the survey for this classification, which in this example would be Plumbers. 0198 indicates the local union number or district council number where applicable, i.e., Plumbers Local 0198. The next number, 005 in the example, is an internal number used in processing the wage determination. 07/01/2014 is the effective date of the most current negotiated rate, which in this example is July 1, 2014.

Union prevailing wage rates are updated to reflect all rate changes in the collective bargaining agreement (CBA) governing this classification and rate.

#### Survey Rate Identifiers

Classifications listed under the ""SU"" identifier indicate that no one rate prevailed for this classification in the survey and the published rate is derived by computing a weighted average rate based on all the rates reported in the survey for that classification. As this weighted average rate includes all rates reported in the survey, it may include both union and non-union rates. Example: SULA2012-007 5/13/2014. SU indicates the rates are survey rates based on a weighted average calculation of rates and are not majority rates. LA indicates the State of Louisiana. 2012 is the year of survey on which these classifications and rates are based. The next number, 007 in the example, is an internal number used in producing the wage determination. 5/13/2014 indicates the survey completion date for the classifications and rates under that identifier.

Survey wage rates are not updated and remain in effect until a new survey is conducted.

#### Union Average Rate Identifiers

Classification(s) listed under the UAVG identifier indicate that no single majority rate prevailed for those classifications; however, 100% of the data reported for the classifications was union data. EXAMPLE: UAVG-OH-0010 08/29/2014. UAVG indicates that the rate is a weighted union average rate. OH indicates the state. The next number, 0010 in the example, is an internal number used in producing the wage determination. 08/29/2014 indicates the survey completion date for the classifications and rates under that identifier.

A UAVG rate will be updated once a year, usually in January of each year, to reflect a weighted average of the current negotiated/CBA rate of the union locals from which the rate is

based.

-----  
WAGE DETERMINATION APPEALS PROCESS

1.) Has there been an initial decision in the matter? This can be:

- \* an existing published wage determination
- \* a survey underlying a wage determination
- \* a Wage and Hour Division letter setting forth a position on a wage determination matter
- \* a conformance (additional classification and rate) ruling

On survey related matters, initial contact, including requests for summaries of surveys, should be with the Wage and Hour Regional Office for the area in which the survey was conducted because those Regional Offices have responsibility for the Davis-Bacon survey program. If the response from this initial contact is not satisfactory, then the process described in 2.) and 3.) should be followed.

With regard to any other matter not yet ripe for the formal process described here, initial contact should be with the Branch of Construction Wage Determinations. Write to:

Branch of Construction Wage Determinations  
Wage and Hour Division  
U.S. Department of Labor  
200 Constitution Avenue, N.W.  
Washington, DC 20210

2.) If the answer to the question in 1.) is yes, then an interested party (those affected by the action) can request review and reconsideration from the Wage and Hour Administrator (See 29 CFR Part 1.8 and 29 CFR Part 7). Write to:

Wage and Hour Administrator  
U.S. Department of Labor  
200 Constitution Avenue, N.W.  
Washington, DC 20210

The request should be accompanied by a full statement of the interested party's position and by any information (wage payment data, project description, area practice material, etc.) that the requestor considers relevant to the issue.

3.) If the decision of the Administrator is not favorable, an interested party may appeal directly to the Administrative Review Board (formerly the Wage Appeals Board). Write to:

Administrative Review Board  
U.S. Department of Labor  
200 Constitution Avenue, N.W.  
Washington, DC 20210

4.) All decisions by the Administrative Review Board are final.

=====  
END OF GENERAL DECISION"

Fringe benefit amounts are applicable for all hours worked except when otherwise noted.

No laborer, workman or mechanic shall be paid at a rate less than that of a Journeyman except those classified as bona fide apprentices.

Apprentices or trainees shall be permitted to work as such subject to Administrative Regulations adopted by the Commissioner of Workplace Standards. Copies of these regulations will be furnished upon request from any interested person.

Before using apprentices on the job the contractor shall present to the Contracting Officer written evidence of registration of such employees in a program of a State apprenticeship and training agency approved and recognized by the U. S. Bureau of Apprenticeship and Training. In the absence of such a State agency, the contractor shall submit evidence of approval and registration by the U. S. Bureau of Apprenticeship and Training.

The contractor shall submit to the Contracting Officer, written evidence of the established apprenticeship-journeyman ratios and wage rates in the project area, which will be the basis for establishing such ratios and rates for the project under the applicable contract provisions.

**TO: EMPLOYERS/EMPLOYEES**

**PREVAILING WAGE SCHEDULE:**

**The wages indicated on this wage schedule are the least permitted to be paid for the occupations indicated. When an employee works in more than one classification, the employer must record the number of hours worked in each classification at the prescribed hourly base rate.**

**OVERTIME:**

**Overtime is to be paid to an employee at a rate not less than one and one-half times the basic rate of pay for all hours worked in excess of forty (40) hours in such workweek. Wage violations or questions should be directed to the designated Engineer or the undersigned.**

Director  
Division of Construction Procurement  
Frankfort, Kentucky 40622  
502-564-3500

**NOTICE OF REQUIREMENT FOR AFFIRMATIVE ACTION  
TO ENSURE EQUAL EMPLOYMENT OPPORTUNITY  
(Executive Order 11246)**

1. The Offeror's or Bidder's attention is called to the "Equal Opportunity Clause" and the "Standard Federal Equal Employment Specifications" set forth herein.
2. The goals and timetables for minority and female participation, expressed in percentage terms for the Contractor's aggregate work force in each trade on all construction work in the covered area, are as follows:

<b>GOALS FOR MINORITY PARTICIPATION IN EACH TRADE</b>	<b>GOALS FOR FEMALE PARTICIPATION IN EACH TRADE</b>
3.5%	6.9%

These goals are applicable to all the Contractor's construction work (whether or not it is Federal or federally-assisted) performed in the covered area. If the contractor performs construction work in a geographical area located outside of the covered area, it shall apply the goals established for such geographical area where the work is actually performed. With regard to this second area, the contractor also is subject to the goals for both its federally involved and non-federally involved construction.

The Contractor's compliance with the Executive Order and the regulations in CFR Part 60-4 shall be based on its implementation of the Equal Opportunity Clause, specific affirmative action obligations required by the specifications set forth in 41 CFR 60-4, 3(a), and its efforts to meet the goals. The hours of minority and female employment and training must be substantially uniform throughout the length of the contract, and in each trade, and the contractor shall make a good faith effort to employ minorities and women evenly on each of its projects. The transfer of minority or female employees or trainees from Contractor to Contractor or from project to project for the sole purpose of meeting the Contractor's goals shall be a violation of the contract, the Executive Order and the regulations in 41 CFR Part 60-4. Compliance with the goals will be measured against the total work hours performed.

3. The Contractor shall provide written notification to the Director of the Office of Federal Contract Compliance Programs within ten (10) working days of award of any construction subcontract in excess of \$10,000.00 at any tier for construction work under the contract resulting from this solicitation. The notification shall list the name, address and telephone number of the subcontractor; employer identification number of the subcontractor; estimated dollar amount of the subcontract; estimated starting and completion dates of the subcontract; and the geographical area in which the subcontract is to be performed. The notification shall be mailed to:

**Evelyn Teague, Regional Director  
Office of Federal Contract Compliance Programs  
61 Forsyth Street, SW, Suite 7B75  
Atlanta, Georgia 30303-8609**

4. As used in this Notice, and in the contract resulting from this solicitation, the "**covered area**" is Union County.

**PART IV**  
**INSURANCE**

Refer to  
*Kentucky Standard Specifications for Road and Bridge Construction,*  
current edition

**PART V**  
**BID ITEMS**

**PROPOSAL BID ITEMS**

Report Date 11/17/20

**Section: 0001 - ROADWAY**

LINE	BID CODE	ALT	DESCRIPTION	QUANTITY	UNIT	UNIT PRIC	FP	AMOUNT
0010	00001		DGA BASE	622.00	TON		\$	
0020	00020		TRAFFIC BOUND BASE	25.00	TON		\$	
0030	00100		ASPHALT SEAL AGGREGATE	5.00	TON		\$	
0040	00103		ASPHALT SEAL COAT	.60	TON		\$	
0050	00190		LEVELING & WEDGING PG64-22	935.00	TON		\$	
0060	00212		CL2 ASPH BASE 1.00D PG64-22	1,149.00	TON		\$	
0070	00301		CL2 ASPH SURF 0.38D PG64-22	4,838.00	TON		\$	
0090	00441		ENTRANCE PIPE-18 IN	77.00	LF		\$	
0100	00462		CULVERT PIPE-18 IN	12.00	LF		\$	
0110	00464		CULVERT PIPE-24 IN	13.00	LF		\$	
0120	01310		REMOVE PIPE	90.00	LF		\$	
0130	01987		DELINEATOR FOR GUARDRAIL BI DIRECTIONAL WHITE	16.00	EACH		\$	
0140	01987		DELINEATOR FOR GUARDRAIL BI DIRECTIONAL WHITE (LUCIOL SYSTEMS BIDIRECTIONAL LINEAR DELINEATION)	44.00	EACH		\$	
0150	02351		GUARDRAIL-STEEL W BEAM-S FACE	1,345.00	LF		\$	
0160	02360		GUARDRAIL TERMINAL SECTION NO 1	2.00	EACH		\$	
0170	02367		GUARDRAIL END TREATMENT TYPE 1	9.00	EACH		\$	
0180	02378		GUARDRAIL CONNECTOR TO BRIDGE END TY D	4.00	EACH		\$	
0190	02381		REMOVE GUARDRAIL	200.00	LF		\$	
0200	02396		REMOVE GUARDRAIL END TREATMENT	3.00	EACH		\$	
0210	02483		CHANNEL LINING CLASS II	630.00	TON		\$	
0220	02562		TEMPORARY SIGNS	603.00	SQFT		\$	
0230	02575		DITCHING AND SHOULDERING	31,259.00	LF		\$	
0240	02603		FABRIC-GEOTEXTILE CLASS 2	190.00	SQYD		\$	
0250	02607		FABRIC-GEOTEXTILE CLASS 2 FOR PIPE	52.00	SQYD	\$2.00	\$	\$104.00
0260	02625		REMOVE HEADWALL	1.00	EACH		\$	
0270	02650		MAINTAIN & CONTROL TRAFFIC (UNION KY 130 HSIP)	1.00	LS		\$	
0280	02671		PORTABLE CHANGEABLE MESSAGE SIGN	2.00	EACH		\$	
0290	02676		MOBILIZATION FOR MILL & TEXT (UNION KY 130 HSIP)	1.00	LS		\$	
0300	02677		ASPHALT PAVE MILLING & TEXTURING	339.00	TON		\$	
0310	02697		EDGE LINE RUMBLE STRIPS	60,705.00	LF		\$	
0320	02701		TEMP SILT FENCE	13,755.00	LF		\$	
0330	02703		SILT TRAP TYPE A	18.00	EACH		\$	
0340	02704		SILT TRAP TYPE B	18.00	EACH		\$	
0350	02705		SILT TRAP TYPE C	18.00	EACH		\$	
0360	02706		CLEAN SILT TRAP TYPE A	18.00	EACH		\$	
0370	02707		CLEAN SILT TRAP TYPE B	18.00	EACH		\$	
0380	02708		CLEAN SILT TRAP TYPE C	18.00	EACH		\$	
0390	02726		STAKING (UNION KY 130 HSIP)	1.00	LS		\$	
0400	03240		BASE FAILURE REPAIR	631.00	SQYD		\$	
0420	05950		EROSION CONTROL BLANKET	31,259.00	SQYD		\$	
0430	05952		TEMP MULCH	57,760.00	SQYD		\$	

**PROPOSAL BID ITEMS**

Report Date 11/17/20

LINE	BID CODE	ALT	DESCRIPTION	QUANTITY	UNIT	UNIT PRIC	FP	AMOUNT
0440	05953		TEMP SEEDING AND PROTECTION	43,320.00	SQYD		\$	
0450	05963		INITIAL FERTILIZER	.50	TON		\$	
0460	05964		MAINTENANCE FERTILIZER	.30	TON		\$	
0470	05985		SEEDING AND PROTECTION	52,251.00	SQYD		\$	
0480	05990		SODDING	3,126.00	SQYD		\$	
0490	06406		SBM ALUM SHEET SIGNS .080 IN	446.63	SQFT		\$	
0500	06407		SBM ALUM SHEET SIGNS .125 IN	77.84	SQFT		\$	
0510	06410		STEEL POST TYPE 1	978.00	LF		\$	
0520	06510		PAVE STRIPING-TEMP PAINT-4 IN	13,376.00	LF		\$	
0530	06542		PAVE STRIPING-THERMO-6 IN W	60,705.00	LF		\$	
0540	06543		PAVE STRIPING-THERMO-6 IN Y	32,065.00	LF		\$	
0550	06556		PAVE STRIPING-DUR TY 1-6 IN W	230.00	LF		\$	
0560	06557		PAVE STRIPING-DUR TY 1-6 IN Y	230.00	LF		\$	
0570	08100		CONCRETE-CLASS A	6.39	CUYD		\$	
0575	10020NS		FUEL ADJUSTMENT (ADDED: 11-10-20)	10,933.00	DOLL	\$1.00	\$	\$10,933.00
0577	10030NS		ASPHALT ADJUSTMENT (ADDED: 11-10-20)	27,461.00	DOLL	\$1.00	\$	\$27,461.00
0580	20748ED		SHOULDER MILLING/TRENCHING	5,222.00	SQYD		\$	
0590	21373ND		REMOVE SIGN	73.00	EACH		\$	
0595	23362ES403		CL2 ASPH SURF 0.5B PG64-22 (ADDED: 11-17-20)	154.00	TON		\$	
0600	24575ES610		HEADWALL (18 INCH TRIPLE PIPE CULVERT)	1.00	EACH		\$	
0610	24575ES610		HEADWALL (24 INCH STANDARD CONCRETE)	1.00	EACH		\$	
0620	24575ES610		HEADWALL (SLOPED & MITERED CONCRETE-FOR 24 INCH PIPE)	1.00	EACH		\$	
0630	24575ES610		HEADWALL (SLOPED & MITERED CONCRETE-FOR 36 INCH PIPE)	1.00	EACH		\$	
0640	24631EC		BARCODE SIGN INVENTORY	133.00	EACH		\$	
0650	24970EC		ASPHALT MATERIAL FOR TACK NON- TRACKING	25.20	TON		\$	

**Section: 0002 - DEMOBILIZATION**

LINE	BID CODE	ALT	DESCRIPTION	QUANTITY	UNIT	UNIT PRIC	FP	AMOUNT
0660	02569		DEMOBILIZATION	1.00	LS		\$	